

Multimedia
Enhanced

KitchenAid®



TECHNICAL MANUAL

**KitchenAid® and Maytag®
24" Microfiltration Dishwashers**

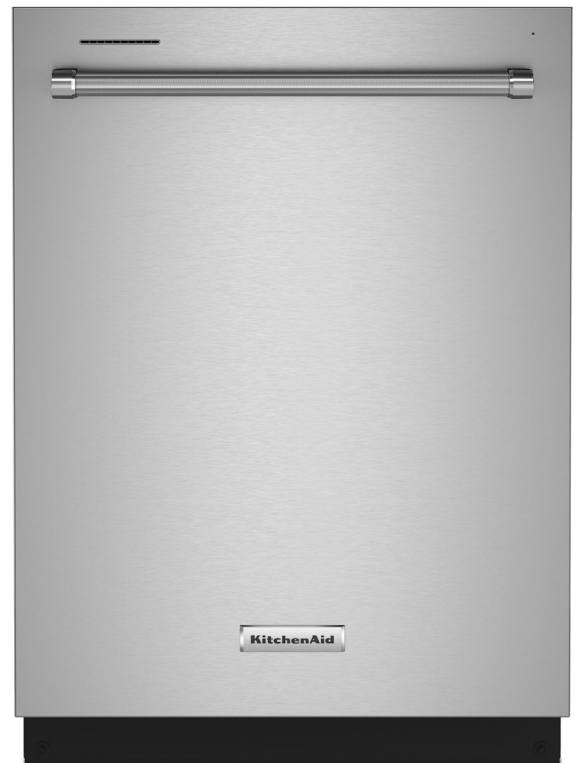
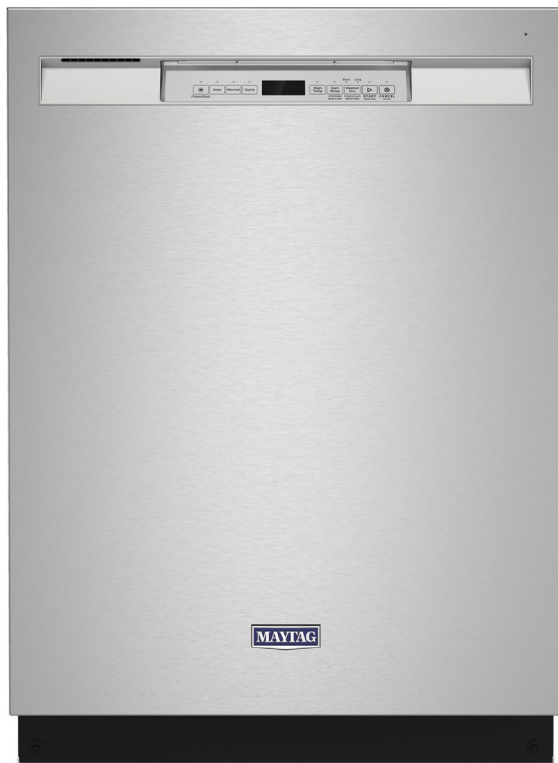

W11499711 Rev B

FOREWORD

This Technical Manual (Part No. W11499711 Rev B), provides the In-Home Service Professional with service information for the “KitchenAid® and Maytag® 24" Microfiltration Dishwashers” For specific operating information on the model being serviced, refer to the “Owner's Manual” and “Quick Start Guide” provided with the dishwasher.

The Wiring Diagram used in this Technical Manual is typical and should be used for training purposes only. Always use the Wiring Diagram supplied with the product when servicing the dishwasher.

For specific operating and installation information on the model being serviced, refer to the literature provided with the dishwasher.

GOALS AND OBJECTIVES

This Technical Manual provides information that will enable the In-Home Service Professional to properly diagnose malfunctions and repair the “KitchenAid® and Maytag® 24" Microfiltration Dishwashers.”

The objectives of this Technical Manual are to:

- Understand and follow proper safety precautions.
- Successfully troubleshoot and diagnose malfunctions.
- Successfully perform necessary repairs.
- Successfully return the dishwasher to its proper operational status.

WHIRLPOOL CORPORATION assumes no responsibility for any repairs made on our products by anyone other than authorized In-Home Service Professionals.

©2023 Whirlpool Corporation. Benton Harbor, MI 49022

TABLE OF CONTENTS

KitchenAid® and Maytag® 24" Microfiltration Dishwashers

SECTION 1: GENERAL INFORMATION	1-01
DISHWASHER SAFETY	1-02
GENERAL THEORY OF OPERATION	1-03
NEW COMPONENTS/FEATURES	1-04
MODEL NUMBER AND SERIAL NUMBER LABEL LOCATION	1-05
TECH SHEET LOCATION	1-05
MODEL NUMBER NOMENCLATURE	1-06
PRODUCT SPECIFICATIONS.....	1-08
PRODUCT FEATURES.....	1-11
SECTION 2: DIAGNOSTICS AND TROUBLESHOOTING	2-01
SAFETY	2-02
SERVICE DIAGNOSTICS CYCLE TIMING.....	2-03
ACTIVATING SERVICE DIAGNOSTICS MODE.....	2-03
SERVICE DIAGNOSTICS CYCLE NOTES	2-03
SERVICE DIAGNOSTICS MODE MENU TABLE	2-03
SERVICE ERROR CODES.....	2-04
TROUBLESHOOTING GUIDE.....	2-12
SECTION 3: COMPONENT TESTING	3-01
SAFETY	3-02
SERVICE TOOL CONNECTION LOCATION.....	3-03
CONTROL BOARD INFORMATION	3-04
COMPONENT TESTING	3-04
COMPONENT LOCATION	3-20
SECTION 4: COMPONENT ACCESS	4-01
INSULATION BLANKET AND DOOR LATCH STRIKE	4-02
SIPHON BREAK.....	4-03
ACCESSING DOOR COMPONENTS.....	4-04
REMOVING THE INNER DOOR AND HINGES	4-06
PRODRY™ ASSEMBLY	4-07
REMOVING USER INTERFACE AND DOOR LATCH.....	4-08
REMOVING DISPENSER ASSEMBLY	4-09
REMOVING THE UPPER RACK (FOR SATIN GLIDE RAILS)	4-10
REMOVING THE THIRD LEVEL RACK (AVAILABLE ON SOME MODELS)	4-12
REMOVING LOWER SPRAY ARM AND MANIFOLD ASSEMBLY.....	4-14
UNDER TUB COMPONENTS	4-15
REMOVING HEATER ASSEMBLY.....	4-16
REMOVING DRAIN PUMP.....	4-16
DRIP PAN AND FLOAT ASSEMBLY	4-18
REMOVING DRAIN PUMP AND MOTOR ASSEMBLY	4-19

Notes

Section 1: General Information

This section provides general safety, parts, and information for the “KitchenAid® and Maytag® 24” Microfiltration Dishwashers.”

- Dishwasher Safety
- General Theory of Operation
- New Components/Features
- Model Number and Serial Number Label location
- Tech Sheet Location
- Model Number Nomenclature
- Product Specifications
- Product Features
 - KitchenAid® Cycle Guide
 - Maytag® Cycle Guide

Dishwasher Safety

Your safety and the safety of others are very important.

We have provided many important safety messages in this manual and on your appliance. Always read and obey all safety messages.



This is the safety alert symbol.

This symbol alerts you to potential hazards that can kill or hurt you and others.

All safety messages will follow the safety alert symbol and either the word “DANGER” or “WARNING.”

These words mean:

⚠ DANGER

You can be killed or seriously injured if you don't immediately follow instructions.

⚠ WARNING

You can be killed or seriously injured if you don't follow instructions.

All safety messages will tell you what the potential hazard is, tell you how to reduce the chance of injury, and tell you what can happen if the instructions are not followed.

IMPORTANT SAFETY INSTRUCTIONS

WARNING: When using the dishwasher, follow basic precautions, including the following:

- Read all instructions before using the dishwasher.
- Use the dishwasher only for its intended function.
- Use only detergents or rinse agents recommended for use in a dishwasher, and keep them out of the reach of children.
- When loading items to be washed:
 - 1) Locate sharp items so that they are not likely to damage the door seal; and
 - 2) Load sharp knives with the handles up to reduce the risk of cut-type injuries.
- Do not wash plastic items unless they are marked “dishwasher safe” or the equivalent. For plastic items not so marked, check the manufacturer's recommendations.
- Do not touch the heating element during or immediately after use.
- Do not operate the dishwasher unless all enclosure panels are properly in place.
- Do not tamper with controls.
- Do not abuse, sit on, or stand on the door, lid, or dish racks of the dishwasher.
- Do not use replacement parts that have not been recommended by the manufacturer (e.g. parts made at home using a 3D printer).
- To reduce the risk of injury, do not allow children to play in or on the dishwasher.
- Under certain conditions, hydrogen gas may be produced in a hot water system that has not been used for two weeks or more. **HYDROGEN GAS IS EXPLOSIVE.** If the hot water system has not been used for such a period, before using the dishwasher turn on all hot water faucets and let the water flow from each for several minutes. This will release any accumulated hydrogen gas. As the gas is flammable, do not smoke or use an open flame during this time.
- Remove the door or lid to the washing compartment when removing an old dishwasher from service or discarding it.

SAVE THESE INSTRUCTIONS

General Theory of Operation

KitchenAid® Microfiltration Wash System

No Filter Cup, No Chopper

The industry's first microfiltration system is a clear departure from traditional, passive filtration because it continuously filters 100% of the water, reducing the cycle time and energy consumption on the heaviest loads.

Similar on the Surface, Radically Different Inside

The only visible filtration component of the new filtration system is the coarse filter in the bottom of the tub. The rest of the high-performance filtration system is below the tub.

How Microfiltration Works

1. Water and food particles flow through the coarse filter into the filter housing.



2. An impeller pulls wash and rinse water into the spinning ultra-fine filter.

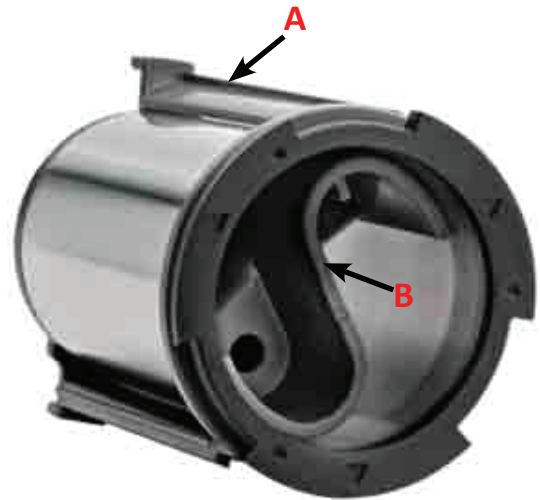

A. Outer blades
B. Inner Blades

3. The ultra-fine filter is cleaned by an area of back-pressure created by two sets of wing-shaped blades located inside and outside the filter.
4. Food particles remain suspended inside the filter housing; filtered water is pumped back to the wash arms.
5. During draining, a secondary pump flushes out food particles and soils.

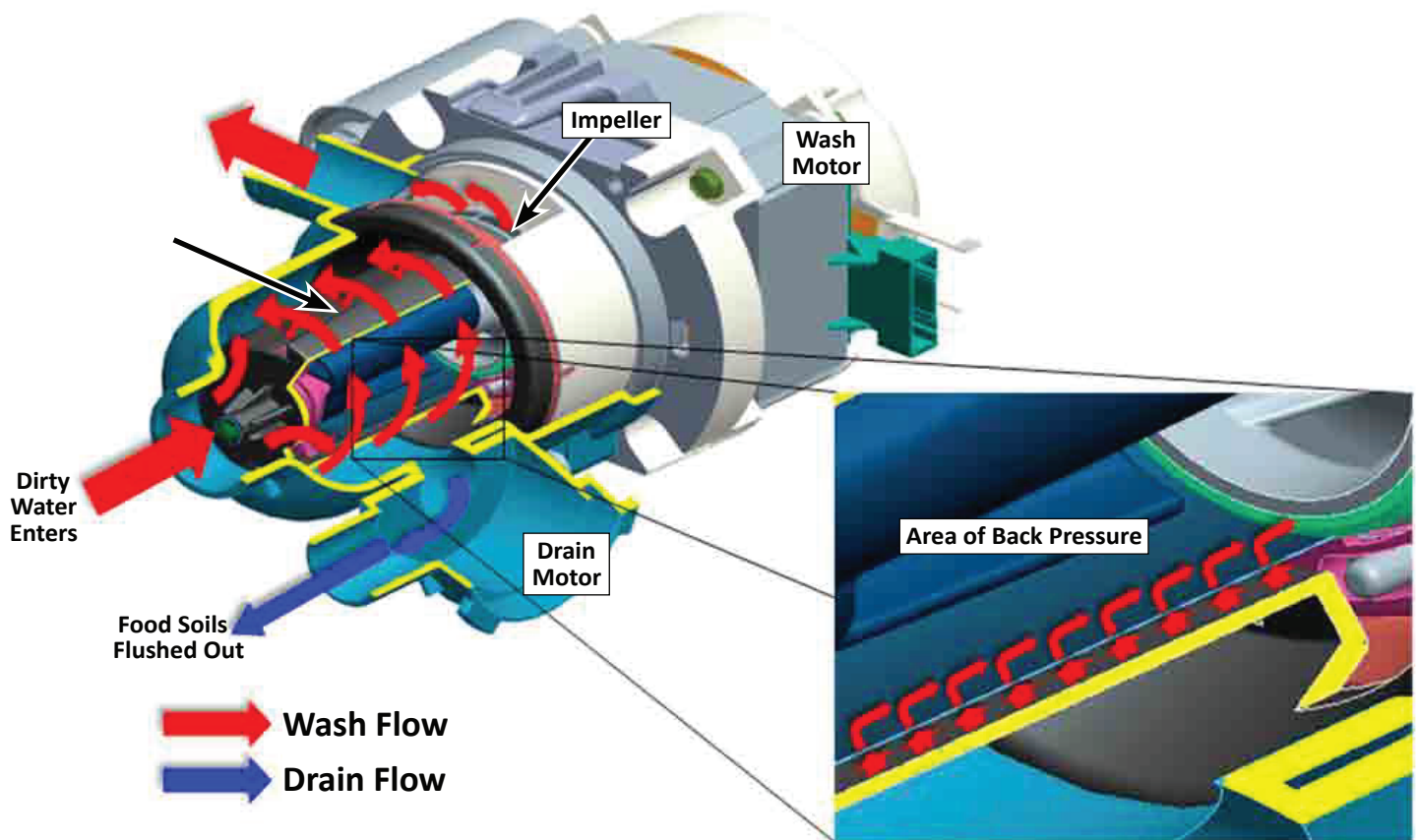

New Components/Features

- Tub - Taller tub for the largest place setting on the market. Less room underneath the unit to access components for service.
- TLR - Third level rack option with it's own wash system.
- Rear feed tube with four wash zones.
- Spray Arms - It has new attachment method and comes with compressed size.
- Four Legs - Made of plastic similar to dryer legs.
- Improved anchoring - Four anchor locations in top tub collar to top mount the dishwasher under the counter-top.
- New small screw head on anchor screws to fit into smaller side anchor holes in side of tub collar.
- Diverter motor - The function of leak detection alerts the customer to call service.
- New installation/service cycle can be activated after the installation to test the leaks for approximately 5 minutes.
- H₂O error code alarm activates if the installer forgets to turn on the water valve.
- Improved diagnostics - Diagnose with more faults/error codes, some will be displayed to customers.
- Flood/Water leak detection - Drip tray and float are present to catch leaks from under the tub lip or corners. Leak detection shuts unit off and turns on drain pump and alerts the customer to call service.
- Flow meter - It measures fill against time.
- Tub LED's - Bar LED's incorporated into Third Level Rack support.
- Terminal box - New terminal box comes with screws. No wire nuts are present in terminal box.

Model Number and Serial Number Label Location

Model Number and
Serial Number Label Location

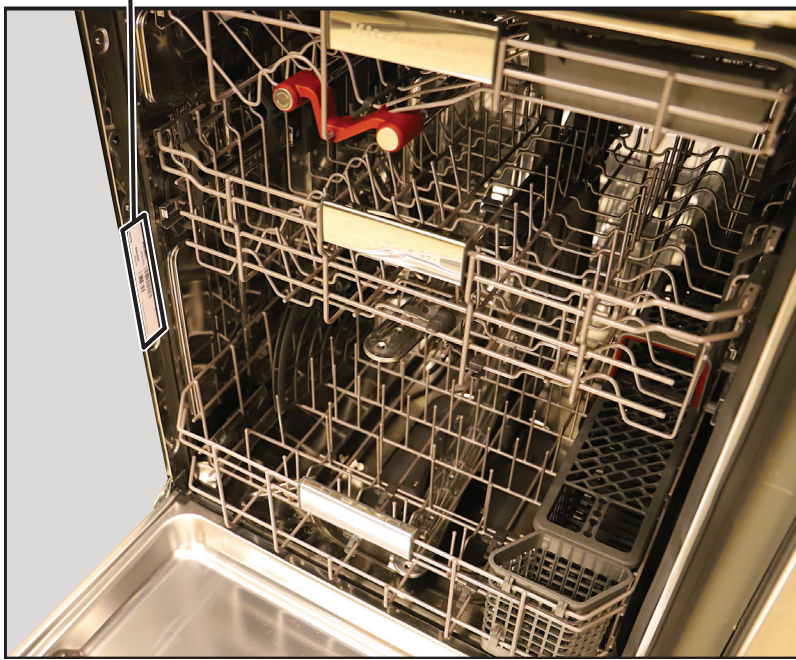

Tech Sheet Location

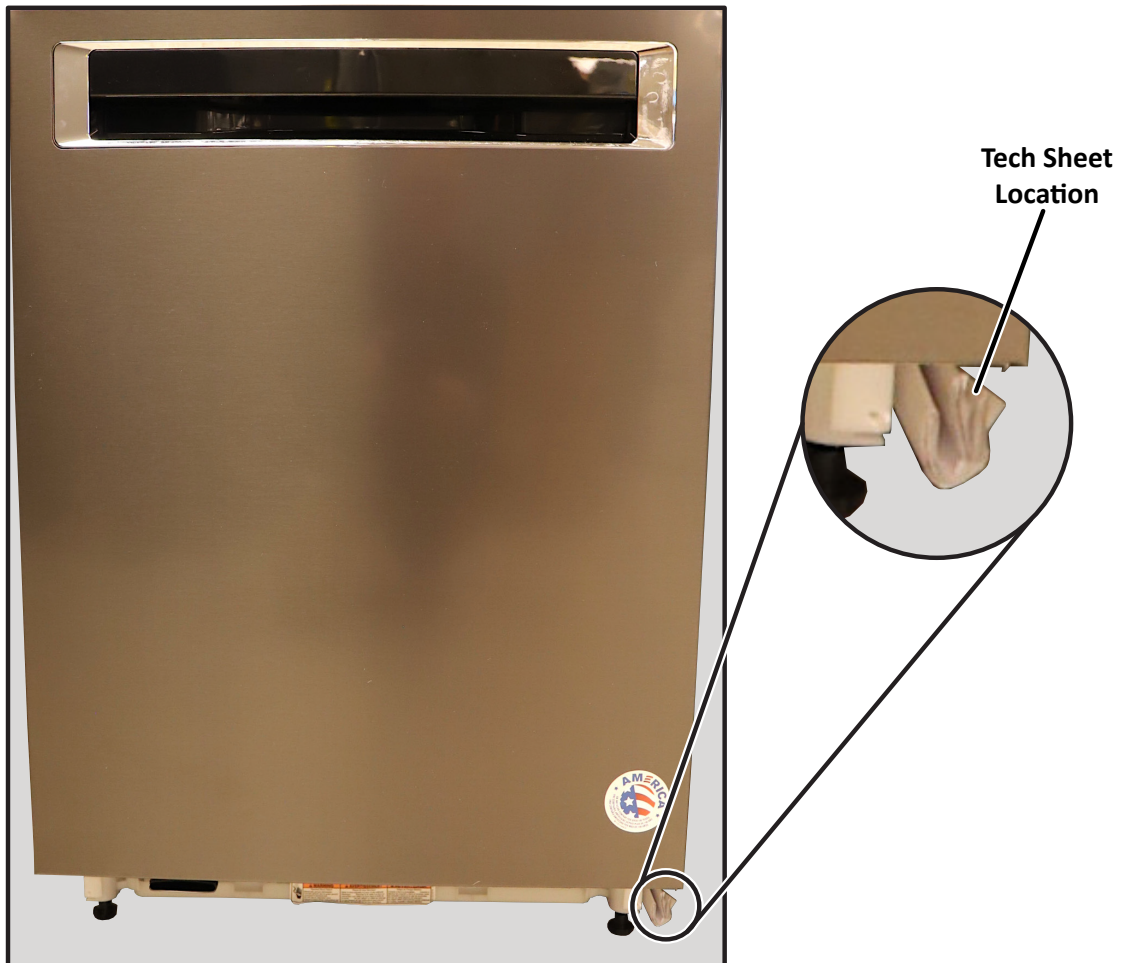

Model Number Nomenclature

KitchenAid® Model Nomenclature

MODEL NUMBER INTERNATIONAL SALES OR MARKETING CHANNEL	K	D	F	M	40	4	K	BS
Brand K = KitchenAid®								
Categories D = Dishwasher								
Configuration/Fuel F = Front Control P = Pocket Handle T = Top Control								
Product Detail M = 2015 System								
Feature Pack 40 - 60 = ProScrub™ ≥70 = ProDry™								
Width 4 = 24 inches								
Year Model Introduced K = 2020 L = 2021								
Color BS= Black Stainless PS = Gray Stainless PA = Panel-Ready								

Model Number Nomenclature (Continued)

Maytag® Model Nomenclature

MODEL NUMBER INTERNATIONAL SALES OR MARKETING CHANNEL	M	D	B	79	59	S	K	Z
Brand M = Maytag®								
Categories D = Dishwasher								
Product Type B = Built-In								
Feature Package 46 - 89								
Console 09 - 49 = Classic 50 - 99 = FID								
Tub Material S = 100% Stainless Steel								
Year Model Introduced K = 2020 L = 2021								
Color B = Black W = White K = Cast Iron Black Z = Fingerprint Resistant Stainless Steel								

Product Specifications

KitchenAid® 44 dBA Dishwasher with FreeFlex™ Third Rack

Maytag® Top Control Dishwasher with/without Third Level Rack and Dual Power filtration

Dimensions	
Depth Closed Excluding Handles (IN, inches)	24 ¹ / ₂
Depth Closed Including Handles (IN, inches)	24 ¹ / ₂ or 26 ³ / ₄
Depth With Door Open 90 Degree (IN, inches)	51
Depth (IN, inches)	24 ¹ / ₂ or 26 ³ / ₄
Height (IN, inches)	31 ¹ / ₂ or 33 ¹ / ₂
Width (IN, inches)	23 ⁷ / ₈
Number of Place Settings (KitchenAid® Models Only)	16
Number of Place Settings (Maytag® Models Only)	14 or 15
Description	
Dishwasher Type	Built-In
Controls	
Automatic Temperature Controls	Yes
Control Location	Front or Hidden Top
Control Type	Tap Touch with Display or Electronic Touch with Display
End of Cycle Signal	Yes
Sensor	Yes
Status Light	White
Exterior	
Control Panel Color	Black or White or Gray
Door Style	Flat
Handle Color	Gray or White or Black or Stainless Steel
Handle Material	Plastic or Metal
Handle Type	Long Pocket or Towel Bar or Short Pocket
Magnetic Door	Yes
Toe Panel Color	Black or White
True Hold Door	Yes
Features	
Decibel Level (dBA) (KitchenAid® Models Only)	44
Decibel Level (dBA) (Maytag® Models Only)	44 or 47 or 50
Dispensers	Detergent and Rinse Aid
Number of Wash Levels (KitchenAid® Models Only)	7
Number of Wash Levels (Maytag® Models Only)	5 or 6
Rinse Aid Dispenser Level Indicator	Yes
Sound Package	Yes
Cycles and Options (KitchenAid® Models Only)	
Dishwasher Cycle Selections	Express Wash, Normal, ProWash™, Rinse, Tough
Cycles and Options (Maytag® Models Only)	
Dishwasher Cycle Selections	Auto, Normal, Quick, PowerBlast, Rinse

Product Specifications (Continued)

Cycles		
Number of Wash Cycles	5	
Options	KitchenAid® Models Only	Maytag® Models Only
Dishwasher Option Selections	Top 2 Racks Extended ProDry™ or Extended Heat Dry 4 Hour Delay or 1-24 Hour Delay or 2-4-8 Hour Delay Heated Dry or ProDry™ Hi Temp Wash Sani Rinse	4 Hour Delay Control Lock High Temp Long Heated Dry Sani Rinse Short Heated Dry
Details	KitchenAid® Models Only	Maytag® Models Only
Drying System Type	Vent Dry or Fan Dry with Heating Element	Vent Dry or Fan Dry with Heating Element
Leak Detect	Yes (For KDTM704LPA model only)	Yes (For MDB4949SKZ, MDB4949SKB and MDB4949SKW models only)
Number of Racks	3	2 or 3
Number of Wash Arms	5	3 or 4
Rack Material	Nylon	Nylon
Tub Material	Stainless Steel	Stainless Steel
Tub Style	Built-in Tall Tub 24"	Built-in Tall Tub 24"
Wash System	Clean Water Wash	Dual Power Filtration
Wash System Type	MicroFilter	Microfilter with chopper
Water Filtration	Yes	Yes
Hoses Included	Drain Hose	Drain Hose
Interior Light	Yes	NA
2nd Level Rack		
Adjustable	2 Position Removable	
Cushion-Tip Tines	Yes	
Extras (KitchenAid® Models Only)	2 or 4 or 6 Stemware Holders Stainless Steel Wash Arm	
Extras (Maytag® Models Only)	Stainless Steel Wash Arm Plastic Cup Shelf	
Fold-Down Tines (KitchenAid® Models Only)	1 Row 6 Position	
Fold-Down Tines (Maytag® Models Only)	No	
Glides	Wheels or Ball Bearings	
Style	Extended	
Lower Rack		
Cushion-Tip Tines	Yes	
Extras	1 Cup Shelf (for MDB4949SKZ0, MDB4949SKB0 and MDB4949SKW0 models only) Stainless Steel Wash Arm Sliding Tines (KitchenAid® Models Only) Knife Holder (for KDTM804KPS0 and KDPM804KBS0 models only)	
Fold-Down Tines (KitchenAid® Models Only)	1 Adjustable 1 Fold Down	
Fold-Down Tines (Maytag® Models Only)	No	
Glides	Wheels or Ball Bearings	
Style	Extended	
Utility Basket (KitchenAid® Models Only)	Yes	

Product Specifications (Continued)

Silverware Basket	
Type	Large In the Rack Basket or Stainless Steel Basket
Location	Bottom Rack
Covers	Yes
Culinary Basket (KitchenAid® Models Only)	Yes
Third Level Rack (KitchenAid® Models Only)	
Glides	SatinGlide Rails or SatinGlide Max Rails
Removable	Yes
Type	Third rack with dual rotating wash tubes
Third Level Rack (Maytag® Models Only)	
Glides	Ball Bearings
Removable	Yes
Type	Third rack with wash tube
Certifications	
CEE Tier	Tier I
CUL	Yes
Energy Rating (kWh/year)	270
Energy Star® Qualified	ENERGY STAR® Qualified
Kosher Consumer Friendly	Yes
NSF® Certified	Yes
UL	Yes
Prop 65	Standard
Electrical	
Amps	15
Hz	60
Volts	120

Product Features

KitchenAid® Cycle Guide

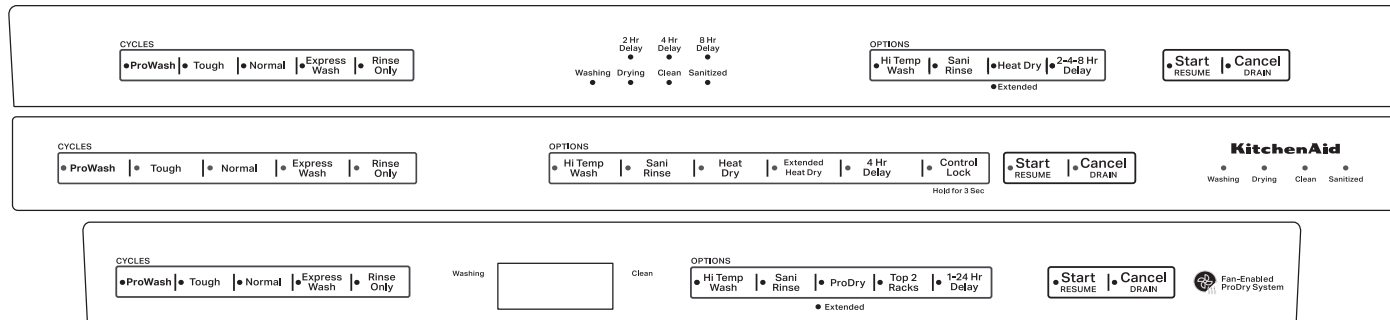

CYCLE

Control	Purpose
ProWash	Senses soil to automatically optimize cycle. ProWash™ cycle is selected if START is pressed first.
Tough	Use for hard to clean items.
Normal	This cycle is recommended for daily, regular or typical use to completely wash and dry a full load of normally soiled dishes. This dishwasher’s government energy certifications were based on the Normal cycle with only the Heated Dry option selected.
Light	Use for lightly soiled items like china and crystal.
Express Wash	Use when you need faster results.
Rinse Only	Use for rinsing dishes, glasses, and silverware that will not be washed right away. Do not use detergent.

OPTIONS

Control	Purpose
Hi Temp Wash	Helps remove tough, baked on food.
Sani Rinse	Sanitizes dishes and glassware in accordance with NSF International NSF/ANSI Standard 184 for Residential Dishwashers. See this section in the Owner’s Manual.
Heated Dry	Dries dishes with heat. Load plastic item in upper racks.
Extended	Increases the energy used for drying the dishes. This may lengthen the cycle time.
ProDry	Dries dishes with heat and a fan. Use for best performance.
Top 2 Racks	Wash items in the top two racks only. Only a limited amount of water will be sent to the lower spray arm.
Delay	Runs the dishwasher at a later time.
Start / Resume	Push to start or resume a cycle.
Cancel / Drain	Push to reset any cycle or options during selection. Push to end a cycle once started.

Product Features (Continued)

Maytag® Cycle Guide

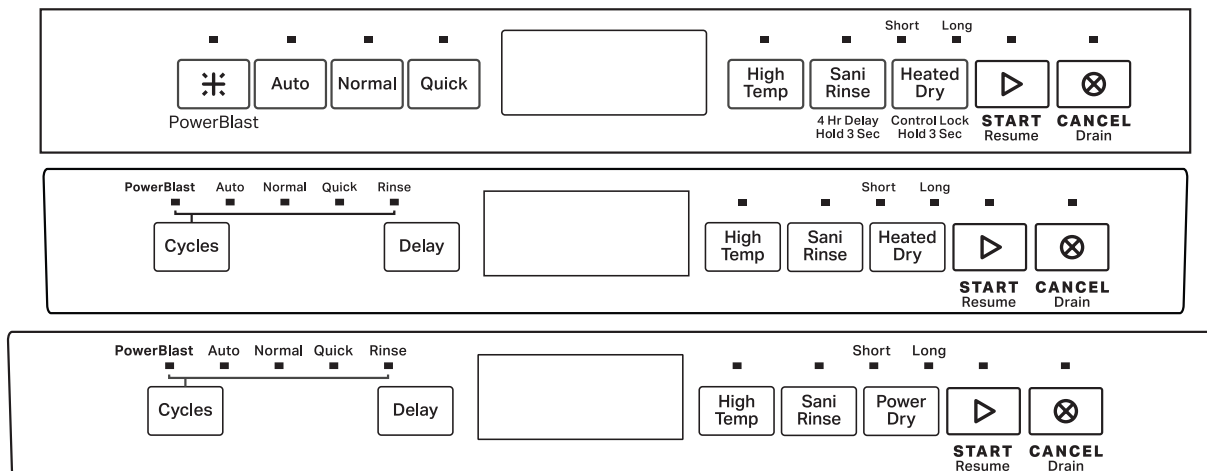

CYCLE

Control	Purpose
Auto	Senses soil to automatically optimize cycle. Auto cycle is selected if START is pressed first.
PowerBlast	Use for hard to clean items.
Normal	This cycle is recommended for daily, regular or typical use to completely wash and dry a full load of normally soiled dishes. This dishwasher's government energy certifications were based on the Normal cycle with only the Heated Dry option selected.
Quick	Use when you need faster results.
Rinse	Use for rinsing dishes, glasses, and silverware that will not be washed right away. Do not use detergent.

OPTIONS

Control	Purpose
High Temp	Helps remove tough, baked on food.
Sani Rinse	Sanitizes dishes and glassware in accordance with NSF International NSF/ANSI Standard 184 for Residential Dishwashers. See this section in the Owner's Manual.
Heated Dry Short (Some Models) Power Dry Short	Dries dishes with heat. Load plastic item in upper racks. Dries dishes with heat and a fan. Load plastic item in upper racks.
Heated Dry Long (Some Models) Power Dry Long	Increases the Energy used for drying the dishes. This may lengthen the cycle time.
Delay	Runs the dishwasher at a later time.
Start / Resume	Push to start or resume a cycle.
Cancel / Drain	Push to reset any cycle or options during selection. Push to end a cycle once started.
Control Lock (on some models)	Use the Control Lock option to avoid unintended use of dishwasher between cycles, or cycle and option changes during a cycle. To turn ON/OFF, hold button for 3 seconds.

A blue, starburst-shaped badge with a white border and a drop shadow. The text "Multimedia Enhanced" is written in white, bold, sans-serif font, centered within the badge.

**Multimedia
Enhanced**

Section 2: Diagnostics and Troubleshooting

This section provides diagnostic, fault codes, and troubleshooting information for the “KitchenAid® and Maytag® 24” Microfiltration Dishwashers.”

- Safety
- Service Diagnostics Cycle Timing
- Activating Service Diagnostics Mode
- Service Diagnostics Cycle Notes
- Service Diagnostics Mode Menu Table
- Service Error Codes
- Troubleshooting Guide

Video Available  Look for this ICON through out Section 2.

For Service Technician Use Only

Safety

⚠ DANGER

<p>Electrical Shock Hazard</p> <p>Only authorized technicians should perform diagnostic voltage measurements.</p> <p>After performing voltage measurements, disconnect power before servicing.</p> <p>Failure to follow these instructions can result in death or electrical shock.</p>

⚠ WARNING

<p>Electrical Shock Hazard</p> <p>Disconnect power before servicing.</p> <p>Replace all parts and panels before operating.</p> <p>Failure to do so can result in death or electrical shock.</p>

Voltage Measurement Safety Information
<p>When performing live voltage measurements, you must do the following:</p> <ul style="list-style-type: none">■ Verify the controls are in the off position so that the appliance does not start when energized.■ Allow enough space to perform the voltage measurements without obstructions.■ Keep other people a safe distance away from the appliance to prevent potential injury.■ Always use the proper testing equipment.■ After voltage measurements, always disconnect power before servicing.

<p>IMPORTANT: Electrostatic Discharge (ESD) Sensitive Electronics</p> <p>ESD problems are present everywhere. ESD may damage or weaken the electronic control assembly. The new control assembly may appear to work well after repair is finished, but failure may occur at a later date due to ESD stress.</p> <ul style="list-style-type: none">■ Use an antistatic wrist strap. Connect wrist strap to green ground connection point or unpainted metal in the appliance <p style="text-align: center;">-OR-</p> <p>Touch your finger repeatedly to a green ground connection point or unpainted metal in the appliance.</p> <ul style="list-style-type: none">■ Before removing the part from its package, touch the antistatic bag to a green ground connection point or unpainted metal in the appliance.■ Avoid touching electronic parts or terminal contacts; handle electronic control assembly by edges only.■ When repackaging failed electronic control assembly in antistatic bag, observe above instructions.

<p>IMPORTANT SAFETY NOTICE — “For Technicians only”</p> <p>This service data sheet is intended for use by persons having electrical, electronic, and mechanical experience and knowledge at a level generally considered acceptable in the appliance repair trade. Any attempt to repair a major appliance may result in personal injury and property damage. The manufacturer or seller cannot be responsible, nor assume any liability for injury or damage of any kind arising from the use of this data sheet.</p>

For Service Technician Use Only

Service Diagnostics Cycle Timing

Numeric Display	All LEDs on	1				2				3	4	5 (Some models) 3	6	7			
Interval Time	0:01	0:02	Typical: 0:30 Max: 5:00	0:01	Typical: 1:00 Max: 2:09	0:18	Typical: 0:15 Max: 0:24	Typical: 0:20 Max: 0:44	0:01	0:20	0:20	0:20	0:30	0:15	Typical: 30 Max: 4:45	0:15	0:01
Service Test Steps	Pause	Vent opens	Drain pump1	Pause	Fill valve 1st fill 2.5 Liter ²	Wash motor	Fill valve fill 0.5 Liters ²	Fill valve fill 0.8 Liters wash start ²	Pause	Wash continues +dispenser activates+ Middle spray arm in motion	Wash continues+ Fan activates+ Ceiling spray arm in motion	Only TLR models - Ohio or Michigan rack is in motion activated ³	Wash continues +Heater turns on +Lower spray arm in motion	Wash continues +Drain pump	Drain Pump1	Drain	Pause
Typical Total Time																4:59	

NOTES:

1. Time varies depending on drain sensing.
2. Time varies depending on fill rate sensed by flow meter.
3. This interval is only included on models with a wash arm in the third level rack.
4. Cycle times out after 5 minutes.

Components and circuits in the test steps:

- Vent - Visual Observation
- Drain pump - Drain motor
- Fill valve - Fill
- Wash motor - Motor
- Dispenser - Dispenser
- Fan - DC Fan Motor
- Heater - Water heating/Heat dry

Diverter Motor and Position Optical Sensor

- Middle spray arm
- Ceiling spray arm
- Third level rack (Only TLR Models)
- Lower spray arm

NOTE: Refer to [Component Testing](#) for testing.

Use clear door for observations:

Kit number: W11179175

Activating Service Diagnostics Mode

To invoke the Service Diagnostics Mode, perform the following while in standby:

- Press any 3 keys (except Delay, Start or Cancel) in the sequence 1-2-3, 1-2-3, 1-2-3 with no more than 1 second between key presses. All LED's will illuminate if successful. Then press button #2 and shut door to start the service cycle.
- The Service Diagnostics Cycle will start when the door is closed.
- Invoking Service Diagnostics clears all status and last run information from memory and restores defaults. It also forces the next cycle to be a sensor calibration cycle.
 - Sensor calibration cycle may add an extra rinse (to assure clear water) before the final rinse. This cycle may be longer than a typical run.
- All LEDs turn on immediately upon receiving entry sequence (even if door is open) as a display test. A tone may play depending on the model.

Press Key #1: User Interface Test

- All LEDs remain on. Tone is played for each key pressed.

Press Key #2: Run Service Test Cycle

- To rapid advance 1 step at a time, press the Start/Resume key. Rapid advance may skip some sensor checks and prevent fault detection from working properly. Rapid advance can also cause false error codes to be detected in some cases.

NOTE: The diagnostics cycle will pause when the door is opened and resume when closed. No Start/Resume key press required to resume.

Press Key #3: Error Code History Display

- Up to 5 unique codes are saved in the history.
- Most recently detected error code is displayed first.
- If no faults are present, numeric display will show “-:--” or Clean LED will be off (Depending on display type).
- Press third key to advance to next error code stored. Three tones are played when the end of the error code history has been reached.

Press and Hold Key #3: Clear Fault History

- Tone will play when faults are cleared Exit procedure.
- The service diagnostics mode will timeout after 5 minutes of user inactivity.
- Press Cancel key to exit service diagnostics mode.
- Service diagnostics mode will be canceled if AC power is removed from the appliance.

Service Diagnostics Cycle Notes

1. Drain may be sensed or timed. Sensed drain maximum time is approximately 5 minutes, which includes retries. Sensed drain will have both wash motor and drain motor powered simultaneously. Timed drain is drain motor only.
2. Fills are measured by flow meter and time may vary according to water flow rate. If flow meter has failed, control will revert to timed fills and record fault code to history. Wash motor may turn on during fill process to verify the presence of water in the machine.
3. This step is only included on models that have a wash zone in the third level rack. On models without a third level wash zone or two racks, this step is skipped.

Reading Fault Code Display

Point LED Models

- Each fault code is displayed by blinking the Clean or Complete LED in a pattern to indicate the Function code and the Error code
- Fault display is a 4 step process. Count LED blinks for each portion of the code.
 1. Blink Clean or Complete LED Function code number of times
 2. Pause 2 seconds
 3. Blink Clean or Complete LED Error code number of times
 4. Pause 5 seconds.
- Each fault code is repeated until key #3 is pressed to advance to the next code or until the service mode is exited.

Numeric Display Models

- Each fault code is shown in the numeric display by first showing the Function code “F#” then the Error code “E#.”
- Fault display is a 4 step process:
 1. Display F#
 2. Pause 0.5 seconds
 3. Display E#
 4. Pause 1 second.
- Each fault code is repeated until key #3 is pressed to advance to the next code or until the service mode is exited.

Service Diagnostics Mode Menu Table

Types of Button Press	1st Button	2nd Button	3rd Button
Momentary Press	Activates User Interface Test	Activates Service Test Cycle	Displays Next Error Code
Hold for 5 seconds			Clears Error Code History

For Service Technician Use Only
Service Error Codes

⚠ DANGER	
	
Electrical Shock Hazard	
Only authorized technicians should perform diagnostic voltage measurements.	
After performing voltage measurements, disconnect power before servicing.	
Failure to follow these instructions can result in death or electrical shock.	

Fault codes are intended to give direction as to which component or subsystem has a failure. Service technician should troubleshoot the issue and confirm the validity of all fault codes before replacing parts.



NOTE: *These fault codes have advanced sensing abilities that provide a high confidence diagnosis. Embedded in the ACU circuit is voltage supply checking and current checking for selected loads. They are developed to provide more accurate detection and scope the particular component failure.

FUNCTION CODE	ERROR CODE	CAUSES	WHAT TO CHECK
1 - Control	1 - ACU	Relay or triac failure on main control board.	Unplug dishwasher or disconnect power and replace control.
	2 - MCU	Failure of Motor control on control board.	Unplug dishwasher or disconnect power and replace control.
2 - User Interface	1 - Stuck Key	Control detected stuck keys in user interface. NOTES: <ul style="list-style-type: none"> - If any keys are stuck, the stuck key(s) will be ignored and an error recorded to service history, but no alert to customer. - This fault is monitored on models with key switches only, not on capacitive touch key models. 	Check responsiveness of each key. If some keys do not respond, replace user interface. If all keys are responsive, fault may be intermittent or caused by customer use. Check for vent and/or fan fault, which may lead to excessive moisture build up in door cavity and cause keys to appear stuck closed.
3 - Thermistor/ OWI	1 - Open or Shorted	<ul style="list-style-type: none"> - Open or shorted connection or component in temperature sensing circuit - Open, shorted or faulty temperature sensor - Temperature sensor input on control failed - Incoming water temperature above 167°F (75°C) 	<ol style="list-style-type: none"> 1. Unplug dishwasher or disconnect power. 2. Check all components and connections in the temperature sensing circuit with meter. Fix/replace open/shorted connection or part. 3. Verify incoming water temperature.
	2 - Failed Calibration	<ul style="list-style-type: none"> - OWI failure - OWI lens obstructed by hard water build up or food soil 	<ol style="list-style-type: none"> 1. Check OWI lens surface. Clean if needed. 2. Unplug dishwasher or disconnect power. 3. Check all connections in soil sensing circuit with meter. Fix/replace bad connection/part. <p>NOTE: Run diagnostics cycle after installing new OWI to force calibration on next regular wash cycle.</p>

For Service Technician Use Only Service Error Codes (Continued)

FUNCTION CODE	ERROR CODE	CAUSES	WHAT TO CHECK
4 - Heater	2 - Open*, Unplugged, or Failed Relay	<ul style="list-style-type: none"> - Open connection in heater circuit - Heater component open - Heater drive circuit on control <p>NOTE: Control will continue running cycles with no heat without alerting customer if this fault is detected.</p>	<ol style="list-style-type: none"> 1. Unplug dishwasher or disconnect power. 2. Measure resistance of heater and all components and connections in water heating circuit/heat dry circuit. Fix/replace open connection/part. <p>Advanced Diagnosis: If there is a F1E1 error code (on unit display) or F1E1-2 error code (when using service tool) then likely the heater relay is stuck open.</p>
	3 - Relay Shorted or Heater Failed	<ul style="list-style-type: none"> - Heater relay on control shorted - Heater component shorted to ground <p>NOTE: Control will continue running cycles with no heat without alerting customer if this fault is detected.</p>	<ol style="list-style-type: none"> 1. Unplug dishwasher or disconnect power. 2. Inspect heater and connections for overheating/shorting. If evidence of overheating or shorts exists, replace. 3. Measure resistance of heater and all components and connections in water heating circuit/heat dry circuit. Fix/replace open connection/part.
5 - Door Switch	1 - Door stuck open	Door was not latched within 4 seconds of pressing the Start/Resume key.	Instruct customer. Refer to Owner's Manual.
		Loose connection in door switch circuit and/or door switch contacts stuck open and/or door switch not making contact.	<ol style="list-style-type: none"> 1. Check strike plate and door closure force. Verify door seal is seated properly. Check for interference between dish racks and door. Try bending strike plate down for better engagement. 2. Unplug dishwasher or disconnect power. 3. Check resistances of door switch contacts and all connections in the door switch circuit with meter, while opening and closing the door latch.
		<ul style="list-style-type: none"> - Sloppy door latch assembly (Can be aggravated by high door closure force keeping strike plate from fully seating) - Door switch high resistance 	<ul style="list-style-type: none"> - If high resistance with door closed, check/fix loose connections. 4. Measure resistance of door switch contacts while checking mechanical operation of latch assembly. Check for broken plastic pieces on latch assembly. Replace latch if faulty.
	If none of the above	<ol style="list-style-type: none"> 1. With door open, verify 13 VDC present across P12-9 and P12-11. 2. If no voltage present, unplug dishwasher or disconnect power and replace control. 	
2 - Door stuck closed	Control programmed to not start if it suspects the door switch is stuck closed. Control looks for the door switch to open between cycles.	<ul style="list-style-type: none"> - Customer didn't open the door between cycles or door switch contacts stuck closed. 	<ol style="list-style-type: none"> 1. Open and close the door, select cycle, the press Start/Resume key. If cycle starts, instruct customer to open the door between cycles. 2. Unplug dishwasher or disconnect power. 3. Measure resistances of door switch contacts while checking mechanical operation of latch assembly. Fix/replace faulty components.

For Service Technician Use Only Service Error Codes (Continued)

FUNCTION CODE	ERROR CODE	CAUSES	WHAT TO CHECK
6 - User Interface	1 - No Response from ACU	<p>User interface has power but cannot communicate with main control board.</p> <ul style="list-style-type: none"> - Loose connection between UI and main control - Terminal or wire broken in harness between UI and main control - Main control communication circuit failed 	<ol style="list-style-type: none"> 1. Unplug dishwasher or disconnect power. 2. Access the control. Look for the LED sequence on the control and reference it to the ACU Diagnostic LED chart in section 3-3. If the LED has a slow blinking, the control is working normally and should not be replaced. If the LED is solid on, use the service tool to re-flash setting file. If the problem persists, continue to step 3. 3. Check connections between P1 on main control and user interface. Reconnect, repair, or replace harness. 4. If harness connections are all good, replace main control board.
7 - Wash Motor*	1 - Wash Motor Failure	<p>Loose connection in motor circuit and/or faulty wash motor.</p> <p>Advanced Diagnosis: If F1E1 is not detected, then likely only the wash motor and/or connectors require replacement.</p>	<ol style="list-style-type: none"> 1. Check operation of wash motor during diagnostics. 2. Unplug dishwasher or disconnect power. 3. Check resistances of connections in wash motor circuit. 4. Check for loose connections or replace wash motor.
		<p>Control motor drive circuit or sense circuit</p> <p>Advanced Diagnosis: If F1E1 is detected, then likely only the control require replacement.</p>	<ol style="list-style-type: none"> 1. Unplug dishwasher or disconnect power. 2. Check for other fault codes to see if F1E1 is also recorded. If meter check of wash motor circuit shows normal resistance and still not getting power to the wash motor, replace control only if there is also a F1E1 error code.
	4 - RIF Filter Plugged	<p>Clogged filter assembly</p> <p>Advanced Diagnosis: If F9E1 is not detected, then likely only the RIF filter requires cleaning.</p>	<ol style="list-style-type: none"> 1. Unplug the dishwasher or disconnect power. 2. Check the RIF filter assembly. Clean the filter and remove any soils from the filter area. Reassemble and reinstall Motor. <p>The images show what a clean and dirty filter look like when looking through the opening with the drain pump removed.</p> <div style="display: flex; justify-content: center; gap: 20px;">   </div> <ol style="list-style-type: none"> 3. Verify that the unit is operating with normal motor resistance, voltage is in the normal range, and the wash pressures sound strong. Run the diagnostic cycle to ensure there are no error codes. 4. Run a service diagnostic cycle as last verification. 5. If problem persist, then replace motor and sump assembly. <p>Check for other fault codes to see if F9E1 is also recorded. See F9E1 description.</p>

**For Service Technician Use Only
Service Error Codes (Continued)**

FUNCTION CODE	ERROR CODE	CAUSES	WHAT TO CHECK
8 - Inlet Water	1 - No Water / Tap Closed	No water to dishwasher	Verify water supply is turned on and supply line adequate. Check for kinked fill hose.
		Bowls or pots loaded or flipped upside down and captured wash water	Instruct customer on loading. Refer to Owner's Manual.
		Water leaking from dishwasher	Check for leaks under dishwasher.
		Fill valve or water line plugged with debris	Turn off water supply to dishwasher, disconnect water line to inlet valve and inspect/clean the inlet screen of fill valve and reconnect water line.
		Fill valve electrical problem	Check other fault codes to see if F8E2 is also recorded. See F8E2 description below.
		Flow meter intermittent or failed	Check other fault codes to see if F8E6 is also recorded. See F8E6 description below.
	2 - Fill valve electrical problem	Loose connection in fill valve circuit and/or open fill valve solenoid	<ol style="list-style-type: none"> 1. Unplug dishwasher or disconnect power. 2. Check resistances of fill valve solenoid and all connections in the fill circuit with meter. 3. Fix/replace open connection/part.
		Open fuse on control to fill valve	Refer to " Fuse Service and Resistance Check " in section 3.
		Faulty fill valve drive circuit on control	<ol style="list-style-type: none"> 1. Unplug dishwasher or disconnect power. 2. Check resistances of fill valve solenoid and all connections in the fill circuit. If all connections and solenoid measure good, replace control.

For Service Technician Use Only Service Error Codes (Continued)



FUNCTION CODE	ERROR CODE	CAUSES	WHAT TO CHECK
8 - Inlet Water	3 - Very Low Water / Suds / Air in Pump	Too many suds	<ol style="list-style-type: none"> 1. Start a cycle, allow unit to fill and wash for 1-2 minutes. Open door and check for excessive sudsing. 2. Confirm using proper dishwasher detergent, not hand detergent. 3. Check for excessive rinse aid leakage. Disconnect power and replace dispenser if rinse aid is leaking.
		Bowls or pots loaded or flipped upside down and captured wash water	Instruct customer on loading. Refer to Owner's Manual.
		Water leaking from dishwasher	Check for leaks under dishwasher.
		Diverter disk in sump missing	Remove lower spray arm, rear feedtube, and outlet cover and verify whether the diverter disk is installed.
	4 - Overfill switch open	Damaged Harness	Wire harness and/or connector may have been damaged during installation. Replace if damaged.
		Overfill switch unplugged	Remove access panel and inspect overfill switch assembly. Ensure connector is fully seated.
		Water in leak pan under unit	<p>Remove access panel and check for water in leak pan. If water present, unplug float switch, remove pan and empty it. Replace pan and reconnect the switch. Press Cancel key twice to remove unit from error mode. Verify that fault code is not re-detected by control.</p> <p>NOTE: Root cause of overfill must be corrected or customer will experience another overfill and service call in the future.</p>
		Overfill switch stuck in open/up position	<ol style="list-style-type: none"> 1. Remove access panel and inspect overfill switch assembly and pan for water or obstruction. Verify that Styrofoam float is able to move freely and you hear the "click" of switch contacts when it is down. 2. Unplug dishwasher or disconnect power and check resistance of overfill switch. Switch should be shorted when float is down.
		Drain issue	Check other fault codes to see if F9E1 and/or F9E2 have been recorded. See info for these fault codes below.
		Fill valve mechanically stuck open	Check other fault codes to see if F8E5 is also recorded. See info for F8E5 below.
		Fill valve triac on control shorted	Check other fault codes to see if F1E1 is also recorded. See info for F1E1 above.
		Unit not level and water surges down overfill funnels into leak pan during cycle	Check levelness of dishwasher. If unit is tilted forward, water is more likely to enter funnels and fill leak pan. Adjust unit until level. Empty leak pan.
		Air pressure surges when door is opened and immediately closed while dishwasher is hot can force water droplets down funnels into leak pan.	Instruct customer to leave dishwasher open a few minutes if door is opened when unit is hot. Empty leak pan.
		Too many suds	<ol style="list-style-type: none"> 1. Start a cycle, allow unit to fill and wash for 1-2 minutes. Open door and check for excessive sudsing. 2. Confirm using proper dishwasher detergent, not hand detergent. 3. Check for excessive rinse aid leakage. Disconnect power and replace dispenser if rinse aid is leaking.

For Service Technician Use Only Service Error Codes (Continued)

FUNCTION CODE	ERROR CODE	CAUSES	WHAT TO CHECK
8 - Inlet Water	5 - Fill valve stuck open*	Control detects water flowing through flow meter when fill valve is turned off Advanced Diagnosis: If there is no F1E1 detected, then likely only the fill valve requires replacement.	Confirm dishwasher fills while door is open. - If yes, unplug dishwasher or disconnect power, turn off water to dishwasher, replace fill valve and turn water back on. - If filling stops with door open, but fault is detected while running a cycle, unplug dishwasher or disconnect power and replace control.
		Fill valve TRIAC on control shorted Advanced Diagnosis: If F1E1 is detected, then likely only the control requires replacement.	If dishwasher does not fill with door open, but F8E5 or F1E1 is detected while cycle is running, the fill valve TRIAC is shorted. Disconnect power and replace control.
	6 - Flow meter	Disconnected or damaged flow meter NOTE: Control is programmed to default to timed fill sequence if flow meter malfunctions. Intermittent flow meter connection may cause incorrect fill levels or false fault codes to be recorded. NOTE: F8E6 blocks all other error codes from being displayed to customer and Service Tool. All other error codes can only be viewed in service mode. Address F8E6 first and clear codes before running diagnostic test to diagnose other codes.	<ol style="list-style-type: none"> 1. Unplug dishwasher or disconnect power. 2. Check connections to flow meter with meter. Verify that connector is securely connected at the flow meter end and wires are not pinched/damaged. Reconnect wires and/or replace damaged components. 3. Inspect water inlet and flow meter for signs of obstruction that prevent flow meter wheel from turning. If wheel does not turn, or turns intermittently, when water is flowing, replace water inlet assembly.
9 - Draining (Check electrical loads first, mechanical functions second)	1 - Not draining	Drain motor electrical problem	Check other fault codes to see if F9E2 is also recorded. See F9E2 description below. F9E1 is not likely caused by a drain pump electrical issue, unless also accompanied by a F9E2. Do not change the drain pump without confirming it has either failed electrically, mechanically seized, or chopper blade failed.
		Wash motor problem or clogged RIF filter.	<ol style="list-style-type: none"> 1. Check other fault codes to see if F7E1 or F7E4 is also recorded. Control uses wash motor signal to verify drain so a failed wash motor can cause a drain fault to be detected. 2. Check wash motor and filter assembly for proper function. 3. Check motor resistance and voltage are in normal operating range. 4. Remove drain pump and check if filter is clogged by looking through the opening. Reference F7E4 for example. The image below is what a dirty filter may look like.
		Obstructed drain hose or path	<ol style="list-style-type: none"> 1. Unplug dishwasher or disconnect power. 2. Check for blockages from drain motor to customer's plumbing. Check for plugged garbage disposal or plug not knocked out, plugged hoses or drain check valve stuck.



For Service Technician Use Only Service Error Codes (Continued)

FUNCTION CODE	ERROR CODE	CAUSES	WHAT TO CHECK
9 - Draining (Check electrical loads first, mechanical functions second)	1 - Not draining	Drain pump impeller damaged	<ol style="list-style-type: none"> 1. Unplug dishwasher or disconnect power. 2. Remove drain pump and check impeller (normally there is some uneven resistance when pushing it). If it is stripped or visibly damaged, replace drain pump.
		Intermittent over heat instance to lock up.	<p>NOTE: In many cases, the pump cools down and will operate again</p> <p>For intermittent pump locking, check the following:</p> <ul style="list-style-type: none"> - Resistance provided in specification. - Harness wiring to the pump for continuity. - Voltage at the pump. - Then remove the drain pump and check for axial play. - If the axial play is fine, also check for motor short or open. - If all checks are acceptable, change the pump to assume that it has the rare intermittent instance. - Replacement parts are not likely to have the same condition.
	2 - Drain motor electrical problem	Loose connection in drain motor circuit and/or open drain motor winding.	<ol style="list-style-type: none"> 1. Unplug dishwasher or disconnect power. 2. Check resistances of drain motor winding and all connections in the drain circuit. Fix/replace open connection/part.
		Debris stuck in drain motor impeller causing locked rotor	<ol style="list-style-type: none"> 1. Unplug dishwasher or disconnect power 2. Remove drain motor and dislodge debris from impeller. Inspect for damage before reassembling.
		Open fuse on control to drain motor	Refer to " Fuse Service and Resistance Check " in section 3.
		Drain motor drive circuit on control	<ol style="list-style-type: none"> 1. Unplug dishwasher or disconnect power. 2. Check resistances of drain motor winding and all connections in the drain circuit. If all connections and drain motor winding measure good, replace control.
		Thermal cutoff switch	<p>Wait 5 minutes, the cutoff should cool. Then test the resistance of the drain pump. If the resistance was previously infinite, but now has a integer value, the cutoff had opened. If the product had an F9E2 and the cause was the cutoff opening the circuit, change the drain pump.</p> <div style="display: flex; justify-content: center; gap: 20px;">   </div>
	4 - Light in the tub	Loose connection or open circuit in tub light circuit	<ol style="list-style-type: none"> 1. Unplug dishwasher or disconnect power. 2. Check resistances of tub lights and all connections in tub light circuit. Fix/replace open connection/part.

For Service Technician Use Only
Service Error Codes (Continued)

FUNCTION CODE	ERROR CODE	CAUSES	WHAT TO CHECK
10 (A) - Other	1 - Dispenser electrical problem	Loose connection in dispenser circuit and/or open dispenser solenoid	<ol style="list-style-type: none"> 1. Unplug dishwasher or disconnect power. 2. Check resistances of dispenser solenoid and all connections in the dispenser circuit. Fix/replace open connection/part.
		Open fuse on control to dispenser	Refer to " Fuse Service and Resistance Check " in section 3.
		Dispenser drive circuit on control	<ol style="list-style-type: none"> 1. Unplug dishwasher or disconnect power. 2. Check resistances of dispenser solenoid and all connections in the dispenser circuit. If all connections and solenoid measure good, replace control.
	2 - Vent electrical problem	Loose connection in vent circuit and/or open vent wax motor.	<ol style="list-style-type: none"> 1. Clear error codes. Run service cycle test and see if F10E2 reappears. If so, continue to step 2. 2. Unplug dishwasher or disconnect power. 3. Check resistances of vent wax motor and all connections in the vent circuit. Fix/replace open connection/part.
		Open fuse on control to vent.	Refer to " Fuse Service and Resistance Check " in section 3.
		Vent drive circuit on control.	<ol style="list-style-type: none"> 1. Unplug dishwasher or disconnect power. 2. Check resistances of vent wax motor and all connections in the vent circuit. If all connections and wax motor measure good, replace control.
	3 - Drying fan electrical problem	Loose connection in fan circuit and/or open fan motor winding.	<ol style="list-style-type: none"> 1. Unplug dishwasher or disconnect power. 2. Check resistances of fan motor and all connections in the fan circuit. Fix/replace open connection/part.
		Fan drive circuit on control.	<ol style="list-style-type: none"> 1. Unplug dishwasher or disconnect power. 2. Check resistances of fan motor and all connections in the fan circuit. If all connections and fan motor measure good, replace control.
	10 (A) - Other	4 - Diverter can't find positions (Position optical sensor, spray arms)	Corroded or loose connection in diverter sensor or motor circuit. Open/shorted diverter sensor or motor.
5 - Diverter leak (Motor)		Corroded or loose connection in diverter sensor circuit.	<ol style="list-style-type: none"> 1. Unplug dishwasher and disconnect power. 2. Check connections in diverter sensor circuit with meter. Fix/replace connections/parts.
		Leak at diverter seal	<ol style="list-style-type: none"> 1. Inspect diverter for evidence of water or contaminants; if yes, replace. 2. Check for residue buildup around the diverter area and connections. 3. Check for a leak or the appearance of error code again while running the service diagnostics cycle. 4. After that, run a quick/normal cycle for 10 minutes or a longer observation time. 5. Replace the entire sump assembly: <ul style="list-style-type: none"> - If any leakage is found or, - If troubleshooting is not successful or, - If you get an error code.

**For Service Technician Use Only
Troubleshooting Guide**

⚠ DANGER

<p align="center">Electrical Shock Hazard</p> <p>Only authorized technicians should perform diagnostic voltage measurements.</p> <p>After performing voltage measurements, disconnect power before servicing.</p> <p>Failure to follow these instructions can result in death or electrical shock.</p>

NOTES:

- For resistance checks, refer to the [“Dishwasher Strip Circuits”](#) in Section 3.
- For checking operation with diagnostics, refer to [“Service Diagnostics Cycle Timing”](#) section.

CUSTOMER DESCRIPTION	POTENTIAL CAUSES	CHECK	RELATED ERROR CODES
CLEAN LED Flashes	Control Programmed with Self Diagnostics	Read error code from the dishwasher and refer to “Service Error Codes” table. Run service diagnostics test cycle to read full history of error codes.	F1E1 F8E1 F8E4 F8E5 F9E1 F10E4 (FAE4)

For Service Technician Use Only Troubleshooting Guide (Continued)

CUSTOMER DESCRIPTION	POTENTIAL CAUSES	CHECK	RELATED ERROR CODES
Won't run or power up ("Dead" keypad/console) ■ No operation ■ No keypad response ■ No LEDs or display	No power to unit or bad connection	Check fuses, circuit breakers, and junction box connections.	
	Loose connections in dishwasher power up circuit or between keypad(s) and control	1. Unplug dishwasher or disconnect power. 2. Check continuity power connections keypad(s) and control.	
	User interface on this model is not compatible with control which has been exchanged with a control from another model.	Unplug dishwasher or disconnect power. Verify correct control is installed for this model. Control is specific to each user interface and model type. Call techline to verify part numbers if necessary. If incorrect control, replace.	
	Control detected door switch problem	Refer to " Service Error Codes " table	F5E1
	User interface or control failure	1. Unplug dishwasher or disconnect power. 2. Replace user interface/console and/or control.	
Won't run and Start/Resume LED is blinking slowly	By design, if door is opened for more than 5 seconds or power is interrupted during a cycle, the user must press Start/Resume to resume operation.	Instruct customer. Refer to Owner's Manual.	
	Start/Resume key not responding	See "One or more keys won't respond."	
	Control detected door switch problem.	Refer to " Service Error Codes " table.	F5E1
Won't start and Start/Resume LED flashes 3 times when Start/Resume key is pressed	Control looking for door to open between cycles: - Customer has not opened door since last cycle - Door switch contacts stuck closed	Refer to " Service Error Codes " table.	F5E2
Won't accept key presses and Control Lock LED on	Control lockout feature accidentally enabled by customer.	Instruct customer. Refer to Owner's Manual. Press and hold Control Lock key for 5 seconds to disable lockout feature.	
One or more keys won't respond or unusual key/LED/display behavior	Stuck key or short circuits in keypad or in user interface's input lines that read the keys.	Refer to " Service Error Codes " table	F2E1
	Capacitive touch keypad adhesive coming loose from console.	1. Unplug dishwasher or disconnect power. 2. Inspect keypad board for separation from console. Replace keypad/console if separation is seen.	
	Loose connections between keypad and control and/or bent connector pins	1. Unplug dishwasher or disconnect power. 2. Inspect connections in user interface circuits. Reconnect loose connections. Replace parts if pins are damaged or contaminated.	F6E1
	Excessive condensation on user interface parts due to vent and/or fan problem	Check fault code history for vent and/or fan faults. Refer to " Service Error Codes " table. Verify that vent closes and fan turns on. Refer to "Leaks or drips on cabinet or floor."	F10E2 (FAE2) F10E3 (FAE3)
	User interface failure	1. Unplug dishwasher or disconnect power. 2. Replace user interface.	

**For Service Technician Use Only
Troubleshooting Guide (Continued)**

CUSTOMER DESCRIPTION	POTENTIAL CAUSES	CHECK	RELATED ERROR CODES
Dishwasher beeps constantly	User opened door during cycle and closed door without pressing Start/Resume key to resume cycle.	Instruct customer. Control is designed to beep if dishwasher is in "cycle interrupt" mode with door latched. Control will stop beeping when door is open and/or when Start/Resume key is pressed to resume cycle.	
	Normal beeper operation is excessive to customer.	Instruct customer how to turn beeper off and on. Refer to Owner's Manual.	
	Control is programmed to stop cycle and alert customer when certain fault codes have been detected.	Press Cancel key once to silence alarm during fault mode. Read error code from the dishwasher and refer to " Service Error Codes " table. Use service diagnostics mode to get fault history from appliance.	F1E1 F8E1 F8E4 F8E5 F9E1 F10E4 (FAE4)
LEDs or displays run for a short time without loads running or wash motor runs without attempt to fill or fan is the only load that runs	Unit is in sales demo mode	Check operation of Cancel key. If pressing cancel multiple times does not activate Cancel/Drain sequence, unit is likely in sales demo mode. To clear demo mode, cycle power for at least 1 minute or run service diagnostics cycle.	
	Open fuse on control removed power from loads	Refer to " Fuse Service and Resistance Check " in section 3.	
Long cycles and/or stuck in certain parts of the cycle	As part of normal operation, the dishwasher pauses 2 or 3 times during the cycle for thermal holds and advances once temperature is met.	Instruct customer. Explain thermal holds and how the cycle timing pauses when they occur.	
	OWI soil sensor picking high soil cycle too often.	<ol style="list-style-type: none"> 1. Check lens surface. Clean if needed. 2. If lens surface cannot be cleaned or has visible damage, unplug dishwasher or disconnect power. 3. Replace OWI and run diagnostics cycle after installing new OWI to force calibration on next customer wash cycle. 	
	Diverter problem prevents water from heating efficiently.	Refer to " Service Error Codes " table.	F10E5 (FAE5)
	A water heating problem can cause long cycles, but will typically also cause a water heating fault code.	Refer to " Service Error Codes " table.	F4E2 F4E3
	Heater takes a long time to heat water with low voltage	Check for at least 100 VAC at power source.	
	Incoming water under 84°F (29°C)	<ol style="list-style-type: none"> 1. Ensure dishwasher is connected to the hot water supply. 2. Confirm temperature at sink. Recommended is 120°F (49°C). 3. Unplug dishwasher or disconnect power and check all connections and measure resistance in temperature sensing circuit. Reconnect and/or replace parts. 	
	Suds or air in pump requires repeated wash periods.	Refer to " Service Error Codes " table.	
OWI or NTC temperature sensor problem	Refer to " Service Error Codes " table.	F3E1	

For Service Technician Use Only Troubleshooting Guide (Continued)

CUSTOMER DESCRIPTION	POTENTIAL CAUSES	CHECK	RELATED ERROR CODES
Can start a cycle but only runs for a short time. Cycle does not complete (Clean or Complete LED may blink).	Control is programmed to stop cycle and alert customer when certain fault codes have been detected.	Press Cancel key once to silence alarm during fault mode. Read error code from the dishwasher and refer to " Service Error Codes " table. Use service diagnostics mode to get fault history from appliance.	F1E1 F8E1 F8E4 F8E5 F9E1 F10E4 (FAE4)
	Unit is in sales demo mode	Check operation of Cancel key. If pressing cancel multiple times does not activate Cancel/Drain sequence, unit is likely in sales demo mode. To clear demo mode, cycle power for at least 1 minute or run service diagnostics cycle.	
Will not drain or water left in dishwasher	Draining problem	Refer to " Service Error Codes " table.	F9E1 F9E2
	Customer misunderstands water level after drain	Instruct customer. Sump will normally have up to an inch of water remaining in filter area after cycle.	F7E4
	Clogged RIF filter	<ol style="list-style-type: none"> Unplug dishwasher or disconnect power. Check RIF filter assembly. Clean remove any soils from filter area. Reassemble and reinstall Motor. 	F7E4
Detergent not dispensing or detergent left in dispense NOTE: Check error history. If no fault for electrical problems, problem is mechanical. Do not replace control.	Item in lower rack blocked dispenser from opening or blocked spray of water to dispenser.	Instruct customer on proper dish loading.	
	Mechanical binding of dispenser lid	<ol style="list-style-type: none"> Unplug dishwasher or disconnect power. Replace dispenser. 	
	Lid latch binding due to excess detergent in mechanism	Instruct customer on proper dispenser filling.	
	Dispenser electrical problem	Refer to " Service Error Codes " table.	F10E1 (FAE1)
	Control canceled cycle prior to dispensing due to fault detected.	Read error code from the dishwasher and refer to " Service Error Codes " table. Use service diagnostics mode to get fault history from appliance.	F1E1 F8E1 F8E4 F8E5 F9E1 F10E4 (FAE4)
Film or spots on glasses and/or dishes	Customer not using rinse aid and/or Heated Dry	Check rinse aid level in dispenser. Instruct customer how to fill and monitor level of rinse aid.	
	Rinse Aid dispenser problem	Refer to " Service Error Codes " table.	F10E1 (FAE1)
	Hard water leaving film on dishes	Check water hardness. If hard water present, instruct customer to use dishwasher cleaner per packaging instructions. Also recommend 1 Hour Wash cycle.	
		Rinse aid dosage insufficient for hardness of water. Instruct customer on how to access customer setting menu to increase rinse aid dosage. Refer to Owner's Manual.	
	Detergent carry-over causing oversudsing	Check water hardness. If below 10 grains, instruct customer to use less detergent. Recommend using 1 Hour Wash cycle.	

**For Service Technician Use Only
Troubleshooting Guide (Continued)**

CUSTOMER DESCRIPTION	POTENTIAL CAUSES	CHECK	RELATED ERROR CODES
Film or spots on glasses and/or dishes	Etching of glass from too much detergent at high temperature	Check water hardness. If below 10 grains, instruct customer to use less detergent. Recommend using 1 Hour Wash cycle.	
	Diverter problem	Refer to " Service Error Codes " table	F10E5 (FAE5)
Poor wash	Cycle selection of customer not appropriate for dish load	Instruct customer on cycle selection. Recommend "High Temp" option for a wash performance boost.	
	Dishes not loaded facing nozzles	Instruct customer on proper dish loading and spray arm coverage. Refer to Owner's Manual.	
	Plugged or damaged filter	<ol style="list-style-type: none"> Place mugs or glasses upright in the middle and lower dish racks. Run a Normal cycle for 10-15 minutes. Open the door and inspect mugs. If water is accumulating in them, pump is working. If no water is present, water is not being pumped through the spray arms. If no diverter or wash motor fault recorded, filter may be plugged or damaged. Unplug dishwasher or disconnect power. Replace pump/filter assembly. 	
	Little or no wash pump flow	<p>Diverter problem. Refer to "Service Error Codes" table.</p> <ol style="list-style-type: none"> Filter may be plugged with food soil or hard water. Place mugs or glasses upright in the middle and lower dish racks. Run a Normal cycle for 10-15 minutes. Open the door and inspect mugs. <ul style="list-style-type: none"> If water is accumulating in them, pump is working. If no water is present, water is not being pumped through the spray arms. Inspect pump/filter assembly. If filter is plugged or damaged, unplug dishwasher or disconnect power and replace pump/filter assembly. If hard water is present, instruct customer on proper maintenance. 	F10E5 (FAE5)
Spray arms not rotating or plugged	<ol style="list-style-type: none"> Check arm rotation. If arms are blocked by dish item, instruct customer. Also check for correct upper spray arm alignment with docking station located on feed tube at back tub wall. Check nozzles. If they are plugged, clean nozzles. Plugging may be caused by hard water build up in water delivery system or damaged pump filter. Inspect water delivery system and clean as needed. Inspect pump/filter assembly. Clean or replace. 		

For Service Technician Use Only Troubleshooting Guide (Continued)

CUSTOMER DESCRIPTION	POTENTIAL CAUSES	CHECK	RELATED ERROR CODES
Poor wash	Poor wash due to draining, dispensing and/or temperature problems.	Refer to “Will not drain”, “Detergent not dispensing” or “Long cycles” sections above. Refer to “ Service Error Codes ” table.	
	Soil sensor is choosing low soil cycle when high soil is present.	<ol style="list-style-type: none"> 1. Check lens surface. Clean if needed. 2. If sensor cannot be cleaned or has visible damage, unplug dishwasher or disconnect power. 3. Replace OWI and run diagnostics cycle after installing new OWI to force calibration on next customer wash cycle. 	
	Diverter problem	Refer to “ Service Error Codes ” table.	
	Diverter disk in sump is missing	Remove lower spray arm, rear feedtube, and outlet cover and verify whether the diverter disk is installed.	
	Heating problem	Refer to “ Service Error Codes ” table.	F4E2 F4E3
	Control is programmed to stop cycle and alert customer when certain fault codes have been detected.	<ol style="list-style-type: none"> 1. Press Cancel key once to silence alarm during fault mode. 2. Read error code from the dishwasher and refer to “Service Error Codes” table. 3. Use service diagnostics mode to get fault history from appliance. 	F1E1 F8E1 F8E4 F8E5 F9E1 F10E4 (FAE4)
Poor dry	Customer not using rinse aid and/or dispenser empty	Check rinse aid level in dispenser. Instruct customer how to fill and monitor level of rinse aid. Some wetness may be present. Recommend use of rinse aid with Heated Dry or Extended Dry to customer.	
	Customer not using Heated Dry option	Some wetness may be present. Recommend use of Rinse Aid with Heated Dry or Extended Dry to customer.	
	Rinse aid dispenser problem	Refer to “ Service Error Codes ” table.	F10E1 (FAE1)
	Fan problem	Refer to “ Service Error Codes ” table.	F10E3 (FAE3)
	Heating problem	Refer to “ Service Error Codes ” table.	F4E2 F4E3
	Control is programmed to stop cycle and alert customer when certain fault codes have been detected.	Press Cancel key once to silence alarm during fault mode. Read error code from the dishwasher and refer to “ Service Error Codes ” table. Use service diagnostics mode to get fault history from appliance.	F1E1 F8E1 F8E4 F8E5 F9E1 F10E4 (FAE4)
Sanitized LED blinks or incomplete sanitization message at end of cycle (Control could not confirm sanitization achieved)	Door opened during final rinse or dry	Instruct customer	

**For Service Technician Use Only
Troubleshooting Guide (Continued)**

CUSTOMER DESCRIPTION	POTENTIAL CAUSES	CHECK	RELATED ERROR CODES
Sanitized LED blinks or incomplete sanitization message at end of cycle (Control could not confirm sanitization achieved)	Incoming water under 84°F (29°C)	<ol style="list-style-type: none"> 1. Ensure dishwasher is connected to the hot water supply. 2. Confirm temperature at sink. Recommended is 120°F (49°C). 3. Unplug dishwasher or disconnect power and check all connections and measure resistance in temperature sensing circuit. Reconnect and/or replace parts. 	
	Heating problem	Refer to " Service Error Codes " table.	F4E2 F4E3
	Thermistor/OWI sensor problem	Refer to " Service Error Codes " table.	F3E1 F3E2
	Loose or intermittent connection in door switch circuit: <ul style="list-style-type: none"> - Sloppy door latch assembly (Can be aggravated by high door closure force keeping strike plate from fully seating). 	<ol style="list-style-type: none"> 1. Check strike plate and door closure force. Verify door seal is seated properly. Check for interference between dish racks and door. Try bending strike plate down for better engagement. 2. Unplug dishwasher or disconnect power. 3. Check resistances of door switch contacts and all connections in the door switch circuit with meter, while opening and closing the door latch. <ul style="list-style-type: none"> - If high resistance with door closed, check/fix loose connections. 4. Measure resistance of door switch contacts while checking mechanical operation of latch assembly. Check for broken plastic pieces on latch assembly. Replace latch if faulty. 	
	Line voltage too low to heat fast enough for sanitization	Confirm at least 100 VAC at power source.	
	Air pressure surges due to washing with high suds causes brief opening of door switch contacts during final rinse.	Refer to " Service Error Codes " table.	F8E3
Melted dishware and/or spray arm and/or dishwasher always hot	Customer uses non-dishwasher safe dishes or loads plastic dishes directly over heater	Instruct customer.	
	Temperature sensing problem	Refer to " Service Error Codes " table.	F3E1
	Heating problem	Refer to " Service Error Codes " table.	F4E2 F4E3
	Heater displaced from mounting clip and/or pulled off center	Inspect heater. Adjust back into position if needed.	
Noisy operation	Spray arm stalled or blocked and spraying on door	<ul style="list-style-type: none"> - Instruct customer if blocked - Check spray arm rotation and check for plugged nozzles. If plugged, clean nozzles and inspect filters. 	
	Diverter problem	Refer to " Service Error Codes " table.	F10E5 (FAE5)
	No or low water	Refer to " Service Error Codes " table.	F8E1 F8E2 F8E3

For Service Technician Use Only Troubleshooting Guide (Continued)

CUSTOMER DESCRIPTION	POTENTIAL CAUSES	CHECK	RELATED ERROR CODES
Noisy operation	Drain periods are too long	Control is programmed to run drain until complete. Long or partially obstructed drain hose may cause long drain periods. Run Service cycle and verify that drain is completed in approximately 1 minute. If drain is long, inspect drain path from dishwasher to customer's plumbing for issues.	
	Loose connection in vent circuit and/or open vent wax motor	Unplug dishwasher or disconnect power and check resistances of vent wax motor and all connections in vent circuit. Fix/replace open connections/part.	F10E2 (FAE2)
	Open fuse on control to vent wax motor	Refer to " Fuse Service and Resistance Check " in section 3.	
	Vent drive circuit on control failed	Unplug dishwasher or disconnect power and check resistances of vent wax motor and all connections in vent circuit. Fix/replace open connections/part.	
	Fan runs (makes noise) after cycle complete (On models with fan)	Dishwasher is designed to keep fan running after cycle to prevent moisture build up in dishwasher. Fan will turn off if door opened longer than 5 seconds. Instruct customer.	
	Excessive fan noise due to faulty fan motor (On models with fan)	<ol style="list-style-type: none"> 1. Check fan operation during Service cycle. 2. Unplug dishwasher or disconnect power. 3. Check resistances of fan motor and all connections in fan circuit. Fix/replace open connections/part. 	
Leaks or drips on cabinet or floor	Loose connection in vent circuit and/or open vent wax motor	Unplug dishwasher or disconnect power and check resistances of vent wax motor and all connections in vent circuit. Fix/replace open connections/part.	F10E2 (FAE2)
	Open fuse on control to vent wax motor	Refer to " Fuse Service and Resistance Check " in section 3.	
	Vent drive circuit on control failed	Unplug dishwasher or disconnect power and check resistances of vent wax motor and all connections in vent circuit. Fix/replace open connections/part.	
	Fan problem	Refer to " Service Error Codes " table.	F10E3 (FAE3)
	Too many suds	Refer to " Service Error Codes " table.	F8E3
	Leaking dishwasher	Check door/tub gasket and all water connections below dishwasher. Refer to " Service Error Codes " table.	F8E4
Leaks or drips on cabinet or floor	Unit not level and water surges over front tub lip or down overflow funnels during cycle	Check levelness of dishwasher. If unit is tilted forward, water is more likely to enter funnels and fill leak pan. Adjust unit until level. Inspect leak pan and empty if needed.	F8E4
	Air pressure surges when door is opened and immediately closed while dishwasher is hot can force water droplets out vent duct or down funnels into leak pan.	Instruct customer to leave dishwasher open a few minutes if door is opened when unit is hot. Inspect leak pan and empty if needed.	F8E4

**For Service Technician Use Only
Troubleshooting Guide (Continued)**

CUSTOMER DESCRIPTION	POTENTIAL CAUSES	CHECK	RELATED ERROR CODES
Leaks or drips on cabinet or floor	Air pressure surges when door is opened and immediately closed while dishwasher is hot can force water droplets out vent duct or down funnels into leak pan.	Recommend use of rinse aid with Heated Dry or Extended Dry to customer.	

Section 3: Component Testing

This section provides the component location for the "KitchenAid® and Maytag® 24" Microfiltration Dishwashers."

- Safety
- Service Tool Connection Location
- Control Board Information
- Component Testing
- Component Location

For Service Technician Use Only

Safety

⚠ DANGER

<p style="text-align: center;">Electrical Shock Hazard</p> <p>Only authorized technicians should perform diagnostic voltage measurements.</p> <p>After performing voltage measurements, disconnect power before servicing.</p> <p>Failure to follow these instructions can result in death or electrical shock.</p>

⚠ WARNING

<p style="text-align: center;">Electrical Shock Hazard</p> <p>Disconnect power before servicing.</p> <p>Replace all parts and panels before operating.</p> <p>Failure to do so can result in death or electrical shock.</p>

<p>Voltage Measurement Safety Information</p> <p>When performing live voltage measurements, you must do the following:</p> <ul style="list-style-type: none">■ Verify the controls are in the off position so that the appliance does not start when energized.■ Allow enough space to perform the voltage measurements without obstructions.■ Keep other people a safe distance away from the appliance to prevent potential injury.■ Always use the proper testing equipment.■ After voltage measurements, always disconnect power before servicing.

<p>IMPORTANT: Electrostatic Discharge (ESD) Sensitive Electronics</p> <p>ESD problems are present everywhere. ESD may damage or weaken the electronic control assembly. The new control assembly may appear to work well after repair is finished, but failure may occur at a later date due to ESD stress.</p> <ul style="list-style-type: none">■ Use an antistatic wrist strap. Connect wrist strap to green ground connection point or unpainted metal in the appliance <p style="text-align: center;">-OR-</p> <p style="text-align: center;">Touch your finger repeatedly to a green ground connection point or unpainted metal in the appliance.</p> <ul style="list-style-type: none">■ Before removing the part from its package, touch the antistatic bag to a green ground connection point or unpainted metal in the appliance.■ Avoid touching electronic parts or terminal contacts; handle electronic control assembly by edges only.■ When repackaging failed electronic control assembly in antistatic bag, observe above instructions.

For Service Technician Use Only

⚠ DANGER



Electrical Shock Hazard

Only authorized technicians should perform diagnostic voltage measurements.

After performing voltage measurements, disconnect power before servicing.

Failure to follow these instructions can result in death or electrical shock.

DW03G WIN Port Location 2023+

The products produced from late 2023, will have a WIN Port located behind the toe panel or access cover. Follow all instructions in Technical Manual, [W11509149](#). Remove the toe panel or access cover. Using the Blue Service Tool Wire assembly, connect the Service Tool to the WIN Port.

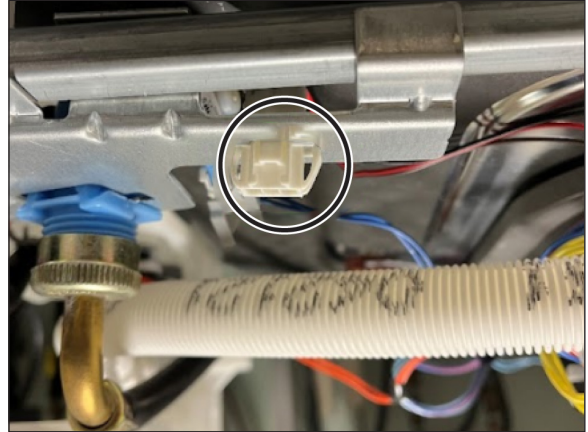

Service Tool Connection Location

This series of dishwashers is equipped with a data port used by manufacturing and service. The data port is referred to as WIN port, and the data line and circuit is referred to as WIN. For more information about WIN and Service Tool, refer to the cross category Technical Manual, [W11509149](#).

Capability

Most of the capability related to Service Tool is embedded on the Tool or the related App. This means that new capability in many cases will be added to the App, meaning products compatible with Service Tool but already in the field, will also benefit from App enhancements and updates. Currently the App is capable of flashing Firmware and Settings Files. In the future, additional capabilities to the App will be added. Refer to the latest cross category Technical Manual, [W11509149](#) for the latest App capabilities.

DW03G WIN Port Location 2019-2023

The products produced from 2019 into late 2023, will have a WIN Port located within the door assembly. Follow all instructions in Technical Manual, [W11509149](#). Remove the outer door panel. Open the plastic cover on the right side of the ACU to access the P3 Connector. Using the Black Service Tool Wire assembly, connect the Service Tool to the ACU.

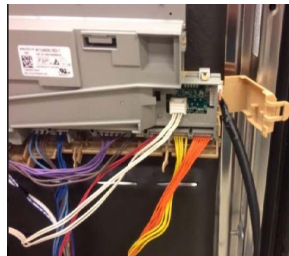

For Service Technician Use Only

⚠ DANGER



Electrical Shock Hazard

Only authorized technicians should perform diagnostic voltage measurements.

After performing voltage measurements, disconnect power before servicing.

Failure to follow these instructions can result in death or electrical shock.

Control Board Information

Specifications

Electrical Supply: (Under Load): 60 Hz 120 VAC

Supply Water Flow Rate: To fill 2 qt (1.9 L) in 46 seconds, 120 psi maximum, 20 psi minimum.

Supply Water Temperature: 120°F (49°C) (Before starting a cycle, run water from sink faucet until hot).

Water Charge: 1.0 gal. (3.9 L) Approximate

Lower Spray Arm Rotation: 12 to 40 RPM

Upper Spray Arm Rotation: 12 to 30 RPM

Fuse Service and Resistance Check

F500 = Small - TRIAC Load Fuse

Check operation of loads during the Service Diagnostics cycle.

- If any of the TRIAC loads work, F500 Fuse is OK.
- If all TRIAC loads fail to work, F500 Fuse could be open. See Fuse Resistance Check.

Fuse Resistance Check:

1. Unplug the dishwasher or disconnect power.
2. Measure resistance of F500 Fuse.

NOTE: Fuses are on the bottom of the Control Board but can be checked from the top side. See "[Control Pin-out](#)" diagram.

- If resistance is < 3 Ω, then fuse is OK.
- If resistance is > 3 Ω, then fuse is OPEN.

If the fuse is open:

Inspect and check resistance of all loads on fuse. If any loads are open, shorted, or have evidence of overheating or pinched wires, replace them.

Component Testing

Testing Dishwasher Components from the Control

Before testing any of the components, perform the following checks:

- The most common cause for mis-diagnosed control failure is poor connections. Therefore, disconnecting, inspecting, and reconnecting wires will be necessary throughout test procedures.
- All tests/checks should be made with a VOM or DVM having a sensitivity of 20,000 ohms-per-volt DC, or greater.
- Check all connections before replacing components, look for broken or loose wires, failed terminals, or wires not pressed into connectors far enough.
- Voltage checks must be made with all connectors attached to the boards.
- Resistance checks must be made with power cord unplugged or power disconnected, and with wiring harness or connectors disconnected from the control.
- The testing procedures in this section may require the use of needle probes to measure voltage. Failure to use needle probes will damage the connectors.

ACU Diagnostic LED

Always check the LEDs before replacing it.

LED Slow Blinking	Normal ACU Operation.
	No unrecoverable ACU failures recorded.
	LED blinks 0.5 seconds ON / 0.5 seconds OFF
LED Solid ON	Power is applied to the ACU, but no setting file is present.
	Board is not functional in this state.
	Flash Setting File or replace ACU.
LED Double Blink	Communication failure between ACU and HMI.
	Check continuity between ACU and HMI.
LED Fast Blinking	ACU is performing initialization or ACU setting file is in progress of being programmed.
LED OFF	An unrecoverable ACU fault has been recorded or no power is applied to the ACU.
	Check for L1 voltage at P4 Pin 1.
	Check fault history.
LED Triple Blink	Incompatibility between ACU setting file and firmware.
	When applicable, use the service tool to re-flash setting file.

For Service Technician Use Only

Electronic Control Board

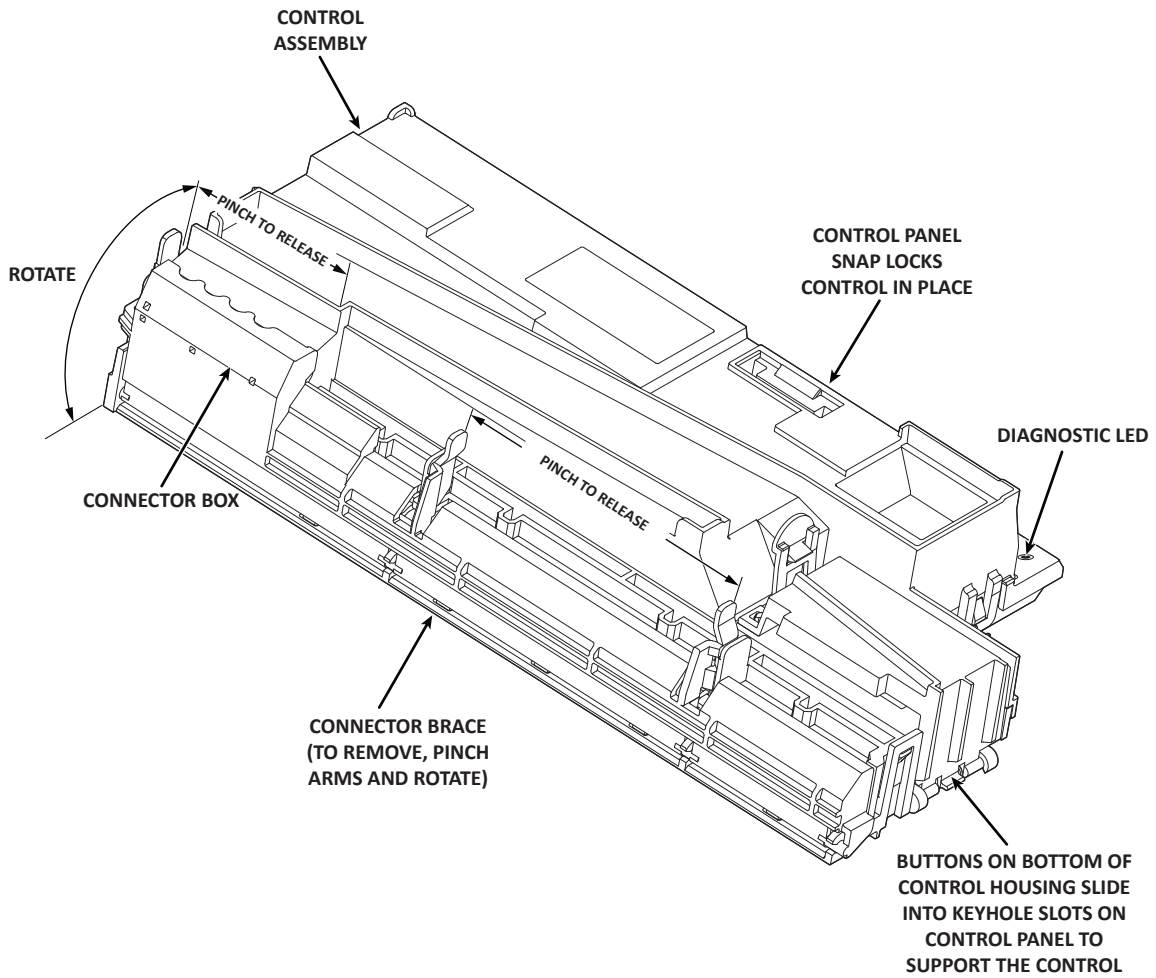

Meter Check of Loads and Supplies

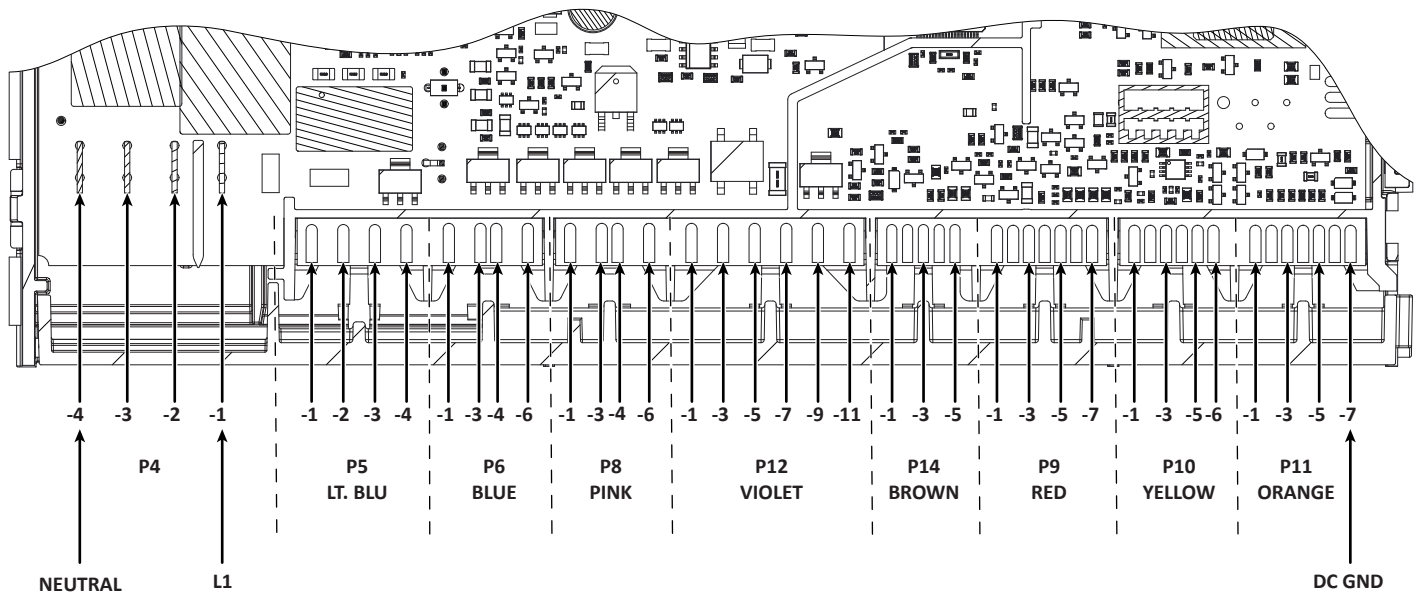

For Service Technician Use Only

General Theory of Operation

⚠ DANGER



Electrical Shock Hazard
Only authorized technicians should perform diagnostic voltage measurements.
After performing voltage measurements, disconnect power before servicing.
Failure to follow these instructions can result in death or electrical shock.

Refer to wiring diagram in tech-sheet provided with product.

Neutral and L1 (AC voltage) enters the Control Board at P4, pins 4 and 1 respectively. AC is converted to DC voltage at the Low Volts Power Supply (LVPS). Supplies include 13 VDC and 5 VDC, and DC GND (REF). These low voltage supplies are used to provide power to the microprocessors and board components, control the TRIAC, power the sensors, user interface, buzzer, fan motor, and energize the AC relays.

The 13 VDC is vital to the operation of the dishwasher. This supply is necessary to operate all 120 VAC loads in the dishwasher, whether they are connected to a relay or controlled by TRIAC. 13 VDC is generated by the power supply and flows through the door switch-when closed-to be available to the heater relays (L1 and N), wash motor relay, and the pilot relay. A relay coil becomes energized when the control closes the LV drive circuit for a specific relay completing 13 V pathway, which in turn closes the relay switch providing AC to the load. The Pilot relay provides “L1” to the remainder of the components that are controlled by the Neutral-sensed TRIAC.

In the micro-filtration dishwasher, there are 2 or 3 fuses on the Control Board: F500 Small TRIAC Load Fuse, F101 Main Power Supply Fuse, and F501 Wash Motor Fuse. If the TRIAC Fuse is open, all loads controlled by TRIAC will not operate. If the Main Power Supply Fuse is open, no 5 V or 13 V supply will be available and the unit will appear to not power up. If the Wash Motor Fuse (optional) is open, all loads will work except the wash motor.

NOTE: Refer to “Fuse Service and Diagnostic Checks” on page [3-4](#).

Power Check

This test checks for incoming and outgoing power to and from the control board. This test assumes that proper voltages is present at the outlet or direct connect cable.

Test Procedure

1. Unplug dishwasher or disconnect power.
 2. Remove access panel.
 3. Remove terminal box cover.
 4. With a voltmeter set to AC, place black probe on white terminal block screw head (N) and red probe on black terminal block screw head (L1).
 5. Plug in dishwasher or reconnect power.
 - If 120 VAC is present, unplug dishwasher or disconnect power and proceed to step 6.
 - If 120 VAC is not present, have customer correct power.
 6. Remove the outer door panel to access the control board.
 7. Remove cover from control board and locate connector P4.
 8. With a voltmeter set to AC, connect black probe to P4, pin 4 (N) and red probe to P4, pin 1 (L1).
 9. Plug in dishwasher or reconnect power.
 - If 120 VAC is present, go to step 10.
 - If 120 VAC is not present, check for open connection between terminal block and control. Repair as needed.
 10. Verify DC Supplies.
 - 5 VDC is used to power IC's and micro-processors on the circuit board as well as provide power to the sensors.
 - If 5 VDC were missing, the OWI (Optical Water Indicator) and user interface would not function. To verify 5 V \pm 5%, with a voltmeter set to DC, connect the black lead to P10-2 (DC GND) and the red lead to P11A-2 or P11B-2 (5 V).
 - 13 VDC is used to actuate the 120 VAC relays and TRIAC on the control, the overflow switch input, and the LEDs on models with interior lighting.
 - If 13 VDC was missing, the heater, motors, and all the other loads would not turn on as well as the LEDs on models with interior lighting. The control would falsely detect an overflow fault. To verify 13 V \pm 5%, with a voltmeter set to DC, connect the black lead to P10-2 (DC GND) and the red lead to P11-7 (13 V).
- Troubleshooting Missing DC Supplies:** Refer to the wiring diagram in tech-sheet provided with product when troubleshooting the DC supplies. If 5 VDC or 13 VDC is missing on the control, unplug dishwasher or disconnect power, and then disconnect all components/loads from the control relying on the missing or loaded supply. Plug in dishwasher or reconnect power and check if the DC supply has returned.
- If not, replace the control.
 - If it has, turn off dishwasher and reconnect one connector at a time until the component loading down that supply has been identified.
11. Unplug dishwasher or disconnect power.
 12. Reassemble all parts and panels.

For Service Technician Use Only

⚠ DANGER



Electrical Shock Hazard

Only authorized technicians should perform diagnostic voltage measurements.

After performing voltage measurements, disconnect power before servicing.

Failure to follow these instructions can result in death or electrical shock.

Door Switch Circuit

Perform the following checks if the dishwasher does not detect the door open or closed. This test will check the wiring to the door switch and the door switch itself. The following items are part of the door switch circuit:

- Harness/Connection
- Door Switch/Latch Assembly
- Control Board

Test Procedure

1. Check for improper installation of the dishwasher or leveling.
2. Check door latch mechanism for obstructions or binding. Verify door seal is seated properly.
3. Check for interference between dish racks and door. Repair as necessary.
4. Unplug dishwasher or disconnect power.
5. Remove outer door panel to access door latch and remove toe and access panels to access control board.

6. Check door switch contacts and all connections in the door switch circuit. Visually check that the P12 connector on the control and the door latch connector are securely installed.
 - If visual check passes, go to step 5.
 - If any of the connectors are not inserted properly, reconnect and retest door latch/switch.
7. Disconnect connector P12 from the control board.
8. Using an ohmmeter, measure across P12, pins 9 and 11 with the door closed, strike completely in latch mechanism (switch closed).
 - If 3Ω or less is measured, proceed to step 7.
 - If high resistance is measured when door is closed, check for loose connections and repair as needed.
9. Using an ohmmeter, measure across P12, pins 9 and 11 with the door open, strike removed from latch mechanism (switch open).
 - If reading is infinite, go to step 8.
 - If reading shows continuity, or door switch is damaged, replace door switch and retest.
10. Set voltmeter to DC and connect red lead to test-pad P11-7 (13 V) and black lead to P10-2 (DC GND) on the control board.
11. Plug in dishwasher or reconnect power and with door open, verify that 13 VDC is present across P11-7 and P10-2.
 - If 13 VDC is not present, replace the control and retest.
 - If 13 VDC is present, proceed to step 10.
12. Reconnect P12 to control board and perform Diagnostics Cycle to verify operation.
13. Unplug dishwasher or disconnect power.
14. Reassemble all parts and panels.
15. Plug in dishwasher or reconnect power.

Strip Circuit - Door Switch

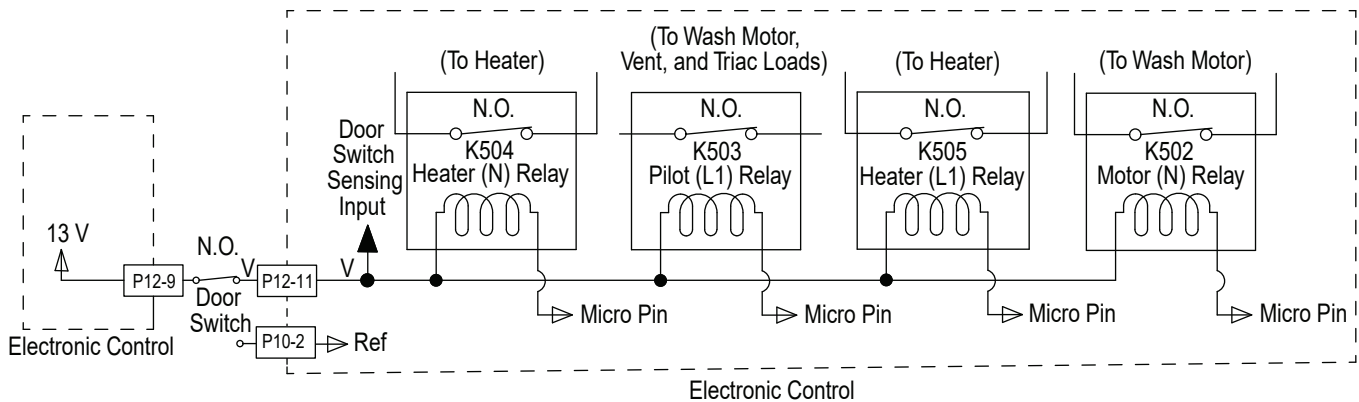

For Service Technician Use Only

⚠ DANGER



Electrical Shock Hazard

Only authorized technicians should perform diagnostic voltage measurements.

After performing voltage measurements, disconnect power before servicing.

Failure to follow these instructions can result in death or electrical shock.

6. Check the fill valve and harness-using an ohmmeter, measure the resistance between P6-1 and P6-3.
 - If the resistance is between 1200-1600 Ω, the fill valve and harness are good. Go to step 7.
 - If outside the range, replace the fill valve.
 - If an open circuit is detected, check connections and harness continuity between control and fill valve. If good, replace the fill valve.
 7. Reconnect P6 to control board.
 8. Set voltmeter to AC and connect leads to test-pads P6-1 and P6-3 on the control board. Plug in dishwasher or reconnect power.
 9. Start the Diagnostics Cycle and at the proper interval measure for AC out of the control board between test-pads P6- 1 and P6-3 (Refer to the Fill Valve Strip Circuit below).
- IMPORTANT:** The Fill Valve must be connected to the control board to measure voltage accurately.
- If no AC voltage is measured, replace the control board and retest.
 - If 120 VAC is measured and fill valve is energized, go to step 12.
10. Unplug dishwasher or disconnect power.
 11. Reassemble all parts and panels.
 12. Plug in dishwasher or reconnect power and run Diagnostics Cycle to verify repair.

Fill Circuit

This test will check the wiring and components in the fill circuit. The following items are part of the fill circuit:

- Harness/Connection
- Fill Valve
- Control Board

Test Procedure

1. Verify water supply is turned on and supply line is adequate. Check for water siphoning out of the dishwasher (drain loop or improper drain connection). Check for debris in water line or fill valve inlet screen. Check for proper float switch operation. Repair as necessary.
2. Are all the loads controlled by TRIAC not working?
 - YES - check for open door switch, TRIAC fuse, or pilot relay.
 - NO - just the Fill Valve. Go to step 3.
3. Unplug dishwasher or disconnect power.
4. Remove toe and outer door panels to access control board.
5. Unplug connector P6 from control board.

Strip Circuit - Fill Valve

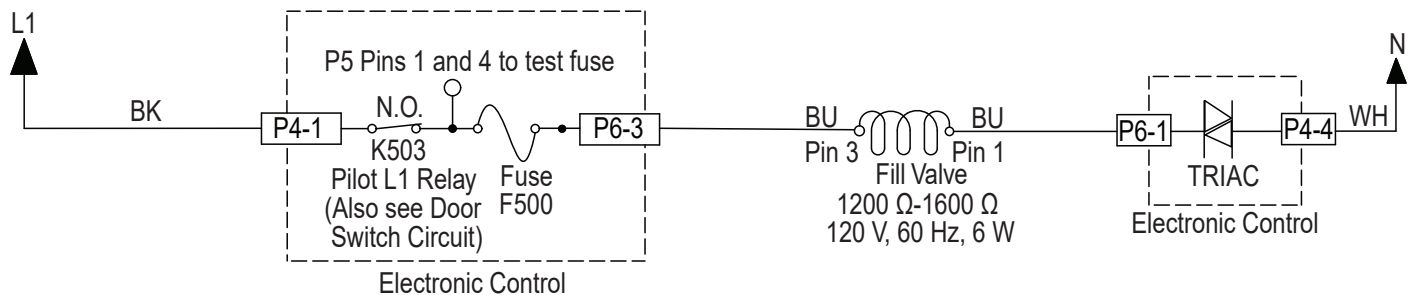

For Service Technician Use Only

⚠ DANGER



Electrical Shock Hazard

Only authorized technicians should perform diagnostic voltage measurements.

After performing voltage measurements, disconnect power before servicing.

Failure to follow these instructions can result in death or electrical shock.

6. Check the dispenser solenoid and harness-using an ohmmeter, measure the resistance between P12-5 and P12-7.

Solenoid:

- If the resistance is between 310-380 Ω, the solenoid valve and harness are good. Go to step 7.
 - If outside the range, replace the dispenser solenoid.
 - If an open circuit is detected, check connections and harness continuity between control and dispenser. If good, replace the dispenser solenoid.
7. Reconnect P12 to control board.
 8. Set voltmeter to AC and connect leads to test-pads P12-5 and P12-7 on the control board. Plug in dishwasher or reconnect power.
 9. Start the Diagnostics Cycle and at the proper interval measure for AC out of the control board between P12-5 to P12-7 (Refer to the Dispenser Strip Circuit below).

IMPORTANT: The Dispenser Solenoid must be connected to the control board to measure voltage accurately.

 - If no AC voltage is measured, replace the control board and retest.
 - If 120 VAC is measured and dispenser motor/solenoid is energized, go to step 10.
 10. Unplug dishwasher or disconnect power.
 11. Reassemble all parts and panels.
 12. Plug in dishwasher or reconnect power and run Diagnostics Cycle to verify repair.

Dispenser Circuit

This test will check the wiring to the dispenser and the dispenser solenoid itself. The following items are part of the dispenser circuit:

- Harness/Connection
- Dispenser Solenoid
- Control Board

Test Procedure

1. Check for obstructions or mechanical binding preventing the dispenser lid from opening. Repair or replace as necessary.
2. Are all the loads controlled by TRIAC not working?
 - YES - check for open door switch, TRIAC fuse, or pilot relay.
 - NO - just the Dispenser. Go to step 3.
3. Unplug dishwasher or disconnect power.
4. Remove outer door panel to access dispenser and remove toe and outer door panels to access control board.
5. Unplug connector P12 from control board.

Strip Circuit - Dispenser

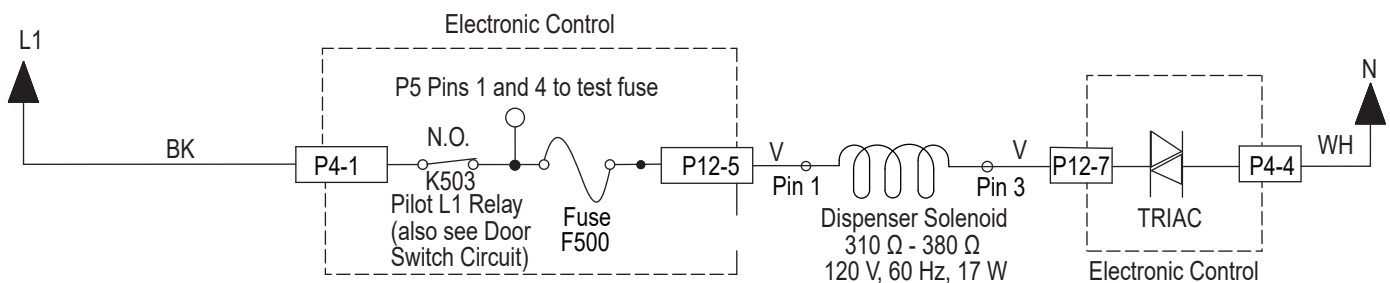

For Service Technician Use Only

⚠ DANGER



Electrical Shock Hazard

Only authorized technicians should perform diagnostic voltage measurements.

After performing voltage measurements, disconnect power before servicing.

Failure to follow these instructions can result in death or electrical shock.

4. Using an ohmmeter, measure resistance between P4, pins 2 and 3.
 - If the resistance is between 10-40 Ω, go to step 6.
 - If an open circuit is detected, go to step 5.
5. Visually check the wire connections between the control board, the heater element and the hi-limit thermostat. If the connections look good, check for continuity across the heater element and the hi-limit.
 - Replace heater element or hi-limit thermostat if it is electrically open.
 - Repair or replace wire harness if test fails continuity.
6. Reconnect P4 to control board.
7. Set voltmeter to AC and connect leads to test-pads P4-2 and P4-3 on the control board. Plug in dishwasher or reconnect power.
8. Start the Diagnostics Cycle and at the proper interval measure for AC out of the control board between P4-2 and P4-3 using a voltmeter set to AC.
 - If 120 VAC is measured and heater element is on, go to step 9.
 - If no AC voltage is measured, replace control board.
9. Perform Diagnostics Cycle to verify repair.
 - If heater related error still exists, perform Water Sensing test procedure on following page.
10. Unplug dishwasher or disconnect power.
11. Reassemble all parts and panels.
12. Plug in dishwasher or reconnect power.

Water Heating/Heat Dry

This test will check the wiring to the heater element, hi-limit thermostat and the heating circuit itself. The following items are part of the heater circuit:

- Harness/Connection
- Heater Coil
- Hi Limit Thermostat
- Control Board

Test Procedure

Control is programmed to disable the heater if it detects a problem with the heating system. This check is performed at the start of a heating period in each cycle. If heating problem is not corrected, the control will disable the heater again.

1. Unplug dishwasher or disconnect power.
2. Remove toe and access panels to outer door control board.
3. Disconnect P4 from the control board.

Strip Circuit - Heater Circuit

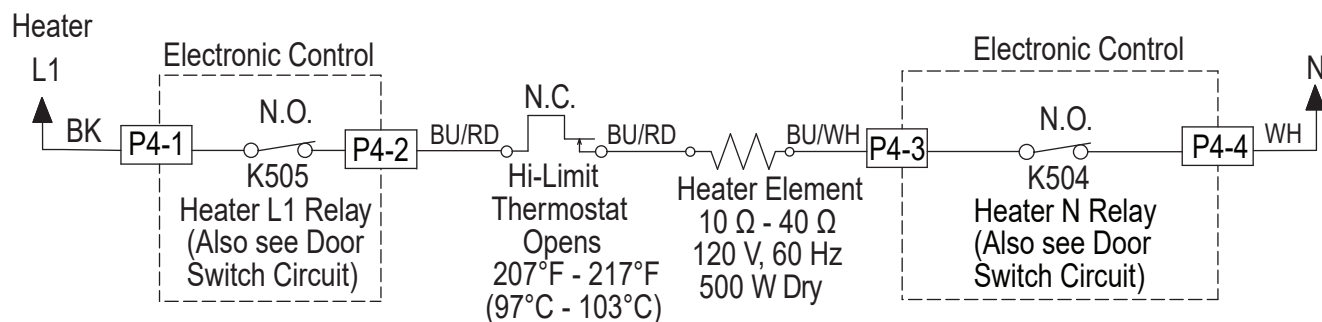

For Service Technician Use Only

⚠ DANGER



Electrical Shock Hazard

Only authorized technicians should perform diagnostic voltage measurements.

After performing voltage measurements, disconnect power before servicing.

Failure to follow these instructions can result in death or electrical shock.

Temp °C (°F)	RES Range (kΩ)
40 (104)	24.6 - 25.4
45 (113)	20.2 - 20.8
50 (122)	16.7 - 17.1
55 (131)	13.9 - 14.2
60 (140)	11.6 - 11.8
65 (149)	9.7 - 9.9
70 (158)	8.2 - 8.4

NOTE: All thermistor resistance measurements must be made while dishwasher is unplugged or disconnected from power and connector P10 removed from control.

- If the thermistor resistance is OK , the thermistor is good. Go to step 6.
 - If the thermistor resistance does not agree with the table, replace the OWI Sensor.
 - If an open circuit is detected, check connections and harness continuity between control and OWI. If good, replace the OWI Sensor.
6. Using an ohmmeter, check P10 -1 to cabinet ground and P10-3 to cabinet ground.
 - If no short is indicated, go to step 7.
 - If either pin indicates continuity to ground (short), repair or replace wiring harness and retest.
 7. Reconnect P10 to control board.
 8. Test for 5 VDC with a voltmeter set to DC, connect the black lead to P10-2 and the red lead to P10-3.
 9. Plug in dishwasher or reconnect power.
 10. Start the Diagnostics Cycle and at the proper interval measure for 5 VDC out of the control board between P10-2 and P10-3.
 - If 5 VDC is measured the control is functioning, go to step 11.
 - If no DC voltage is measured, replace the control board and retest.
 11. Unplug dishwasher or disconnect power.
 12. Reassemble all parts and panels.
 13. Plug in dishwasher or reconnect power and run Diagnostics Cycle to verify repair.

Water Sensing with the OWI Sensor

This test will check the wiring to the OWI (Optical Water Indicator), which incorporates the temperature thermistor and the foam and turbidity sensor. The following items are part of the water sensing circuit:

- Harness/Connection
- OWI Sensor
- Control Board

Test Procedure

1. Check the operation of the OWI Sensor in the Service Diagnostics Cycle.
2. Unplug dishwasher or disconnect power.
3. Remove toe and access panels to access control board.
4. Disconnect P10 from the Control Board.
5. Using an ohmmeter, measure resistance between P10, pins 1 and 3. The following table provides approximate room and hot water temperatures and their associated resistance values.

Temp °C (°F)	RES Range (kΩ)
20 (68)	57.3 - 60.3
25 (77)	45.9 - 48.1
30 (86)	37.0 - 38.7
35 (95)	30.1 - 31.3

Strip Circuit - Water Sensing

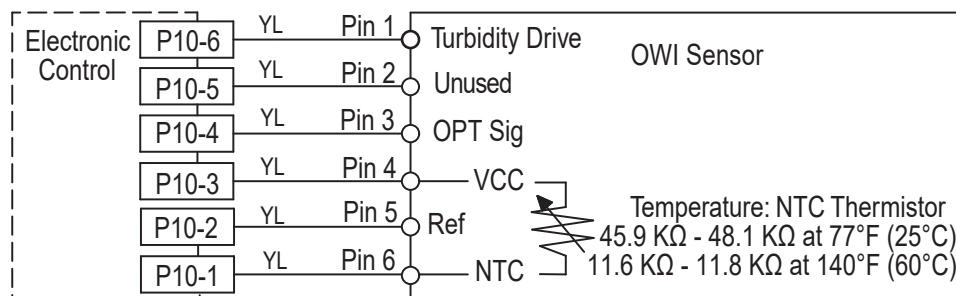

Measure NTC resistance at P10-1 and P10-3 connector disconnected from control.

For Service Technician Use Only

⚠ DANGER



Electrical Shock Hazard

Only authorized technicians should perform diagnostic voltage measurements.

After performing voltage measurements, disconnect power before servicing.

Failure to follow these instructions can result in death or electrical shock.

5. Inspect float assembly. Verify that connector is fully seated. Ensure that Styrofoam floater moves freely up and down and no debris is preventing it from sitting in the down (closed) position.
 - If no issue found, go to step 6.
 - Repair/reconnect if any issues found.
6. Disconnect connector P11 from control board.
7. Using an Ohmmeter, measure across P11 pins 6 and 7 with the float assembly connected and installed in the leak pan.
 - If 3 Ω or less is measured, go to step 8.
 - If high resistance is measured, check for loose connections and repair/replace as needed.
8. Using an Ohmmeter, measure across P11 pins 6 and 7 with the Styrofoam floater lifted up (switch should be open).
 - If reading is infinite, go to step 9.
 - If reading shows continuity, replace float assembly and retest.
9. Set meter to DC and connect leads to P11 pins 6 and 7.
10. Plug in dishwasher or reconnect power and verify that 13 VDC is present across P11 pins 6 and 7 with P11 disconnected from the board.
 - If 13 VDC is not present, replace the control and retest.
 - If 13 VDC is present, proceed to step 10.
11. Reconnect P11 to control board and run Diagnostics cycle to confirm operation.
12. Reassemble all parts and panels. Ensure that float assembly is connected, seated in leak tray, and tray is reinstalled.
13. Plug in dishwasher or reconnect power.

Overfill Switch Circuit

Perform the following checks if the dishwasher detects F8E4 when there is no water in the leak pan, or if F8E4 is not detected when water is present in the leak pan. The following items are part of the overfill switch circuit:

- Harness/Connection
- Overfill Switch/Float Assembly
- Control Board

Test Procedure

1. Unplug dishwasher or disconnect power.
2. Remove toe and outer door panels to access leak pan and control board.
3. Check leak pan for water. If no water is present, go to step 5. If leak pan is full of water, unplug float switch, remove pan and empty. Replace pan and reconnect float switch.
4. Reconnect power. If F8E4 fault does not return, find source of leak and repair.

NOTE: If root cause of overfill is not corrected, customer will experience another overfill and service call in the future.

Strip Circuit - Overfill Switch

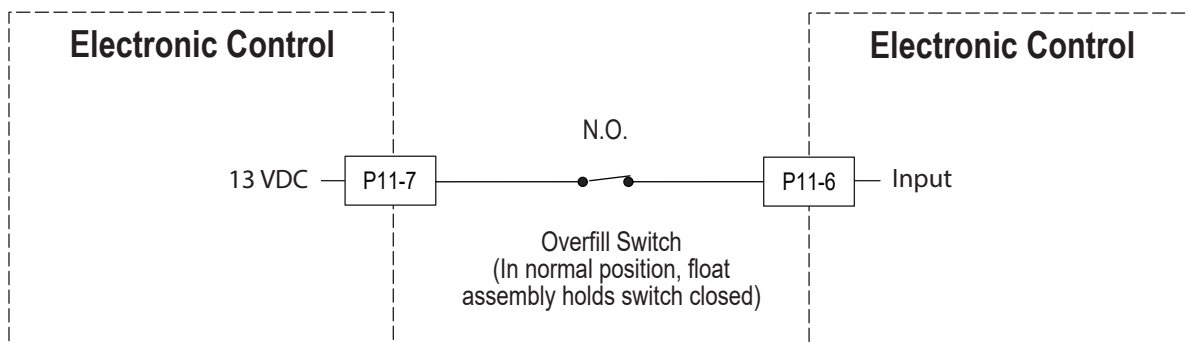

For Service Technician Use Only

⚠ DANGER



Electrical Shock Hazard

Only authorized technicians should perform diagnostic voltage measurements.

After performing voltage measurements, disconnect power before servicing.

Failure to follow these instructions can result in death or electrical shock.

Diverter Motor

This test will check the wiring to the diverter motor and the diverter motor itself. The following items are part of the diverter motor circuit:

- Harness/Connection
- Diverter Motor
- Diverter Position Switch (see test on following page)
- Control Board

Test Procedure

1. Check for operation in Diagnostics Cycle. Listen for water spray changing zones or inspect shaft with mirror to see it rotating during diverter interval. If diverter is rotating, the likely problem is with the diverter sensor (see test procedure on following page). Verify that diverter disk is properly installed on shaft.
2. Are all the loads controlled by TRIAC not working?
 - YES - check for open door switch, TRIAC fuse, or pilot relay.
 - NO - just the diverter valve. Go to step 3.

3. Unplug dishwasher or disconnect power.
4. Remove toe and access panels to access control board.
5. Unplug connector P6 from control board.
6. Check the diverter motor using an ohmmeter, measure the resistance between P6-4 and P6-6.
 - If the resistance is between 1100-1400 Ω , the diverter motor and harness are good. Go to step 7.
 - If outside the range, replace the diverter assembly.
 - If an open circuit is detected, check connections and harness continuity between control and diverter assembly. If good, replace the diverter assembly.
7. Reconnect P6 to control board.
8. Set voltmeter to AC and connect leads to test-pads P6-4 and P6-6 on the control board. Plug in dishwasher or reconnect power.
9. Start the Diagnostics Cycle and at the proper interval measure for AC out of the control board between P6-4 and P6-6 (Refer to Diverter Motor Strip Circuit below).

IMPORTANT: The Diverter Motor must be connected to the control board to measure voltage accurately.

 - If no AC voltage is measured, replace the control board and retest.
 - If 120 VAC is measured and diverter is rotating, go to step 10.
10. Perform Diagnostics Cycle to verify repair.
 - If diverter error still exists, perform diverter sensor test procedure on following page.
11. Unplug dishwasher or disconnect power.
12. Reassemble all parts and panels.
13. Plug in dishwasher or reconnect power.

Strip Circuit - Diverter Motor

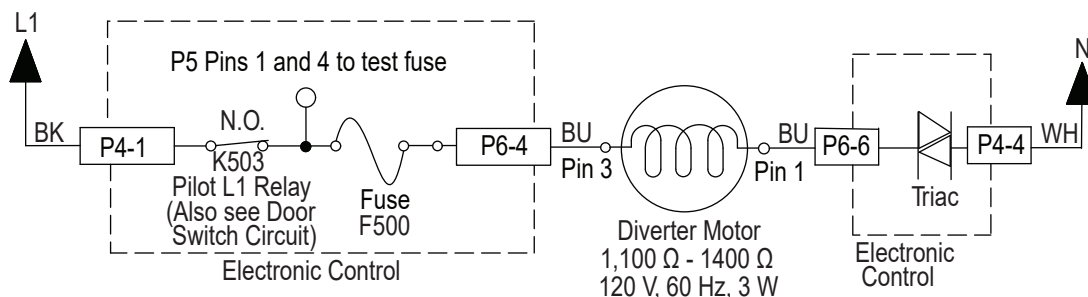

For Service Technician Use Only

⚠ DANGER



Electrical Shock Hazard

Only authorized technicians should perform diagnostic voltage measurements.

After performing voltage measurements, disconnect power before servicing.

Failure to follow these instructions can result in death or electrical shock.

3. Unplug dishwasher or disconnect power.
4. Remove toe and outer door panels to access control board.
5. Visually check that the diverter position switch connector and P11 connector on the control are securely installed.
 - If visual check passes, go to step 6.
 - If any of the connectors are not inserted properly, reconnect and retest diverter position switch.
6. Check continuity of harness between diverter position switch and P11 on control.
 - If continuity test is good, continue to step 7.
 - If continuity test fails, repair or replace harness as needed.
7. To test diverter switch, set up voltmeter for DC voltage and connect red lead to P11-2 and black lead to P10-2.
8. Plug in dishwasher or reconnect power.
9. Run the Service Diagnostics Cycle as stated in Step 1, and you should observe the diverter position switch closing momentarily and then reopening as it reaches each potential position. DC voltage should vary from approximately 0 V to 8-10 V as the diverter rotates and the sensor detects positions. Monitor for several intervals of the Service Diagnostics Cycle to observe behavior.
 - If the sensor is functioning normally (Voltage is varying as diverter rotates), proceed to step 10.
 - If sensor does not detect positions properly, or voltage is consistently at 0 V or 8-10 V and does not change, then replace diverter assembly and retest.
10. If the preceding steps did not correct the diverter/position switch problem, replace the control board and retest.
11. Reassemble all parts and panels.
12. Plug in dishwasher or reconnect power and run Diagnostics Cycle to verify repair.

Diverter Position Optical Sensor

This test will check the wiring to the diverter sensor/position sensor and the diverter assembly itself. The following items are part of the diverter sensor/switch circuit:

- Harness/Connection
- Diverter Motor (see test on previous page)
- Diverter Position Optical Sensor
- Control Board

Test Procedure

1. Check the operation of the diverter motor in the Service Diagnostics Cycle. You should be able to “hear” the water spraying from different spray arms as the diverter rotates through the various wash zones.
2. If the diverter is diverting the flow of water to the wash zones, the diverter motor is working-continue to step 3. If not, perform the diverter motor test procedure on the preceding page.

Strip Circuit - Diverter Switch

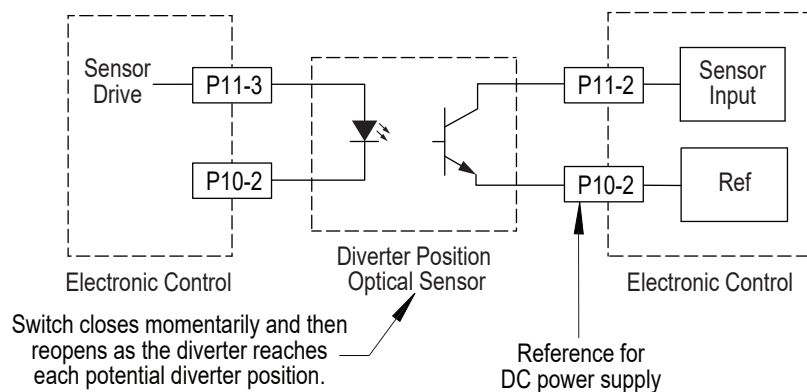

For Service Technician Use Only

⚠ DANGER



Electrical Shock Hazard

Only authorized technicians should perform diagnostic voltage measurements.

After performing voltage measurements, disconnect power before servicing.

Failure to follow these instructions can result in death or electrical shock.

Wash Motor

This test will check the wiring to the wash motor and the wash motor itself. The following items are part of the wash motor circuit:

- Harness/Connection
- Wash Motor and Capacitor
- Control Board
- Wash motor fuse (Some models)

Test Procedure

1. Check the tube and sump for anything that may be impeding water flow. Inspect and if necessary clean the coarse-filter system. Also, inspect spray arm water nozzles and clean if needed.
2. Check the wash motor and electrical connections by performing the Service Diagnostics Cycle. The following steps assume that this step was unsuccessful.
3. Unplug dishwasher or disconnect power.
4. Remove toe and outer door panels to access control board.
5. Unplug connector P5 from control board.
6. Check the wash motor using an ohmmeter, measure the resistance between P5-1 and P5-2.

Strip Circuit - Wash Motor

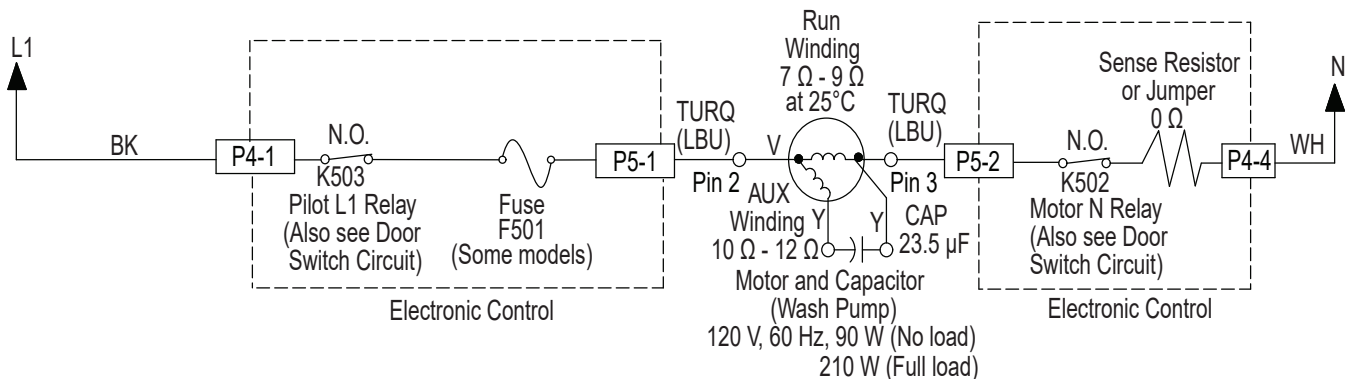

- If the resistance is between $10\text{-}15\ \Omega$, the wash motor and harness are good. Go to step 7.
 - If outside the range, replace the wash motor.
 - If an open circuit is detected, check connections and harness continuity between control and wash motor. If good, replace the wash motor.
7. Check the motor fuse (Some models). Using an ohmmeter, measure the resistance between P4-1 and P5-1 on the control.
 - If the resistance is less than $3\ \Omega$, fuse is good. Go to step 8.
 - If the resistance is greater than $3\ \Omega$, replace the control.
 8. Reconnect P5 to control board.
 9. Set voltmeter to AC and connect leads to test-pads
 10. P5-1 and P5-2 on the control board. Plug in dishwasher or reconnect power.
 11. Start the Diagnostics Cycle and at the proper interval measure for AC out of the control board between P5-1 and P5-2 (Refer to Wash Motor Strip Circuit below).
 - If no AC voltage is measured, replace the control board and retest.
 - If 120 VAC is measured and wash motor is running, go to step 12.
 - If 120 VAC is measured and wash motor is not running, go to step 10.
 12. Test the wash motor capacitor.

NOTE: A faulty capacitor may cause the motor to “hum”, not start, or start slowly.

 - A. Discharge the capacitor by touching the leads of a $20,000\ \Omega$ resistor to the two terminals.
 - B. Disconnect the wires from the capacitor terminals.
 - C. With an ohmmeter, measure across the terminals and note reading.
 - If a steady increase in resistance is noted, capacitor is good. Replace wash motor assembly and retest.
 - If the capacitor is either shorted or open, replace capacitor and retest.
 - If the preceding steps did not correct the wash motor problem, replace the control board.
 13. Unplug dishwasher or disconnect power.
 14. Reassemble all parts and panels.
 15. Plug in dishwasher or reconnect power and run Diagnostics Cycle to verify repair.

For Service Technician Use Only

Soil buildup on the RIF filter can cause F9E1 drain pump not the issue. In those cases there was not water left in the tub. Check the following things:

- Pinched drain hose and/or hose routing
- Wire off
- Old hose is blocked somewhere in the line.
- If none of those, then remove the drain pump and check for axial play.
- If the axial play is fine, also check for motor short or open.
- Blocked knock-out port in a new garbage disposal
- Food soil buildup in the pump housing (see error code F7E4)

2. Check the drain motor and electrical connections by performing the Service Diagnostics Cycle. The following steps assume that this step was unsuccessful.
3. Are all the loads controlled by TRIAC not working?
 - YES - check for open door switch, TRIAC fuse, or pilot relay.
 - NO - just the drain motor. Go to step 4.
4. Unplug dishwasher or disconnect power.
5. Remove toe and outer door panels to access control board.
6. Unplug connector P5 from control board.
7. Check the drain motor using an ohmmeter, measure the resistance between P5-3 and P5-4.
 - If the resistance is between 27-33 Ω , the drain motor and harness are good. Go to step 8.
 - If outside the range, replace the drain motor.
 - If an open circuit is detected, check connections and harness continuity between control and drain motor. If good, replace the drain motor.
8. Reconnect P5 to control board.
9. Set voltmeter to AC and connect leads to test-pads P5-3 and P5-4 on the control board. Plug in dishwasher or reconnect power.
10. Start the Diagnostics Cycle and at the proper interval measure for AC out of the control board between P5-3 and P5-4 (Refer to Drain Motor Strip Circuit below).

IMPORTANT: The Drain Motor must be connected to the control board to measure voltage accurately.

 - If no AC voltage is measured, replace the control board and retest.
 - If 120 VAC is measured and drain motor is running, go to step 11.
11. Unplug dishwasher or disconnect power.
12. Reassemble all parts and panels.
13. Plug in dishwasher or reconnect power and run Diagnostics Cycle to verify repair.

The drain pump motor may experience an intermittent instance to lock up. In many cases, the pump cools down and will operate again.

For intermittent pump locking, check the following:

- Resistance provided in specification.
- Harness wiring to the pump for continuity.
- Voltage at the pump.
- Then remove the drain pump and check for axial play. If the axial play is fine, also check for motor short or open.
- If all checks are acceptable, change the pump to assume that it has the rare intermittent instance.
- Replacement parts are not likely to have the same condition.

⚠ DANGER



Electrical Shock Hazard

Only authorized technicians should perform diagnostic voltage measurements.

After performing voltage measurements, disconnect power before servicing.

Failure to follow these instructions can result in death or electrical shock.

Drain Motor

This test will check the wiring to the drain motor and the drain motor itself. The following items are part of the drain motor circuit:

- Harness/Connection
- Drain Motor
- Control Board

Test Procedure

1. Verify that drain hose or drain path is not obstructed. Check for blockage from sump check valve to customer's plumbing. Check for plugged garbage disposal or disposal plug not knocked out. Check drain loop, stuck check valve, or for plugged hoses. Repair as needed.

Strip Circuit - Drain Motor

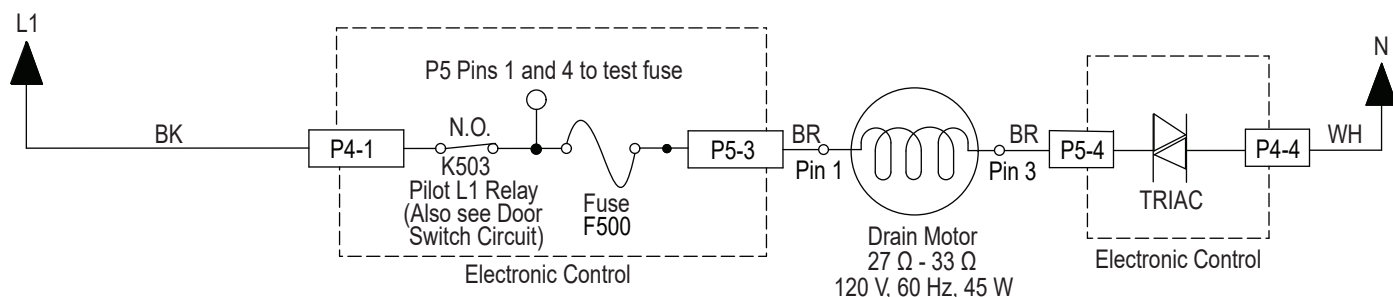

For Service Technician Use Only

⚠ DANGER



Electrical Shock Hazard

Only authorized technicians should perform diagnostic voltage measurements.

After performing voltage measurements, disconnect power before servicing.

Failure to follow these instructions can result in death or electrical shock.

4. Unplug connector P14 from control board.
5. Check the fan motor using an ohmmeter, measure the resistance between P14-1 and P14-2.
 - If the resistance is between 145-185 kΩ , the fan motor and harness are good. Go to step 7.
 - If outside the range, replace the fan motor assembly.
 - If an open circuit is detected, check connections and harness continuity between control and fan motor. If good, replace the fan motor assembly.
6. Reconnect P14 to control board.
7. Set voltmeter to DC and connect leads to test-pads P14- 1 and P14-2 on the control board. Plug in dishwasher or reconnect power.
8. Start the Diagnostics Cycle and at the proper interval measure for DC out of the control board between P14-1 and P14-2 (Refer to DC Fan Motor Strip Circuit below).

IMPORTANT: The Fan Motor must be connected to the control board to measure voltage accurately!

 - If no DC voltage is measured, replace the control board and retest.
 - If 13 VDC ± 5% is measured and the fan is spinning, go to step 9.
9. Unplug dishwasher or disconnect power.
10. Reassemble all parts and panels.
11. Plug in dishwasher or reconnect power and run Diagnostics Cycle to verify repair.

DC Fan Motor

This test will check the wiring to the DC fan motor and the fan motor itself. The following items are part of the DC Fan Motor circuit:

- Harness/Connection
- DC Fan Motor
- Control Board

Test Procedure

1. Check for fan operation in the Diagnostics Cycle. The DC fan should be running during step 4.
2. Unplug dishwasher or disconnect power.
3. Remove toe and outer door panels to access control board.

Strip Circuit - DC Fan Motor

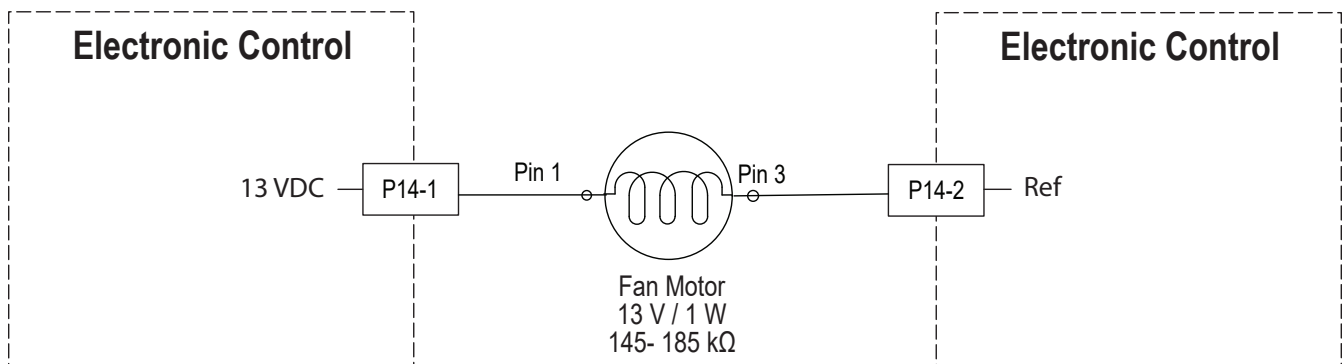

For Service Technician Use Only

⚠ DANGER



Electrical Shock Hazard

Only authorized technicians should perform diagnostic voltage measurements.

After performing voltage measurements, disconnect power before servicing.

Failure to follow these instructions can result in death or electrical shock.

Interior LED Lighting (some models)

This test will check the wiring to the LED tube lights and the lights themselves. The following items are part of the LED Tube Lights circuit:

- Harness/Connection
- LED Tube-lights (2)
- Control Board

Under normal operation

- The Interior LED Lighting is not on during the wash cycle.
- The Interior LED Lighting turns on when the door is opened and remains on for 10 minutes.

Test Procedure

NOTE: The two (2) LED Tube-lights are wired in parallel. It is possible for one light to malfunction and the other to remain operational.

Strip Circuit - Interior LED Lighting

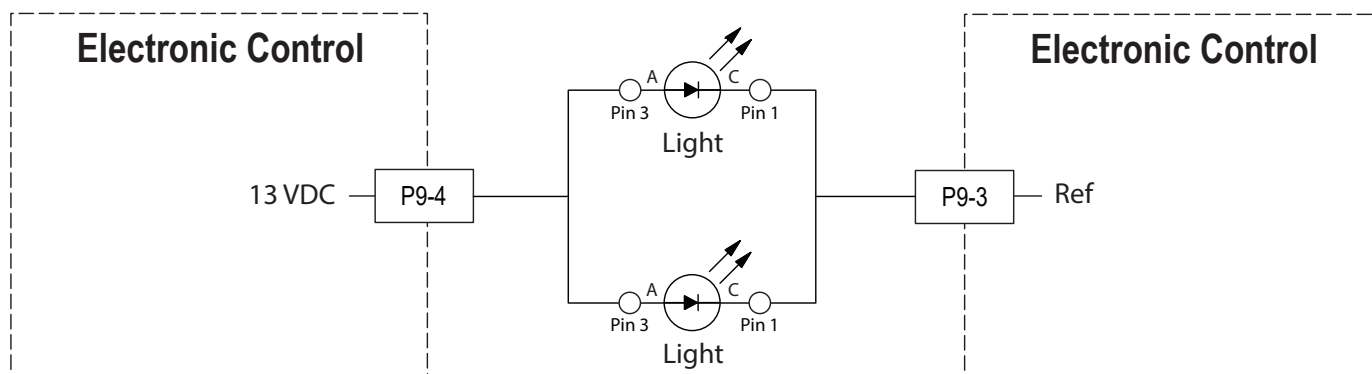

1. Open dishwasher door. The Interior LED Lights should turn on. The following steps assume that this step was unsuccessful.
2. Unplug dishwasher or disconnect power.
3. Remove toe and outer door panels to access control board.
4. Visually check that the P9 connector on the control is securely installed.
 - If visual passes, go to step 5.
 - If the connector is not inserted properly, reconnect and retest Interior LED Lighting.
5. Disconnect P9 from the Control Board.
6. Measure each LED light individually using the diode check setting on the multimeter. Meter should display a numeric reading from anode to cathode and "OL" reading from cathode to anode (refer to strip circuit below).
 - If LED check passes, go to step 7.
 - If any of the LEDs do not pass the check, replace the defective LED individually and retest Interior LED lighting.
7. Set voltmeter to DC and connect red lead to P9-3 and black lead to P9-4 on the control board. Plug in dishwasher or reconnect power.
8. Measure for 13 VDC between P9-2 and P9-4 with lights disconnected and door opened. Light output must be measured within 10 minutes of opening the door.
 - If 13 VDC is not present, replace the control and retest.
 - If 13 VDC is present, proceed to step 9.
9. Unplug dishwasher and disconnect power.
10. Reassemble all parts and panels.
11. Plug in dishwasher or reconnect power.

For Service Technician Use Only

⚠ DANGER



Electrical Shock Hazard

Only authorized technicians should perform diagnostic voltage measurements.

After performing voltage measurements, disconnect power before servicing.

Failure to follow these instructions can result in death or electrical shock.

ACU Diagnostic LED

Always check the LED's before replacing it.

The control is equipped with a single LED which is intended to help diagnose if the ACU needs to be replaced. The LED has different display patterns which indicate different states.

LED Slow Blinking: Normal ACU operation. No unrecoverable ACU fault has been recorded. LED blinks 0.5 seconds ON/ 0.5 seconds OFF.

LED Solid ON: Power is applied to ACU, but no Setting File has been programmed. Board is not functional in this state. Flash Setting File or replace ACU.

LED Double Blink: Communication failure between ACU and HMI. Check continuity between ACU and HMI.

LED Fast Blink: ACU is performing initialization or ACU setting file is in progress of being programmed.

LED OFF: An unrecoverable ACU fault has been recorded or no power is applied to the ACU. Check for L1 voltage at P4 Pin 1. Check fault history.

LED Triple Blink: Incompatibility between ACU setting file and firmware. When applicable, use the service tool to re-flash setting file.

User Interface (UI)

This test will check the wiring to the user interface and the user interface itself. The following items are part of the user interface circuit:

- Harness/Connection
- User Interface (UI)
- Status LED (On some models)
- Control Board

Test Procedure

1. Verify that the control lock-out feature has not been turned on by the customer. If unit will not run or power up, perform Power Check procedure. Also, check for excessive condensation on UI parts due to vent and/or fan problem.
2. Unplug dishwasher or disconnect power.
3. Remove toe and outer door panels to access control board.
4. Disconnect user interface connection from control board. Verify all other connections to the control are good.
5. Plug in dishwasher or reconnect power.
6. Perform DC power supply voltage checks as described above in "[General Theory of Operation](#)" section.
7. Repair/replace faulty parts.
8. Unplug dishwasher or disconnect power.
9. Reassemble all parts and panels.
10. Plug in dishwasher or reconnect power.

For Service Technician Use Only

Component Location

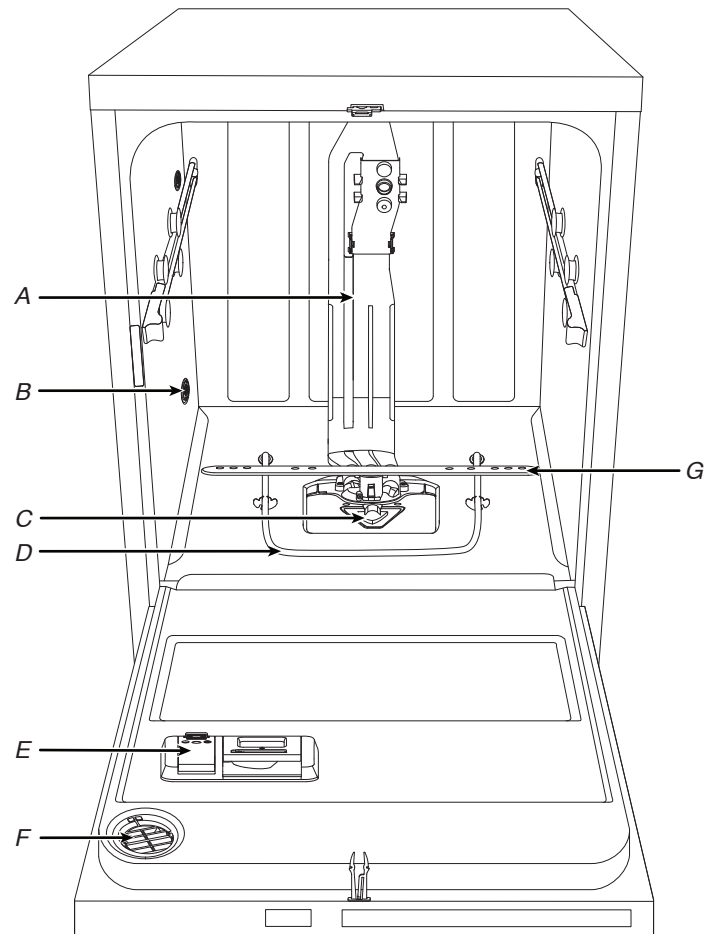

- A. *Water feed tube*
- B. *Water inlet opening*
- C. *Coarse filter*
- D. *Heating element*
- E. *Detergent dispenser*
- F. *Active vents (on some models)*
- G. *Lower spray arm*

A blue starburst-shaped badge with a white border and a drop shadow, containing the text "Multimedia Enhanced" in white.

**Multimedia
Enhanced**

Section 4: Component Access

This section provides service parts access, removal, and installation instructions for the “KitchenAid® and Maytag® 24” Microfiltration Dishwashers.”

- Insulation Blanket and Door Latch Strike
- Siphon Break
- Accessing Door Components
- Removing the Inner Door and Hinges
- ProDry™ Assembly
- Removing User Interface and Door Latch
- Removing Dispenser Assembly
- Removing the Upper Rack (for Satin Glide rails)
- Removing the Third Level Rack (available on some models)
- Removing Lower Spray Arm and Manifold Assembly
- Under Tub Components
- Removing Heater Assembly
- Removing Drain Pump
- Drip Pan and Float Assembly
- Removing Drain pump and Motor Assembly

Video Available  Look for this ICON through out Section 4.

Insulation Blanket and Door Latch Strike

⚠ WARNING



Electrical Shock Hazard

Disconnect power before servicing.

Replace all parts and panels before operating.

Failure to do so can result in death or electrical shock.

Installing Insulation (Stainless models only)

1. Fasten the blanket on the hooks located on each side of the tube.

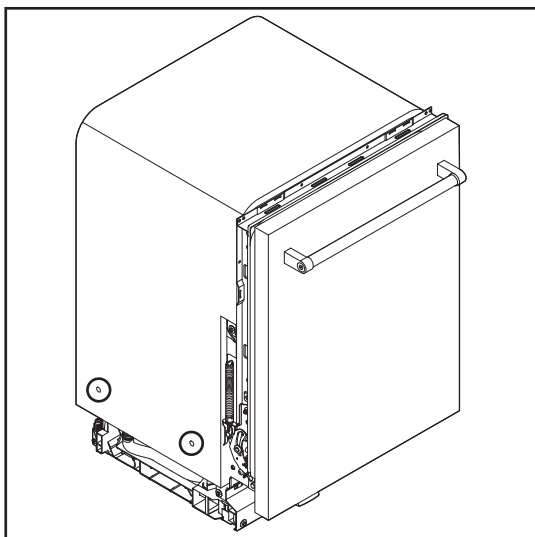

▶ Remove Door Latch Strike

1. Open the dishwasher door.
2. Press down on the round tab in front of the door latch strike.

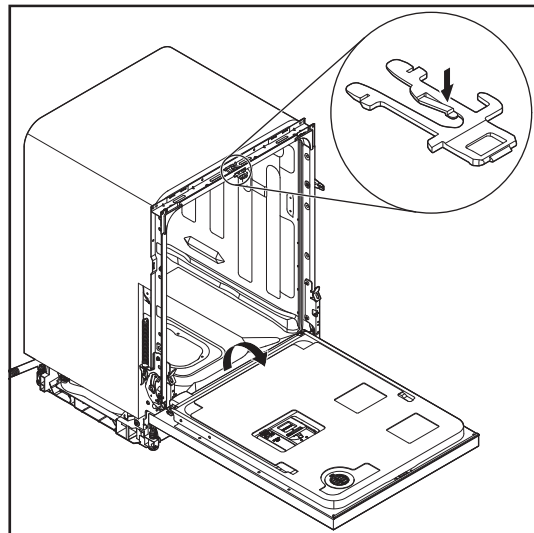

3. While pressing down on the round tab, depress the two outside bars and pull out the latch.

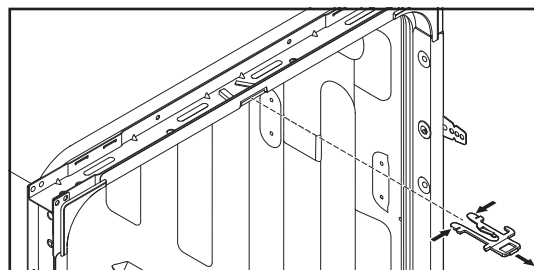

Siphon Break

WARNING



Electrical Shock Hazard
 Disconnect power before servicing.
 Replace all parts and panels before operating.
 Failure to do so can result in death or electrical shock.

Tools Needed:



Oil filter wrench or 90 degree bent nose pliers

1. Locate siphon break nut inside tub back lower left corner.
2. Use oil filter wrench or bent nose pliers to loosen siphon break nut inside tube by turning it counterclockwise.

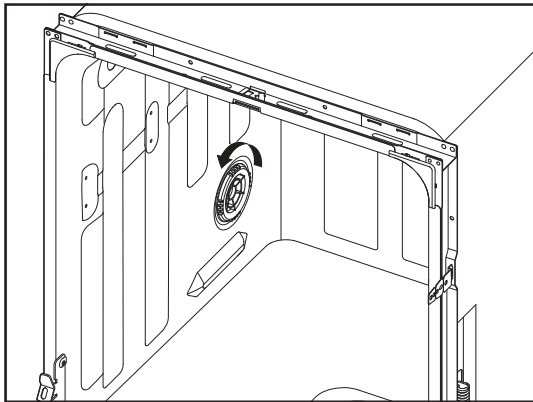

3. Disconnect water inlet hose. Using pliers, squeeze water inlet clamp and pull hose away from siphon break.

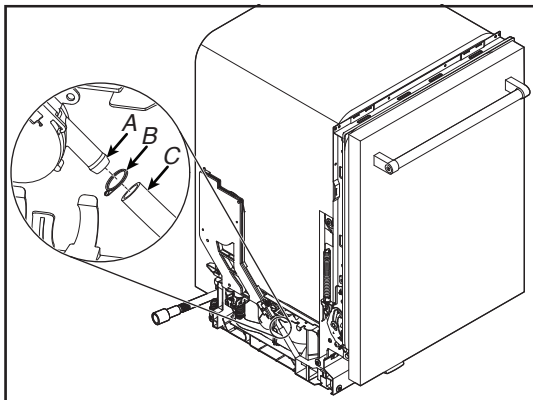

A. Siphon Break Assembly
 B. Clamp
 C. Water Inlet Hose

4. Disconnect drain pump hose. Remove black plastic C-clamp securing drain pump hose to siphon break and pull hose down and away from siphon break assembly.

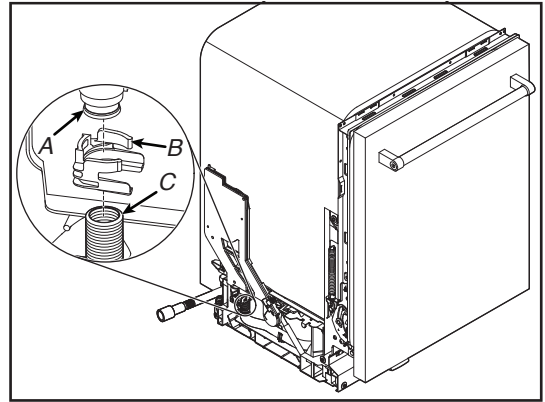

A. Siphon Break Assembly
 B. C-Clamp
 C. Drain Pump Hose

5. Disconnect drain pump output hose. Using pliers, squeeze drain hose output clamp and pull down on hose away from siphon break assembly.

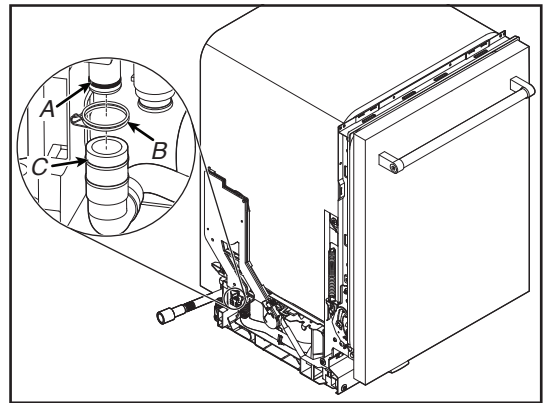

A. Siphon Break Assembly
 B. Clamp
 C. Drain Pump Output Hose

6. Using pliers squeeze plastic retainer together and pull siphon break assembly out and up to remove.

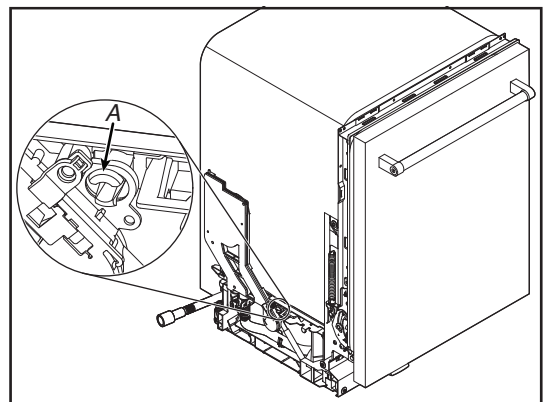

A. Plastic Retainer

▶ Accessing Door Components

⚠ WARNING



Electrical Shock Hazard
Disconnect power before servicing.
Replace all parts and panels before operating.
Failure to do so can result in death or electrical shock.

3. Lift the outer door assembly up and away with enough room to disconnect the ACU harness and clip. Unclip the harness from the harness retaining clip.

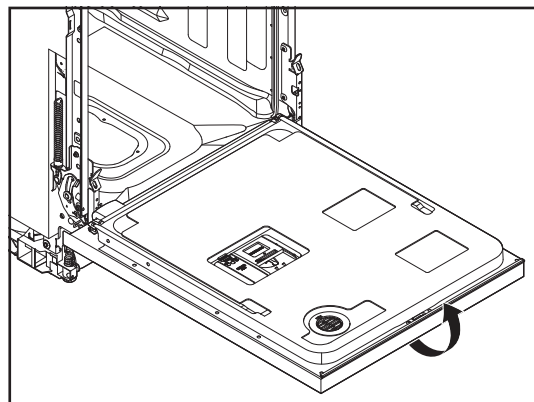

▶ Remove the Outer Door Panel

1. Unplug dishwasher or disconnect power.
2. Using a TORX[†] T15 screwdriver, remove the six short screws (three on each side) and three long as shown in below image:

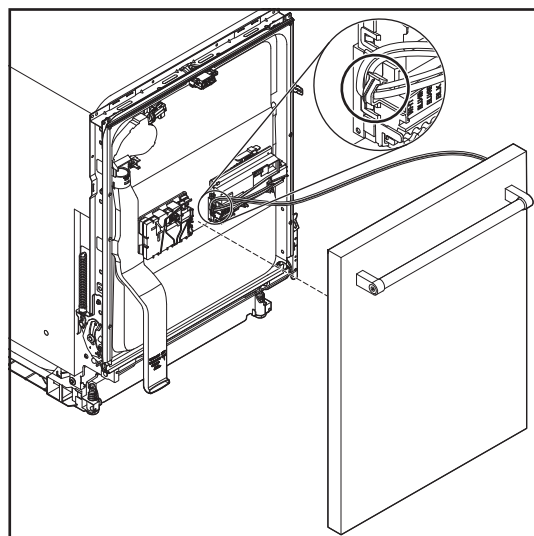
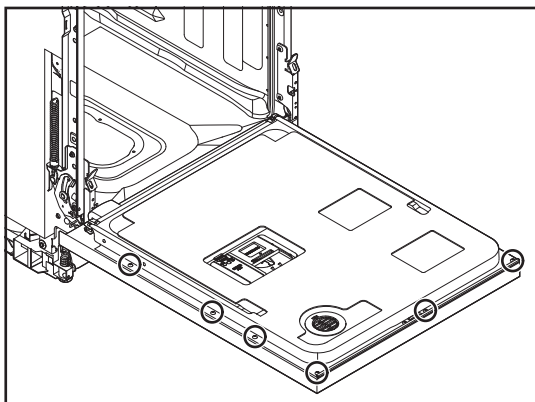

NOTE: Leave the (short) screw to the left of the door latch in place as this screw secures the door latch to the door.

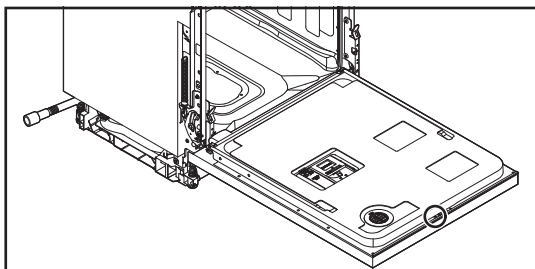

[†]Torx T15 and T20 are trademarks of Acument Intellectual Properties, LLC.

Accessing Door Components (Continued)

4. Disconnect the fan, the dispenser and door latch harness connection before moving forward. Disconnect the fan and door latch harness by pushing up on the connector tab and pull the harness connector off.

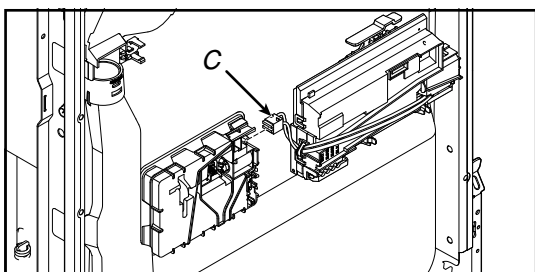
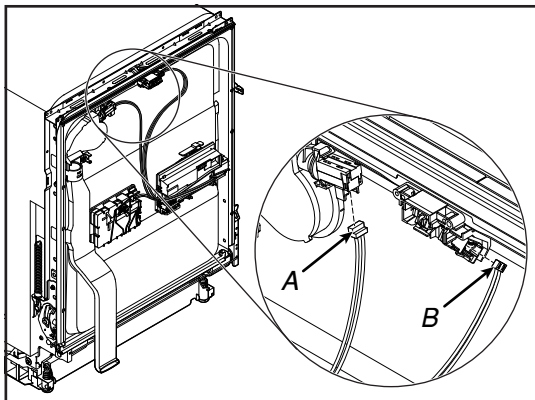

A. Fan Connector
B. Door Latch Connector
C. Dispenser Connector

5. Remove the 1/4" nut securing the ground wire.

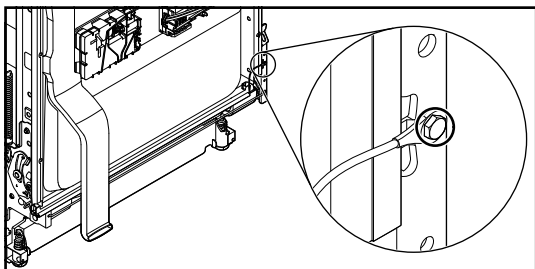

6. Flip the ACU cover own door. Push up on the connector tab and pull the harness connector off the board.

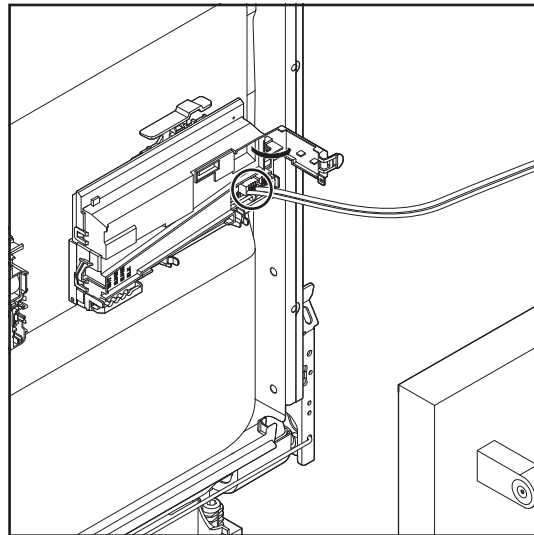

Remove the ACU

7. To remove ACU, use a flat blade screwdriver to push in on tab. Then lift up on ACU and slide to the left.

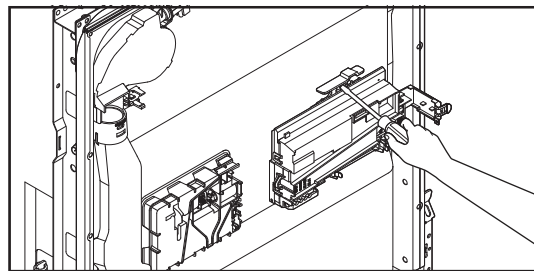

8. Turn the ACU assembly over and depress the three tabs to release the wire harness connector cover. Disconnect wire harness connectors and replace ACU.

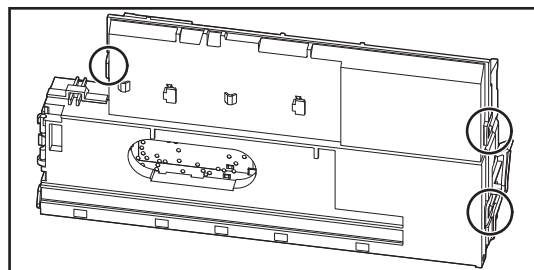

▶ Removing the Inner Door and Hinges

⚠ WARNING



Electrical Shock Hazard

Disconnect power before servicing.

Replace all parts and panels before operating.

Failure to do so can result in death or electrical shock.

Remove the Inner Door

1. Unplug dishwasher or disconnect power.
2. Complete the step [1-4](#) from Remove the Outer Door Panel section.
3. Remove the cross-bar from the hinges.

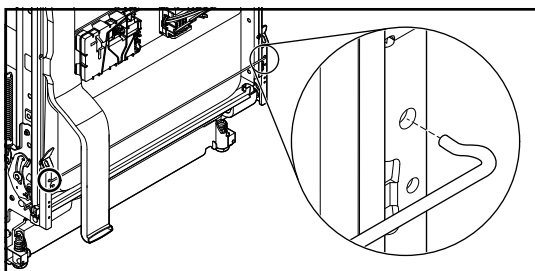

4. Open the inner door slightly and insert 7/64" drill bits (or Allen wrench's) into hinge hole as shown in below image:

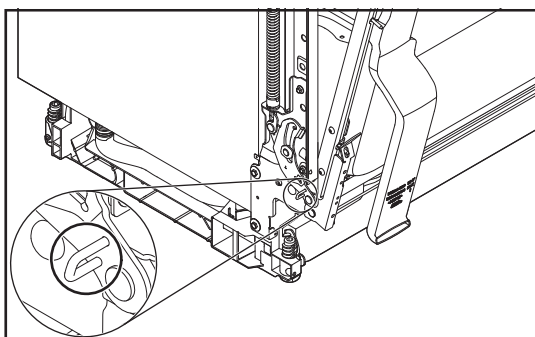

This will keep the hinge slightly open and make replacing the inner door easier.

5. Remove the two T20 screws attaching the inner door panel to the hinge and repeat for other hinge. Then lift up on inner door to remove.

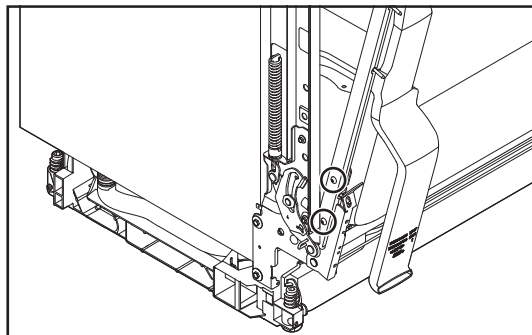

Remove the Hinge

6. Using a 5/16" nut driver remove two rear screws and use a 1/4" nut driver to remove the front two screws. Repeat the step for other hinge.

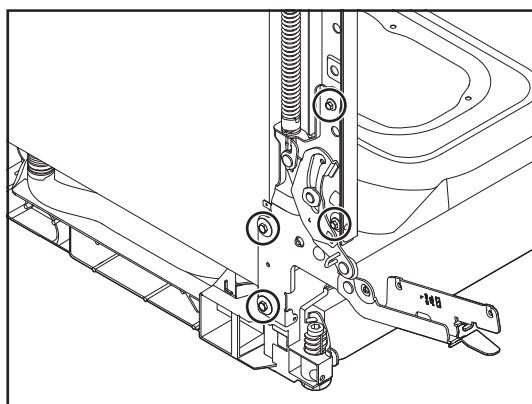

NOTE: While holding on to the hinge, keep the drill bit or allen wrench in place to secure the closing of hinge.

7. Remove the hinge by sliding off from the machine.
8. Reinstall the new hinge in same position as the old hinge was removed.

NOTE: Leave the pin inserted until the hinge, inner door, and crossbar is installed.

IMPORTANT: Use the 1/4" nut driver to install the top front screws first for alignment. Then using the 5/16" nut driver install the bottom front screws.

 ProDry™ Assembly

⚠ WARNING



Electrical Shock Hazard
 Disconnect power before servicing.
 Replace all parts and panels before operating.
 Failure to do so can result in death or electrical shock.

4. Disconnect wax motor connector by pressing down on tab and lifting up on harness connector.

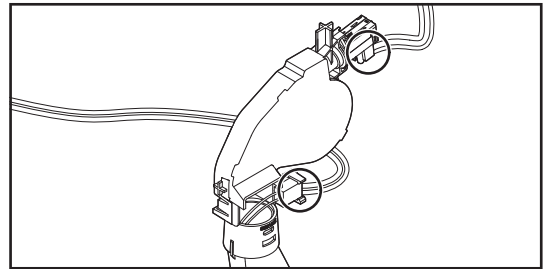

5. Remove fan harness by pushing down on tab and lifting up on harness. Refer the above image.
6. To remove vent assembly, use a screwdriver to push in on tab shown and pull vent away from wax motor.

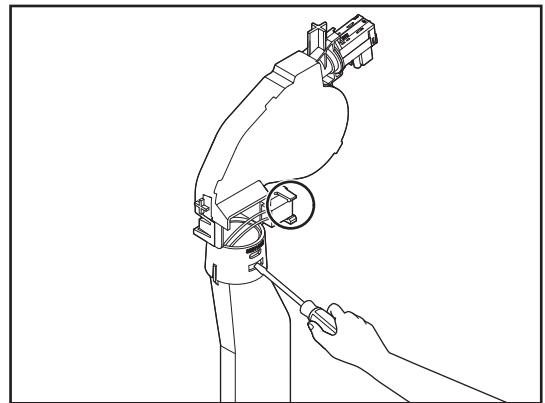

Tools Needed:



90 degree bent nose pliers

1. Complete the step [1-4](#) from Remove the Inner Door section.
2. Using 90 degree bent nose pliers turn the ProDry™ vent counterclockwise to loosen and remove.

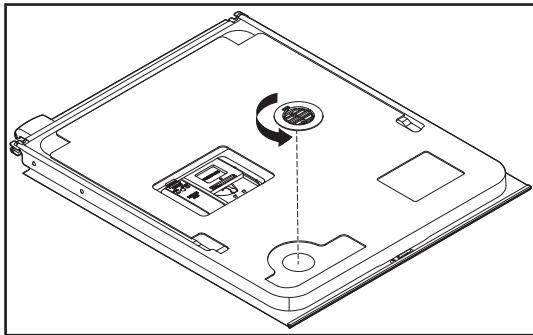

3. The ProDry™ assembly can now be removed.

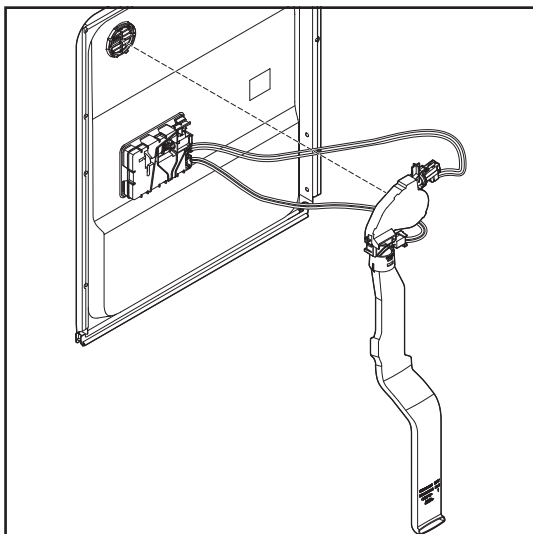

Removing User Interface and Door Latch

⚠ WARNING



Electrical Shock Hazard

Disconnect power before servicing.

Replace all parts and panels before operating.

Failure to do so can result in death or electrical shock.

Remove the User Interface

1. Unplug dishwasher or disconnect power.
2. Complete the step [1-6](#) from ProDry™ Assembly section.
3. Use a T15 screwdriver to remove the three (3) screws securing the UI to the outer door panel.

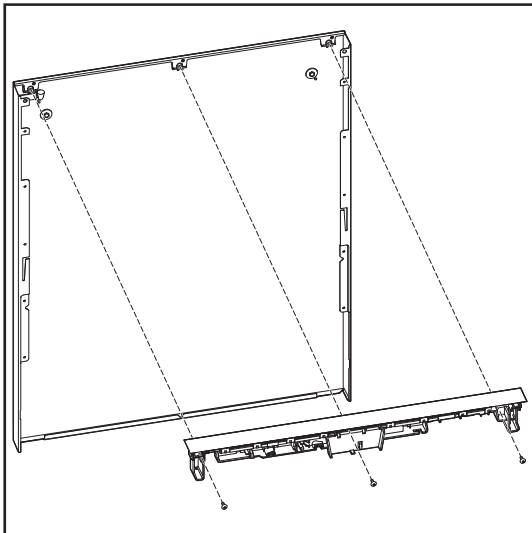

NOTE: The light pipe is not removed during UI replacement. It remains attached to the outer door panel.

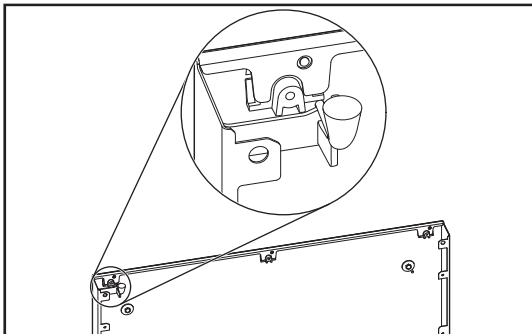

Remove the Latch Assembly

4. Use a T15 screwdriver to remove the one screw attaching the Latch Assembly to the door panel.

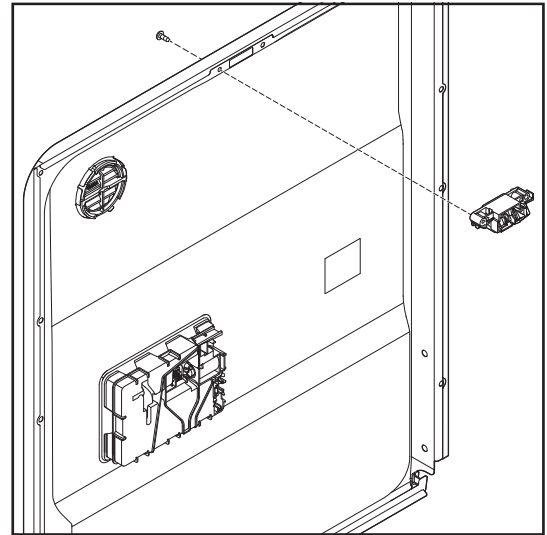

Removing Dispenser Assembly

⚠ WARNING



Electrical Shock Hazard
Disconnect power before servicing.
Replace all parts and panels before operating.
Failure to do so can result in death or electrical shock.

1. Unplug dishwasher or disconnect power.
2. Complete the step [1-4](#) from Remove the Outer Door Panel section.
3. Disconnect dispenser harness by pushing down on harness retainer while pulling the harness from the dispenser.

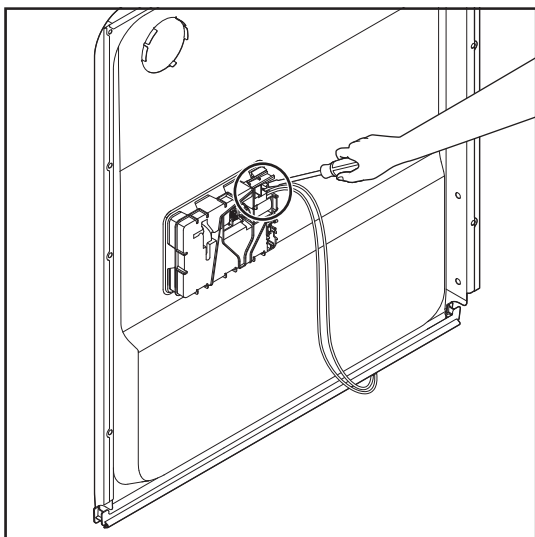

4. Remove dispenser by prying each clip away from the dispenser and lifting it away from the door panel.

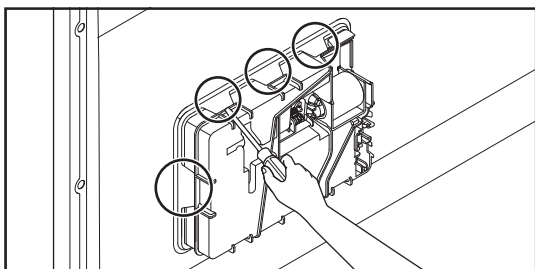

Locking Clips for Dispenser Assembly

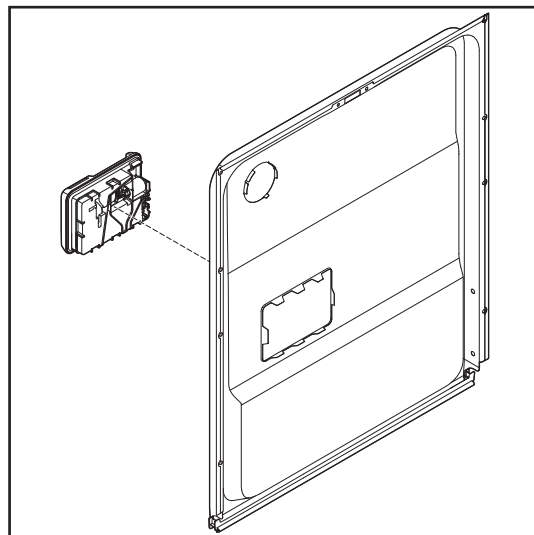

Removing the Upper Rack (for Satin Glide rails)

1. Open the dishwasher door.
2. To gain access to the removable tabs on the tracks/rails, pull the upper rack forward about halfway out of the tube.

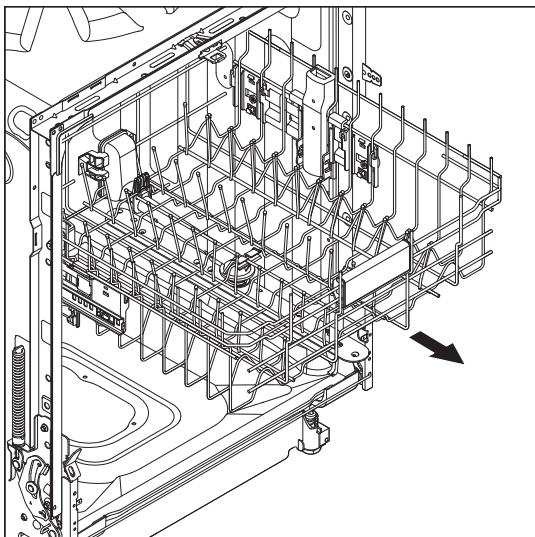

3. On one side, press the tab on the track in and pull up the front end of the rack out of the track.

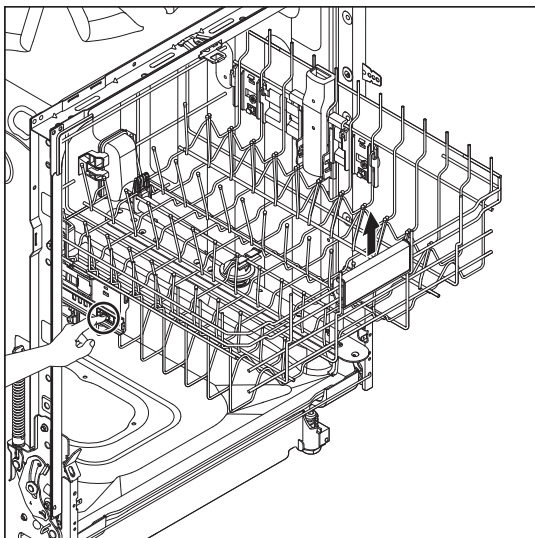

4. Then repeat this step on the other side to completely remove the front end of the rack.
5. Then remove the back end of the rack, by pulling the back end out with a slightly forward, and then upward motion.

Remove Roller and Rack Adjuster Assembly

6. Remove rack adjust retainer. Using a flat blade screwdriver push in on the tab.

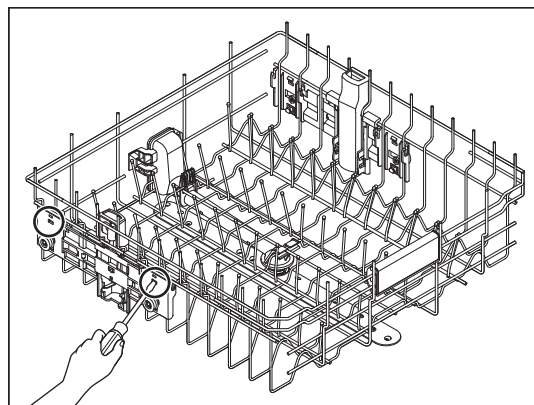

7. While pushing in on tab lift up on the rack adjust retainer to remove.

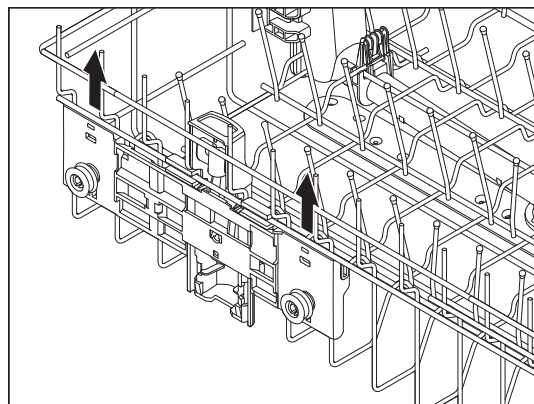

8. Repeat for other rack adjust tab.
9. Using a flat blade screwdriver push in on two tabs as shown in below image:

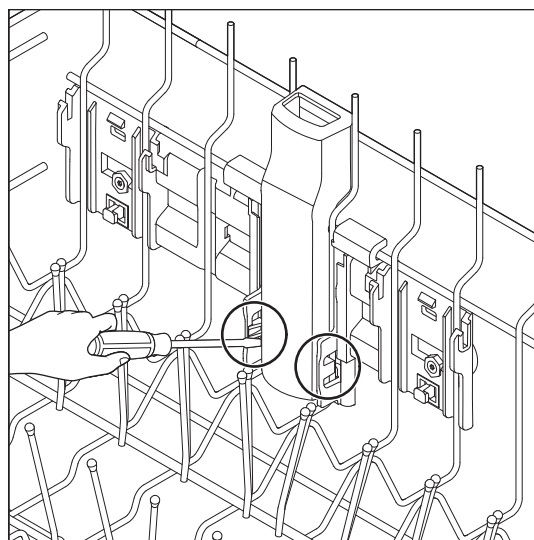

Removing the Upper Rack (Continued)

- From outside of the rack lift up from the bottom of the roller/rack adjust and remove.

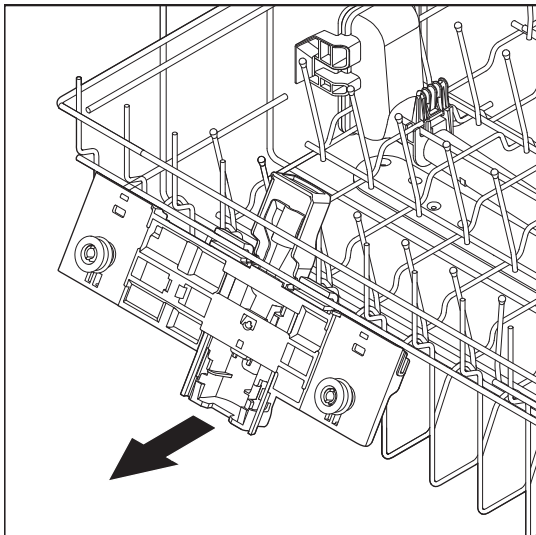

- Pull spray arm assembly away to remove.

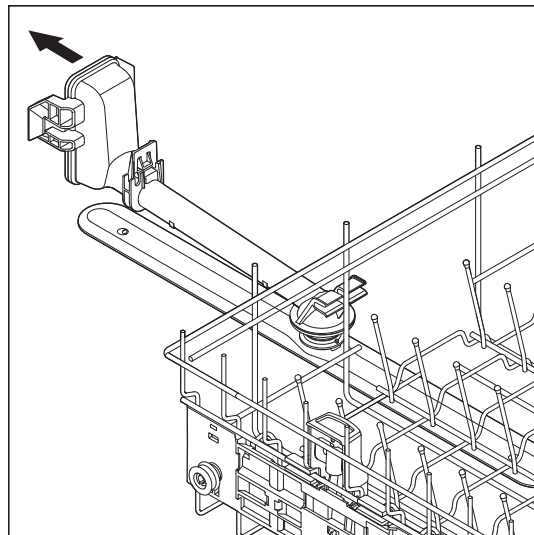

Remove Spray Arm Assembly

- Complete the steps 1-5 from Removing the Upper Rack (for SatinGlide rails) section.
- Using a flat blade screwdriver push in on the tab.

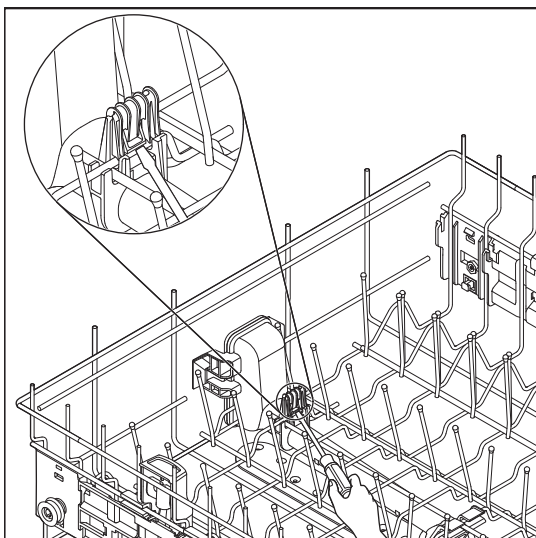

Reinstall Spray Arm Assembly

- Align spray arm assembly as shown in below image and push into place.

NOTE: Spray arm assembly is offset.

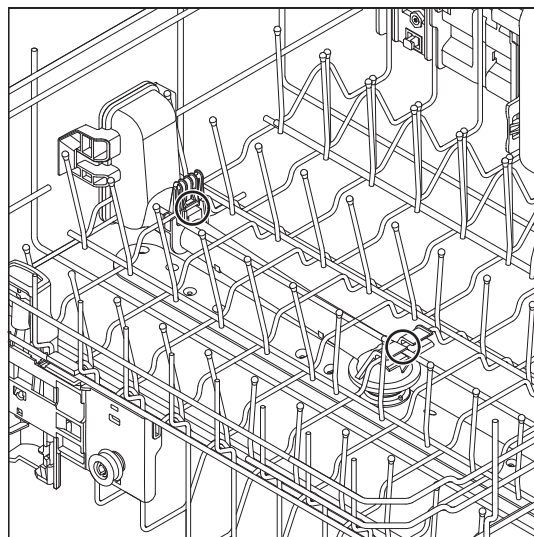

- Push up on spray arm assembly to lock in place.

▶ Removing the Third Level Rack (available on some models)

⚠ WARNING



Electrical Shock Hazard
 Disconnect power before servicing.
 Replace all parts and panels before operating.
 Failure to do so can result in death or electrical shock.

1. Open the dishwasher door.
2. To access track stops, pull the rack forward until it stops and clicks into place.
3. To open track stops, flip the track stop to the outside of the track.
4. After opening both track stops, slide front wheels up and out of the slot in track. Continue to pull rack forward in track and slide the back wheels up and out of the track.

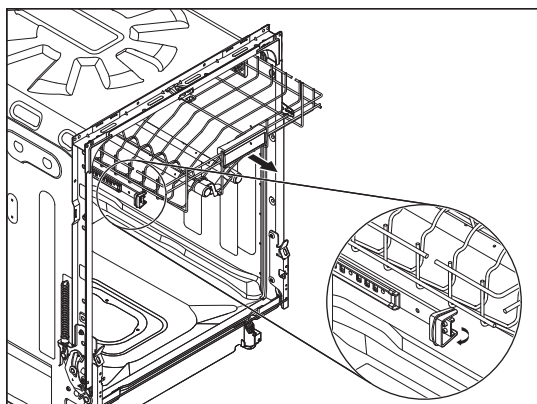

5. Close track stops.
6. Slide rack tracks back into dishwasher.

Remove the Rack Rails

1. Turn white plastic rail retainers counterclockwise to remove third level rack rails.

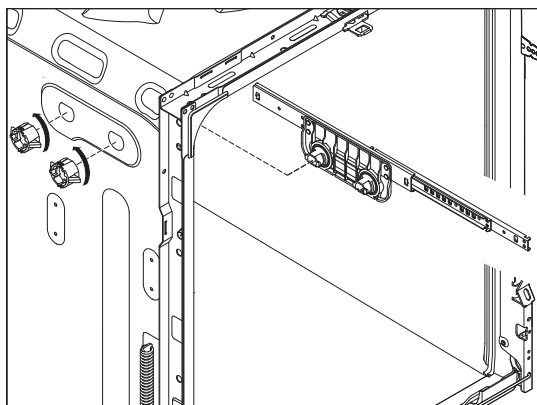

2. Use a 5/16" nut driver to remove the four bolts holding the upper rack rail.

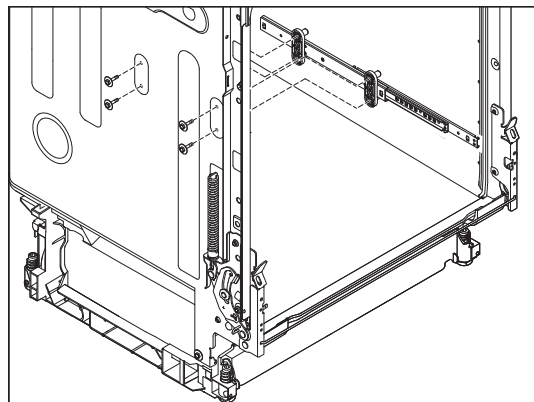

Remove the Wash Tube Cover

1. Complete the steps 1-6 from Removing the Third Level Rack section.
2. Pry two tabs outward and push to disengage Wash Tube Cover from Manifold Drive Box.

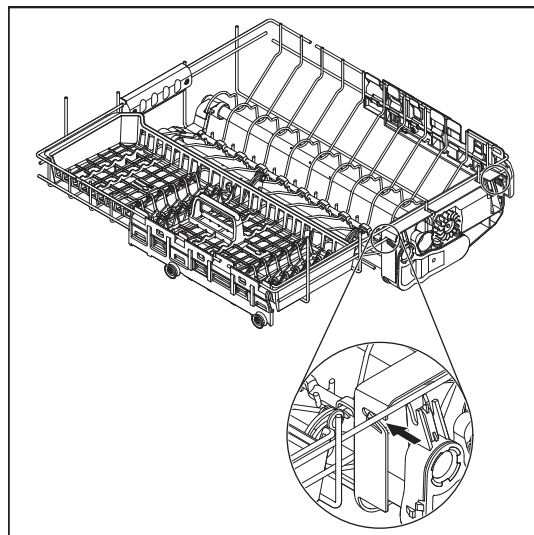

3. Spread the two tabs to remove Manifold Drive Box from rails.

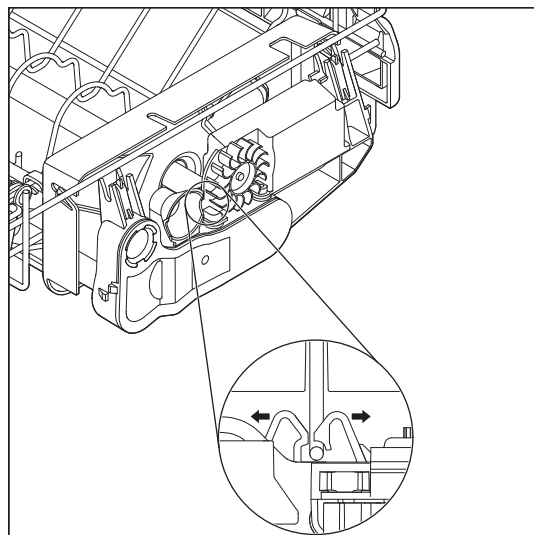

Removing the Third Level Rack (Continued)

Remove the Spray Arms

4. Pull spray arms away from Manifold Drive Box.

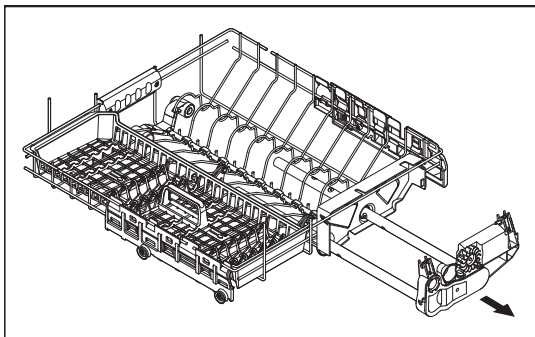

5. To remove Tube Hanger from the Tube Hanger Bracket push Hanger in direction shown in below image:

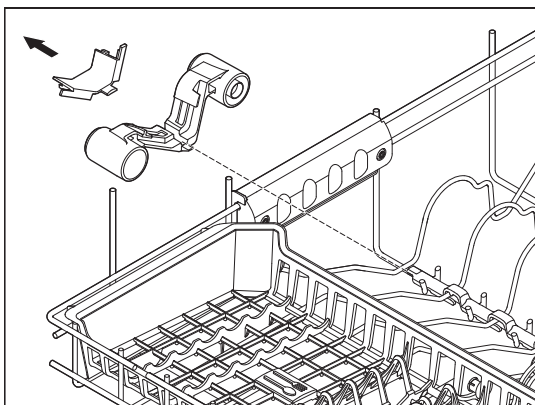

Remove the Roller Assembly

6. Using a flat blade screwdriver push in on the three tabs. Then lift roller assembly up and away from rack.

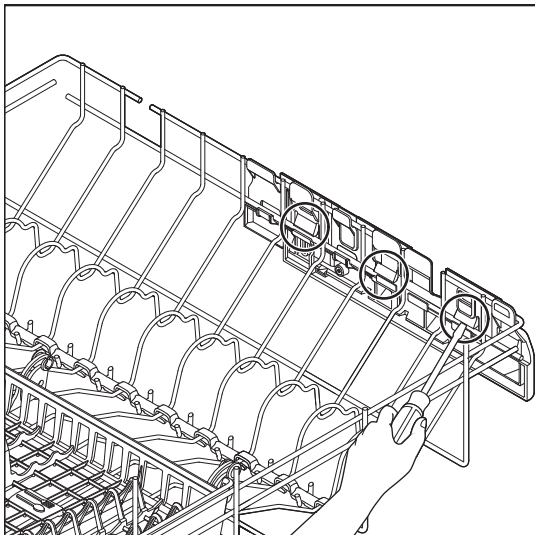

Remove the Spray Bar Cover

7. Use a flat blade screwdriver to pry four locking tabs to remove spray bar cover.

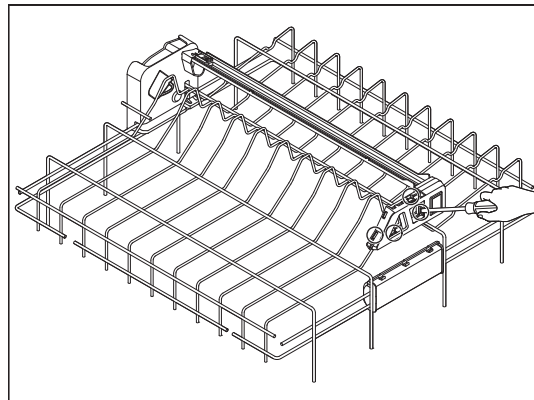

Remove the Spray Bar

8. Use a flat blade screwdriver to pry locking tab to remove spray bar.

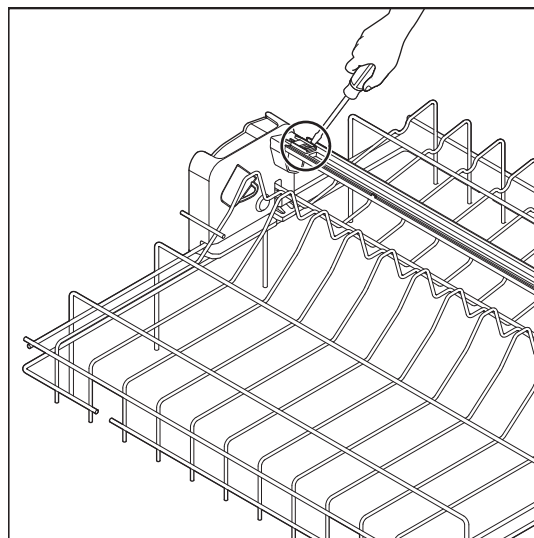

Removing Lower Spray Arm and Manifold Assembly

▶ Remove the Lower Spray Arm

1. Open the dishwasher door.
2. Complete the steps [1-5](#) from Removing the Upper Rack section.
3. Complete the steps [1-6](#) from Removing the Third Level Rack section.
4. To remove lower spray arm lift up and turn counterclockwise.

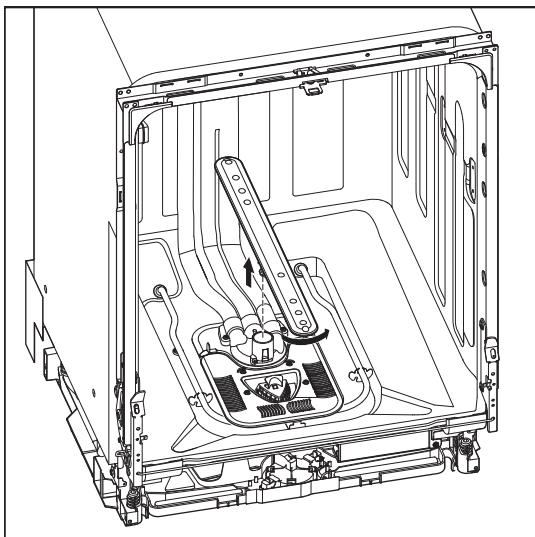

Remove the Manifold Assembly

6. To remove manifold assembly remove two T15 screws at diverter cover.

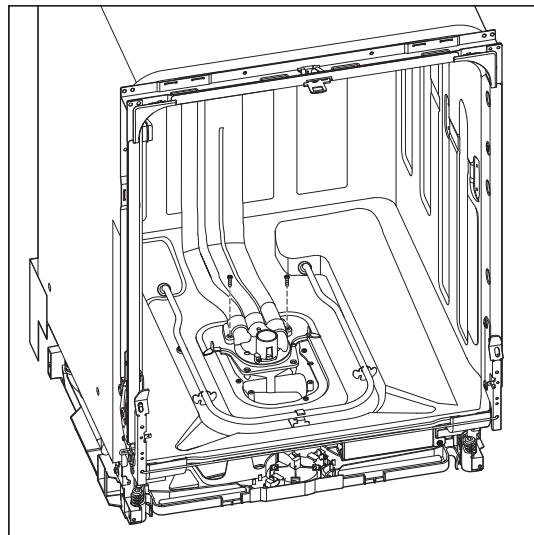

7. Starting at the top, use a flat blade screwdriver to press in on the four tabs. The manifold assembly can then be removed from the tub.

Remove the Filter Cover

5. To remove filter cover remove four T15 screws.

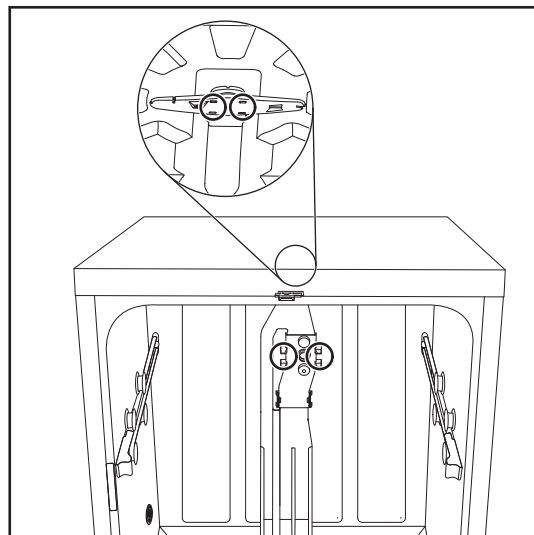
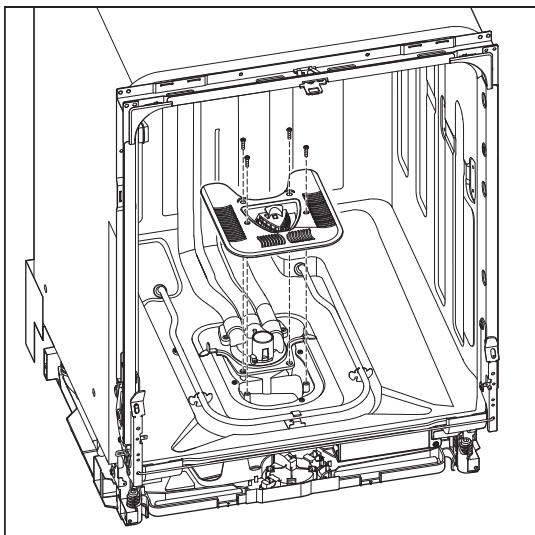

Under Tub Components

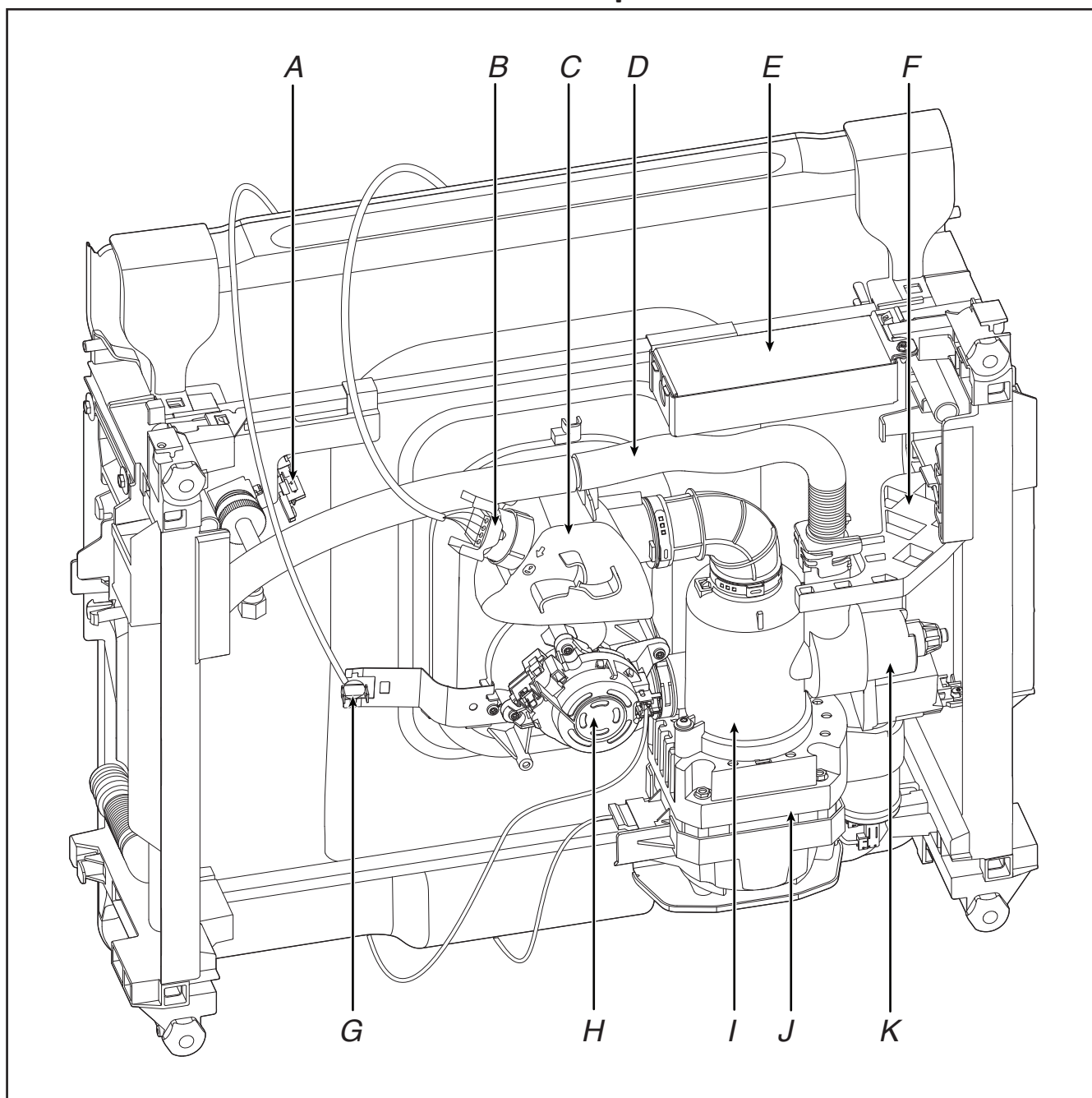

- A. *Fill Valve*
- B. *OWI Sensor*
- C. *Sump*
- D. *Drain Hose*
- E. *Junction Box*
- F. *Drain Pump Bracket*
- G. *Thermostat*
- H. *Diverter*
- I. *Rotating Inlet Filter*
- J. *Wash Motor*
- K. *Exclusive Drain Pump
with chopper*

Removing Heater Assembly

⚠ WARNING



Electrical Shock Hazard

Disconnect power before servicing.
Replace all parts and panels before operating.
Failure to do so can result in death or electrical shock.

1. Unplug dishwasher or disconnect power.
2. Locate the heater terminals at the bottom of the dishwasher. Disconnect wires from both heater terminals.

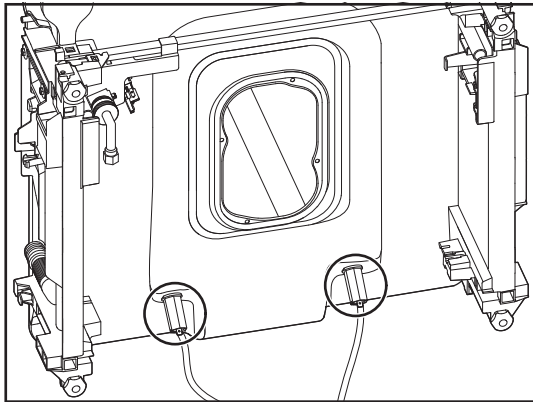

3. Remove both heater element nuts.

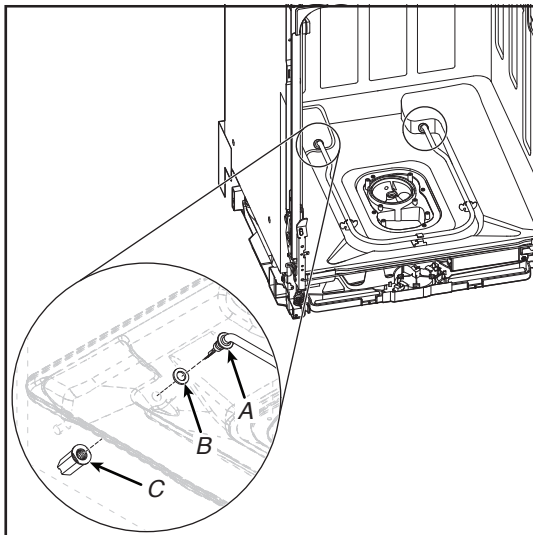

A. Heater Element Assembly
 B. Heater Washer
 C. Heater Element Nut

4. Remove heater element assembly from tub.

▶ Removing Drain Pump

⚠ WARNING



Electrical Shock Hazard

Disconnect power before servicing.
Replace all parts and panels before operating.
Failure to do so can result in death or electrical shock.

1. Unplug dishwasher or disconnect power.
2. Uninstall dishwasher so that it can be pulled half way out of cabinet.
3. Turn off water supply to dishwasher. Disconnect drain hose if necessary. Unscrew anchors to cabinet.
4. Complete the steps 2-8 from Removing Drain pump and Motor Assembly section.
5. Locate the drain pump in the lower front right of dishwasher.
6. Push in on tab and turn drain pump 1/4" turn counterclockwise to remove.

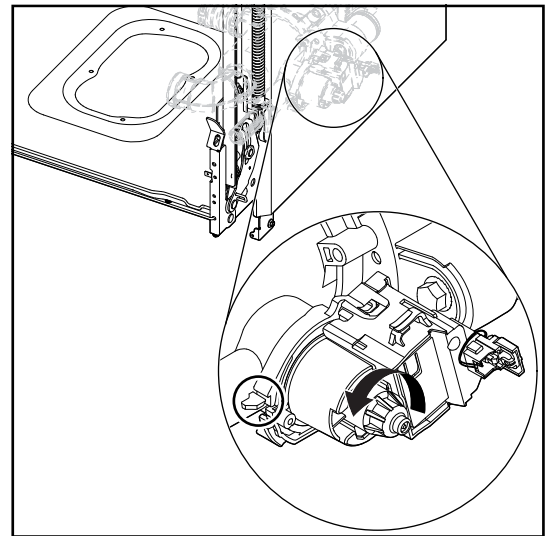

7. After outer surface pass the stopping stub, then remove the pump from the interface.

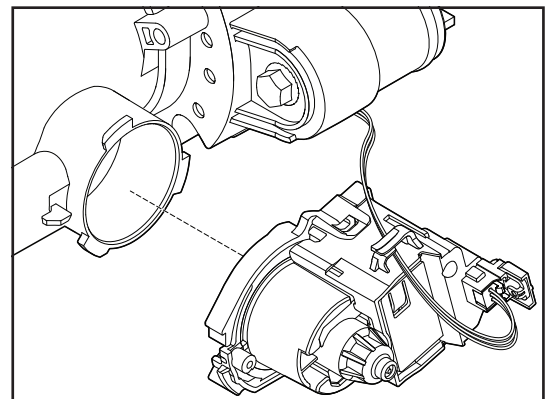

Removing Drain Pump (Continued)

Pump Location and Pump Types

Removal of drain pump harness connector with Terminal Position Assurance (TPA)

- Remove harness from strain relief before removing the connector.

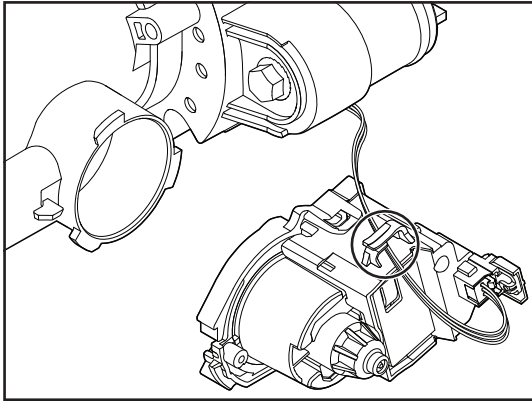

- Lightly pinch and push hooks up to move the faceplate up to unsecure the connector.

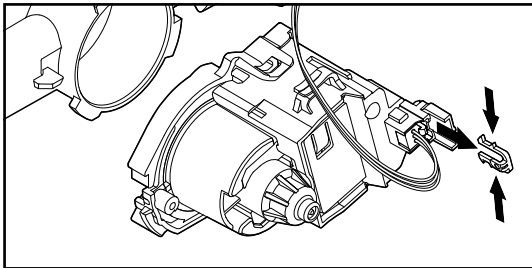

- Push on black tab to release harness connection.

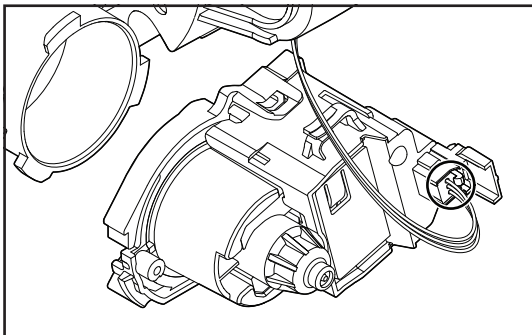

- Lift up to fully remove harness connection from component.

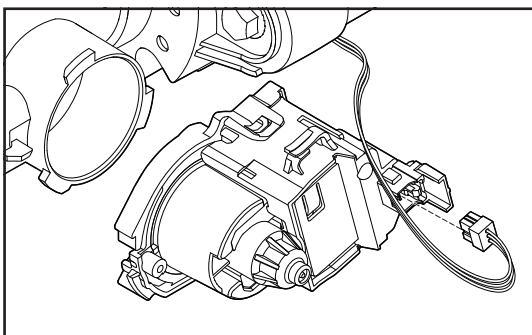

Removal of drain pump harness connector with Connector Position Assurance (CPA)

- Release the two tabs (one each side) from one side, then the other side.

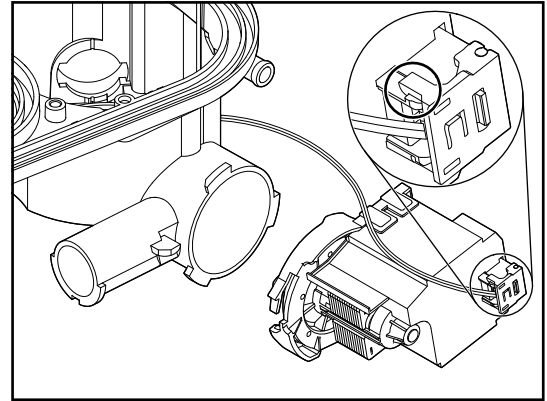

- Lift up the lid to access the connector.

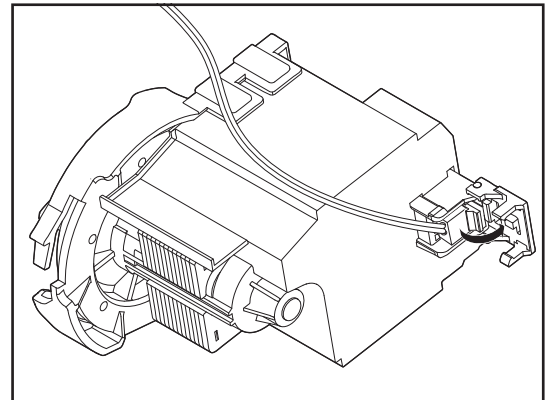

- Push the connector mounting tab, then lift up the connector to remove from the casing.

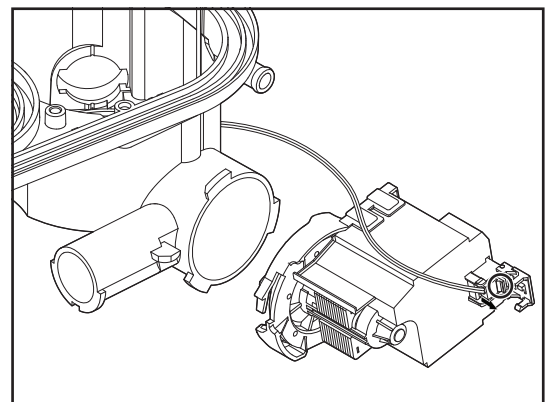

Drip Pan and Float Assembly

WARNING



Electrical Shock Hazard
Disconnect power before servicing.
Replace all parts and panels before operating.
Failure to do so can result in death or electrical shock.

NOTE: Take caution not to pull too far or too hard as the float switch wire is still connected at this time.

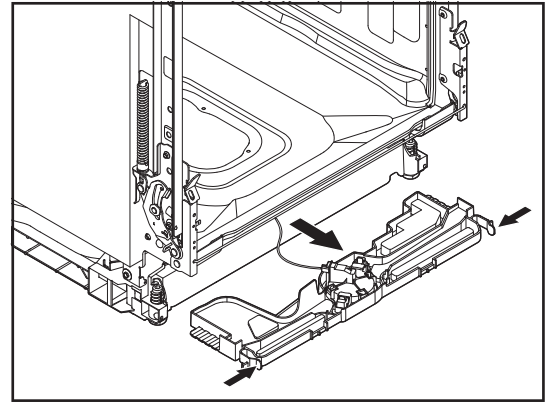

Remove the Drip Pan and Float Assembly

1. Remove toe/access panel using a 5/16" nut driver.

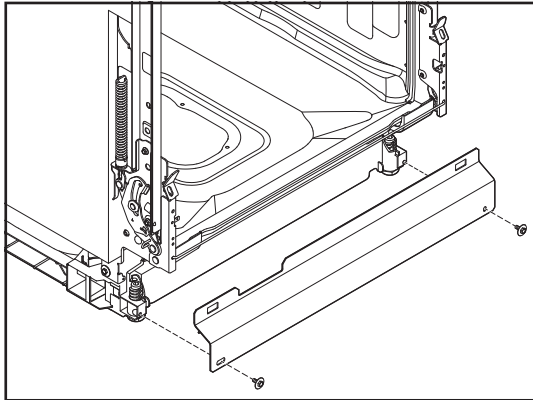

2. To remove the drip pan assembly, press the snap at each side of the plastic tray in toward the center of the product and pull toward yourself.

Remove the Float Switch Wire

3. To remove the float switch wire, gently depress the connector latch tab and then pull the connector out of the housing. To remove the float push in on the two tabs and lift up on the float.

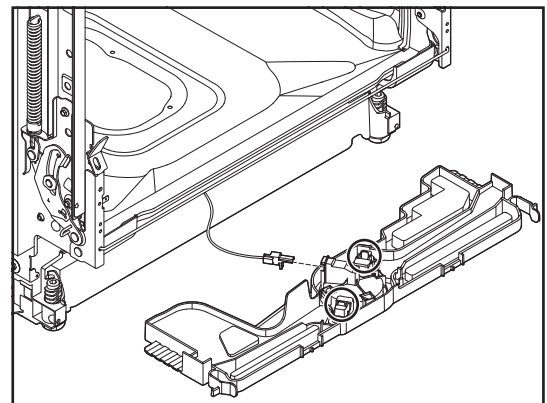

▶ Removing Drain pump and Motor Assembly

⚠ WARNING



Electrical Shock Hazard
Disconnect power before servicing.
Replace all parts and panels before operating.
Failure to do so can result in death or electrical shock.

1. Unplug dishwasher or disconnect power.
2. Complete the steps [1-4](#) from Drip Pan and Float Assembly section.
3. Complete the steps [1-7](#) from Removing Lower Spray Arm and Manifold Assembly section.
4. Remove four T15 screws to sump.

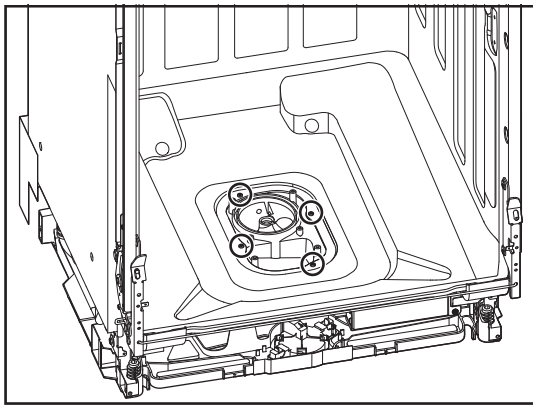

5. Disconnect water supply under sink if necessary.
6. Disconnect drain hose under sink if necessary.
7. Disconnect electrical under sink or at junction box if needed.
8. Pull dishwasher out from under the counter and lay it on it's back.

9. Move junction box out of the way by twisting up on left side and pulling it up and away from the retaining bar.

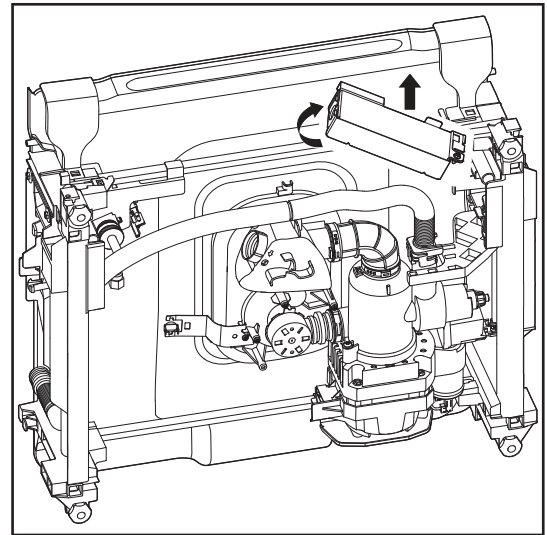

10. To remove plastic drain pump bracket, use a standard screwdriver to push down on tab and push bracket away from you.

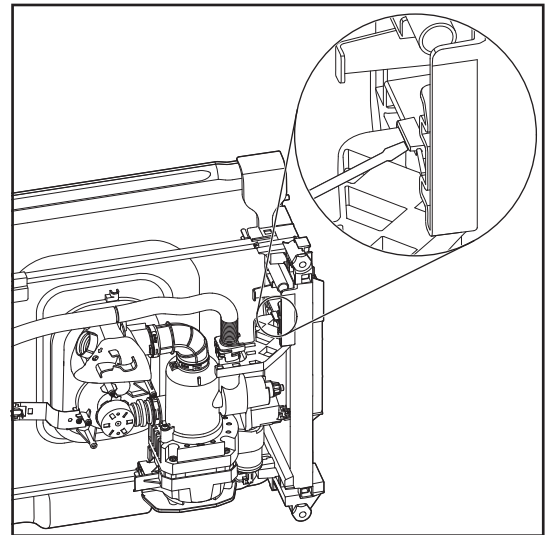

Removing Drain pump and Motor Assembly (Continued)

11. Remove black plastic hose retainer and disconnect drain hose from drain pump port.

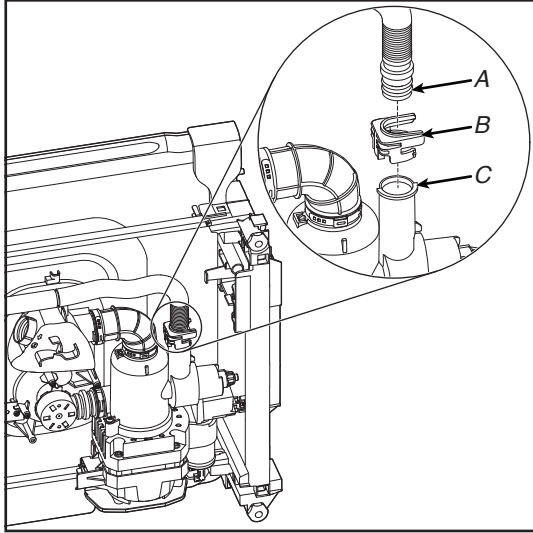

A. Drain Pump Port
B. Plastic Hose Retainer
C. Drain Pump Hose

12. Complete the steps [1-10](#) from Remove the Drain Pump section.

13. Remove plastic screw/plug on the right side of the motor bracket using a Phillips screwdriver.

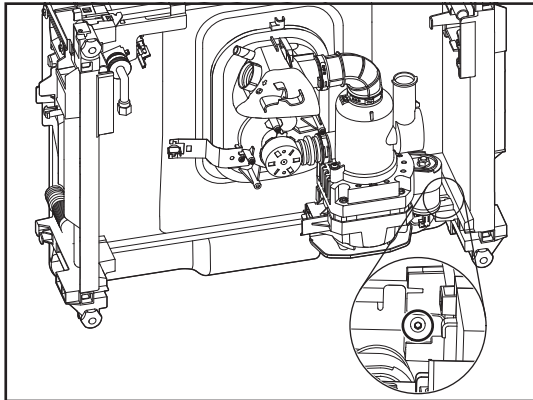

14. Unclip harness from the sump. Disconnect wire harness connectors to diverter motor and wash motor..

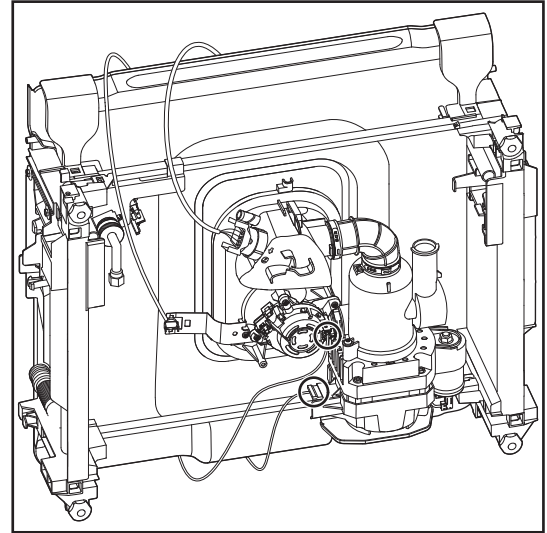

15. Remove OWI by turning in counterclockwise a quarter turn.

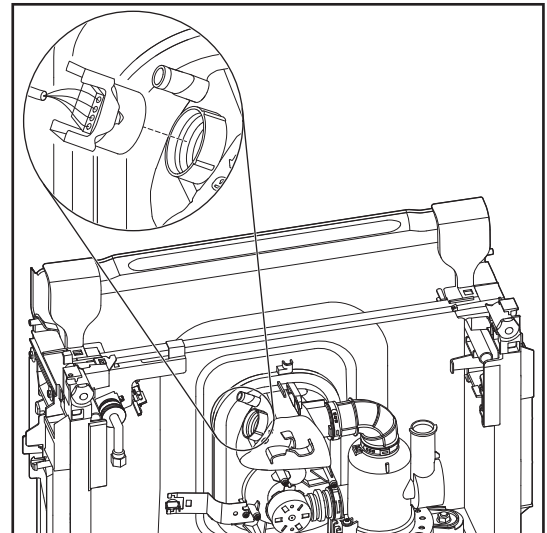

Removing Drain pump and Motor Assembly (Continued)

16. Slide sump and motor assembly to the left along the rear bracket. Lift up on the left side of the assembly and pull it up and away from the rear bracket.

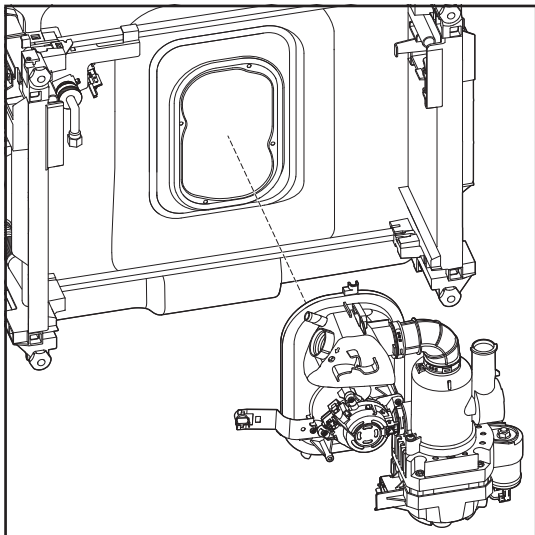

18. Rotate the pump counter clock-wise.

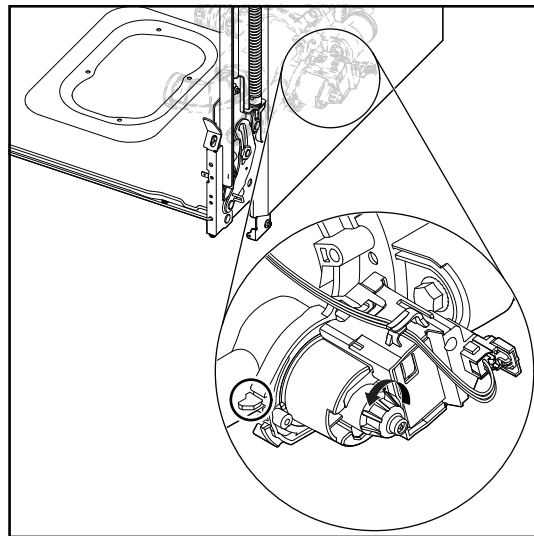

17. Remove thermostat and bracket using a T15 screwdriver.

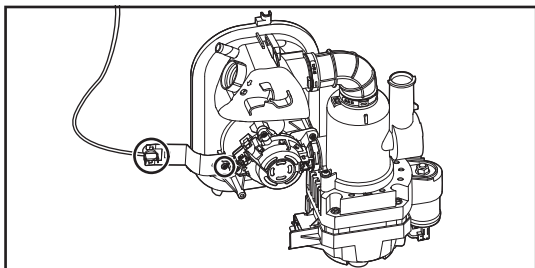

Notes

PRODUCT SPECIFICATIONS & WARRANTY INFORMATION SOURCES

IN THE UNITED STATES:

FOR PRODUCT SPECIFICATIONS AND WARRANTY INFORMATION CALL:

FOR WHIRLPOOL PRODUCTS: 1-800-253-1301

FOR TECHNICAL ASSISTANCE WHILE AT THE CUSTOMER'S HOME CALL:

THE TECHNICAL ASSISTANCE LINE: 1-800-832-7174

**HAVE YOUR STORE NUMBER READY TO IDENTIFY YOU AS AN
AUTHORIZED IN-HOME SERVICE PROFESSIONAL**

FOR LITERATURE ORDERS (CUSTOMER EXPERIENCE CENTER):

PHONE: 1-800-851-4605

FOR TECHNICAL INFORMATION AND SERVICE POINTERS:

www.servicematters.com

IN CANADA:

FOR PRODUCT SPECIFICATIONS AND WARRANTY INFORMATION CALL:

1-800-461-5681

FOR TECHNICAL ASSISTANCE WHILE AT THE CUSTOMER'S HOME CALL:

THE TECHNICAL ASSISTANCE LINE: 1-800-488-4791

**HAVE YOUR STORE NUMBER READY TO IDENTIFY YOU AS AN
AUTHORIZED IN-HOME SERVICE PROFESSIONAL**

**KitchenAid® and Maytag®
24" Microfiltration
Dishwashers
W11499711 Rev B**