

REFRIGERATOR

Repair Parts List

MODEL NUMBER

MSD2651HES

When requesting service or ordering parts, always provide the following information:

- Product Type
- Part Number
- Model Number
- Part Description

MAYTAG®

©2005 Maytag Services

Section: REFRIGERATOR DOOR (SERIES 10)

Model: MSD2651HES

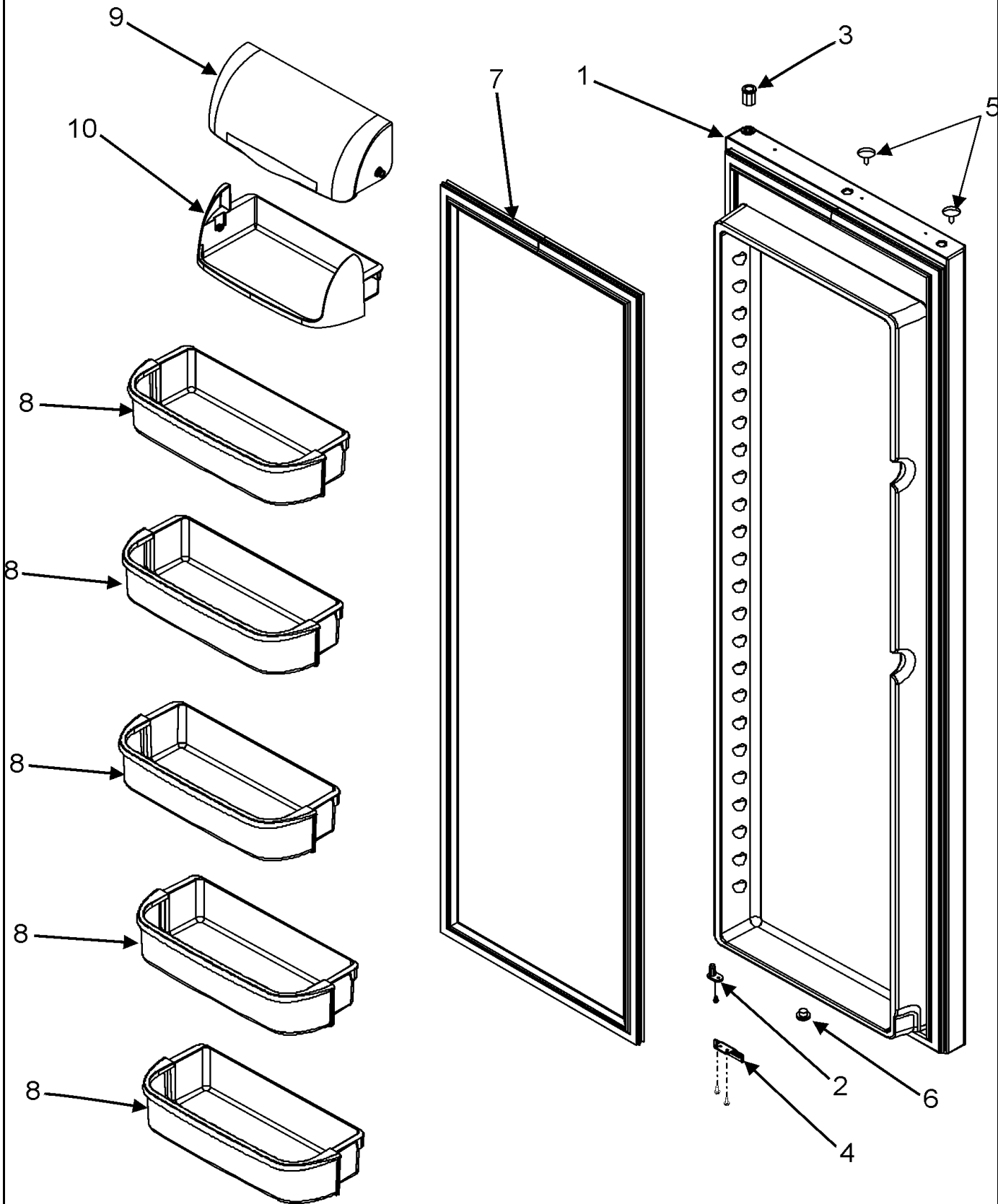

AA54-53

Section: REFRIGERATOR DOOR (SERIES 10)

No.	Part No.	Description	Series	Qty
1	67003810	DOOR ASSY., REF. FOAM (STNLS)	10	1
2	12113204	CLOSURE, DOOR (BLK)	10	1
-	M0220432	SCREW, TC Note: SCREW, CLOSURE	10	1
3	10961002	BUSHING, DOOR (BLK)	10	1
4	12636401B	STOP, DOOR (BLK)	10	1
-	M0211018	SCREW, SM Note: SCREW, DOOR STOP	10	2
5	M0311607	PLUG, BUTTON (GRY)	10	2
6	A3080001	PLUG, BUTTON (BLK)	10	1
7	67003965	GASKET, REF. DOOR (BLK)	10	1
8	67004110	BUCKET-36"REF GAL	10	5
9	67001325	DOOR, DAIRY	10	1
10	67002304	TRAY, DAIRY	10	1

*Color Code (-)=Not Shown #=Series, Serial Prefix or Run No., N=Not Available

Section: FREEZER DOOR (SERIES 10)

Model: MSD2651HES

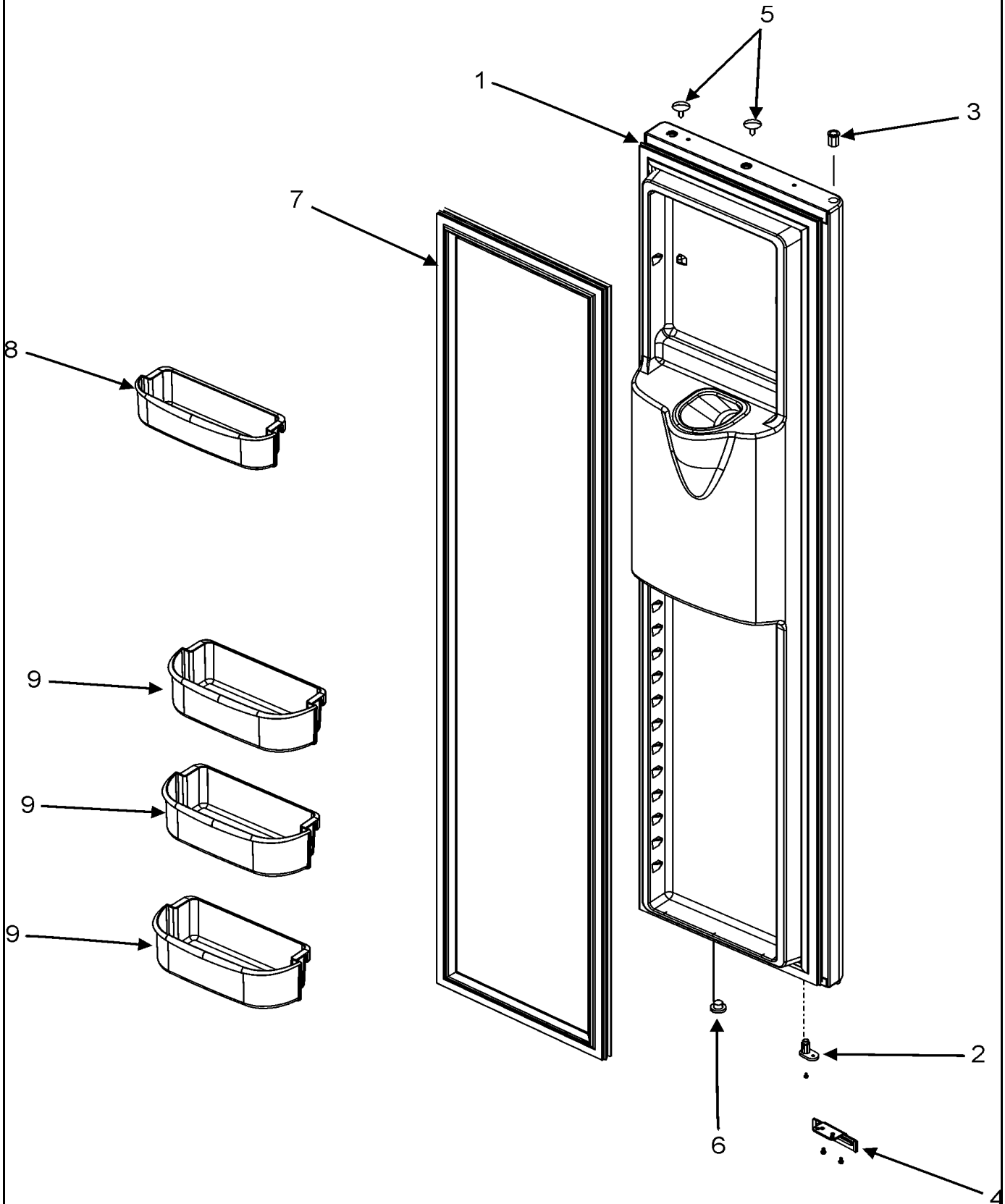

AA55-12

Section: FREEZER DOOR (SERIES 10)

No.	Part No.	Description	Series	Qty
1	67004138	DOOR ASSY., FRZ. FOAM (STNLS)	10	1
-	M0220432	SCREW, TC Note: SCREW, CLOSURE	10	1
2	12571301B	CLOSURE, DOOR (BLK)	10	1
3	12395501B	BUSHING, DOOR (BLK)	10	1
4	12636401B	STOP, DOOR (BLK)	10	1
-	M0211018	SCREW, SM Note: SCREW, DOOR STOP	10	2
5	M0311607	PLUG, BUTTON (GRY)	10	2
6	A3080001	PLUG, BUTTON (BLK)	10	1
7	67003967	GASKET, FRZ. DOOR (BLK)	10	1
8	12556901	BUCKET, UPR FZ DR	10	1
9	12557501	BUCKET, LWR FZ DR	10	3

*Color Code (-)=Not Shown #=Series, Serial Prefix or Run No., N=Not Available

Section: HANDLES (MSD2651HES-SERIES 10)

Model: MSD2651HES

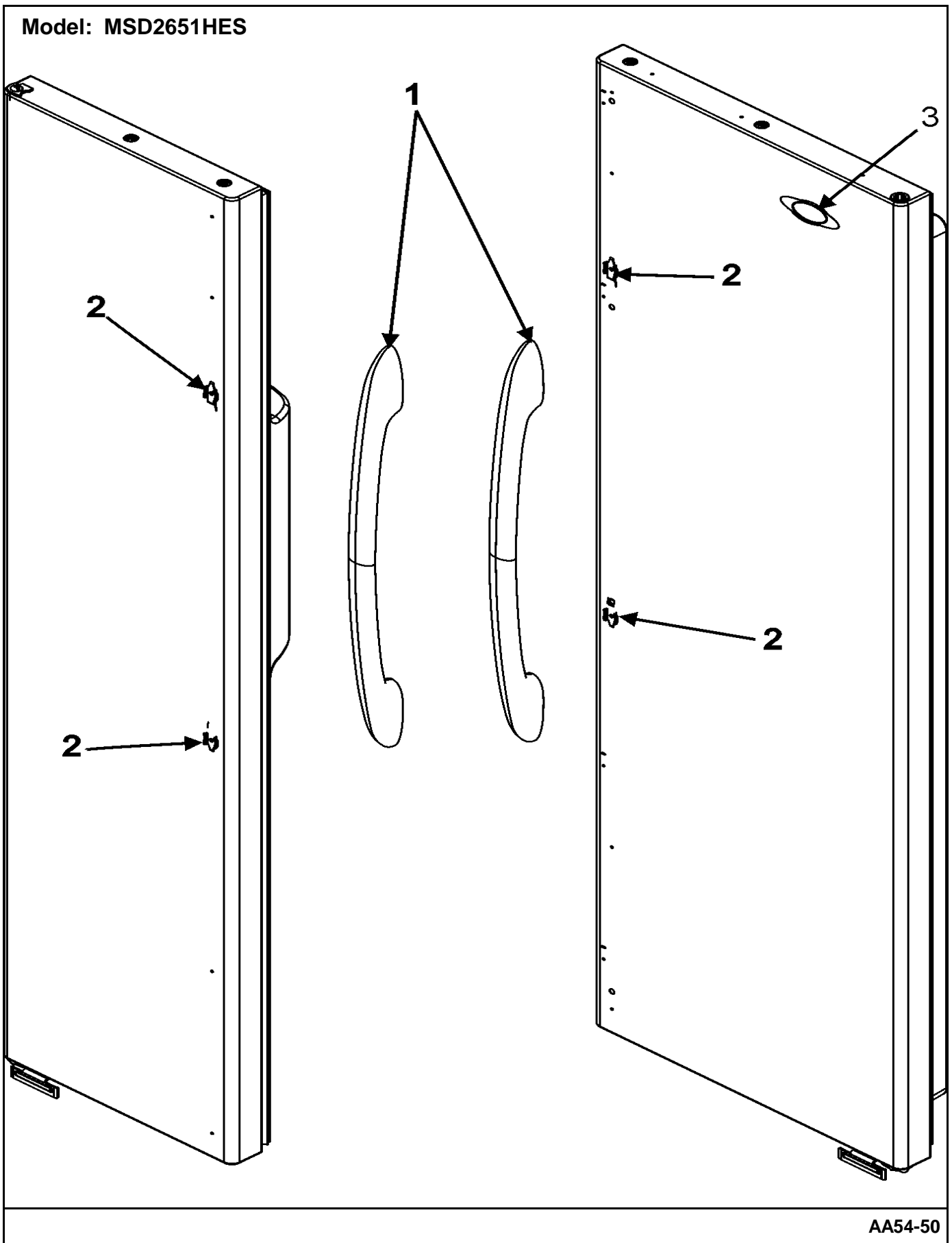

AA54-50

Section: HANDLES (MSD2651HES-SERIES 10)

No.	Part No.	Description	Series	Qty
1	67004056	HANDLE ASSY., DOOR (STNLS)	10	2
-	67004112	CARD, HANDLE RELEASE SS & WS Note: CARD, HANDLE RELEASE	10	1
2	67003337	CLIP, HANDLE BUTTERFLY Note: CLIP, HANDLE	10	4
-	67003800	SCREW, SM #10 Note: SCREW, CLIP	10	4
3	67003877	NAMEPLATE	10	1

*Color Code (-)=Not Shown #=Series, Serial Prefix or Run No., N=Not Available

Section: FOUNTAIN (SERIES 10)

Model: MSD2651HES

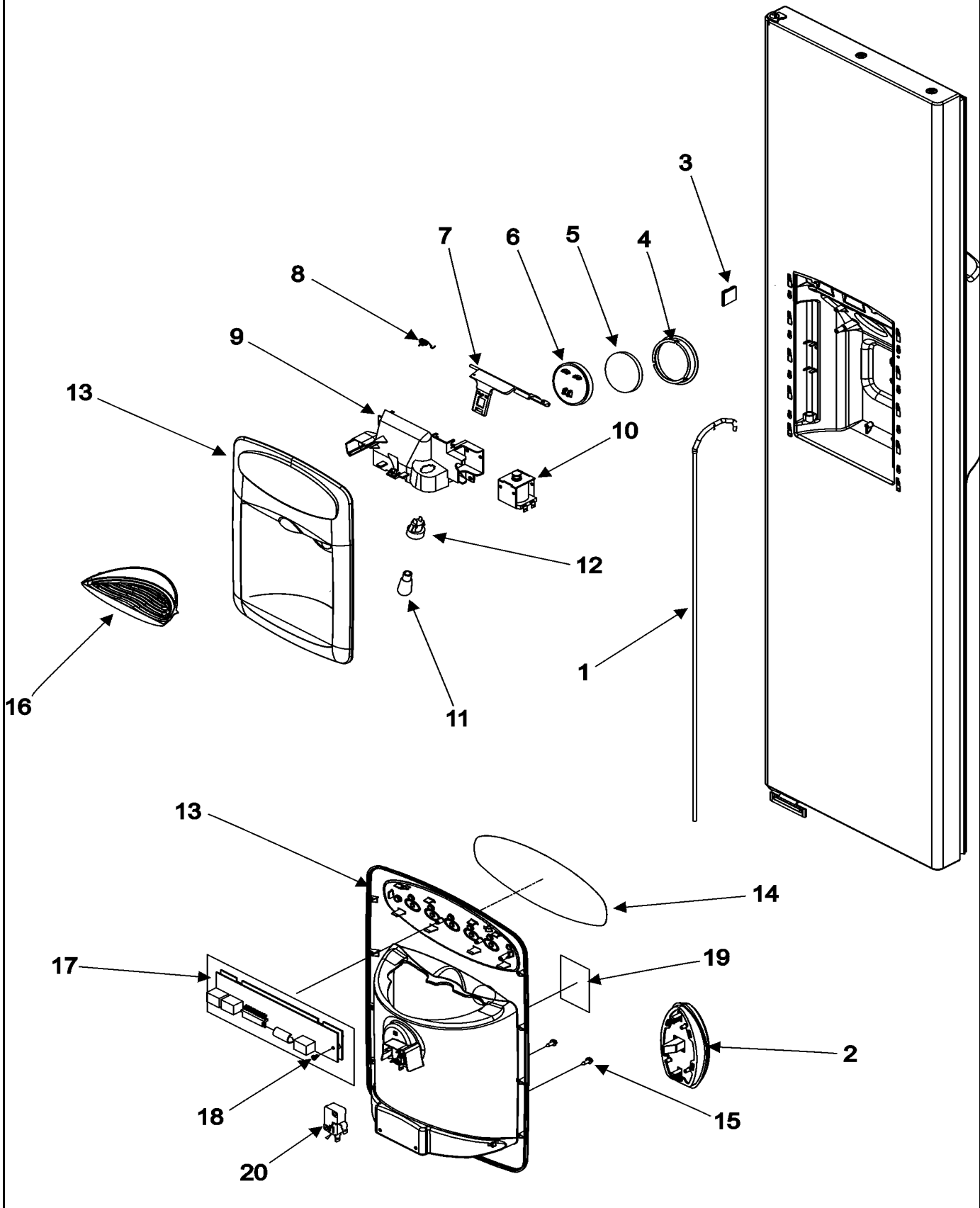

Section: FOUNTAIN (SERIES 10)

No.	Part No.	Description	Series	Qty
-	M0108105	CLAMP, TUBE	10	3
1	67004118	WATERLINE ASSY.	10	1
2	12598902B	ACTR PAD FRAME ASSY. (BLK)	10	1
3	M0104102	CLIP, CORD	10	3
4	12665101	SEAL, ICE CHUTE	10	1
5	12563401	INSUL, CHUTE DOOR**	10	1
6	12562701	DOOR, ICE CHUTE	10	1
7	67004119	HINGE, ICE CHUTE	10	1
8	12565502	SPRING, CHUTE DR	10	1
9	67004120	EXTENSION, ICE CHUTE	10	1
-	M0238642	SCREW, SM Note: SCREW, EXTENSION	10	1
10	12575401	SOLENOID	10	1
-	M0200314	SCREW, MACH Note: SCREW, SOLENOID	10	1
11	67001316	BULB, LIGHT	10	1
12	12617501	SOCKET, LIGHT	10	1
13	67004284	FACADE, 5 BUTTON (BLK)	10	1
14	67004151	INSERT, FACADE (BLK)	10	1
15	M0223230	SCREW, MOUNTING Note: SCREW, FACADE	10	2
16	Y67003722	TRAY, SUMP (BLK)	10	1
17	67003817	BOARD, CONTROL	10	1
18	M0237902	SCREW,HI/LO Note: SCREW, BOARD	10	1
19	67003351	LABEL, DISPENSER	10	1
20	12575501	SWITCH, LIMIT	10	1

*Color Code (-)=Not Shown #=Series, Serial Prefix or Run No., N=Not Available

Section: HINGES & TOE GRILLE (SERIES 10)

Model: MSD2651HES

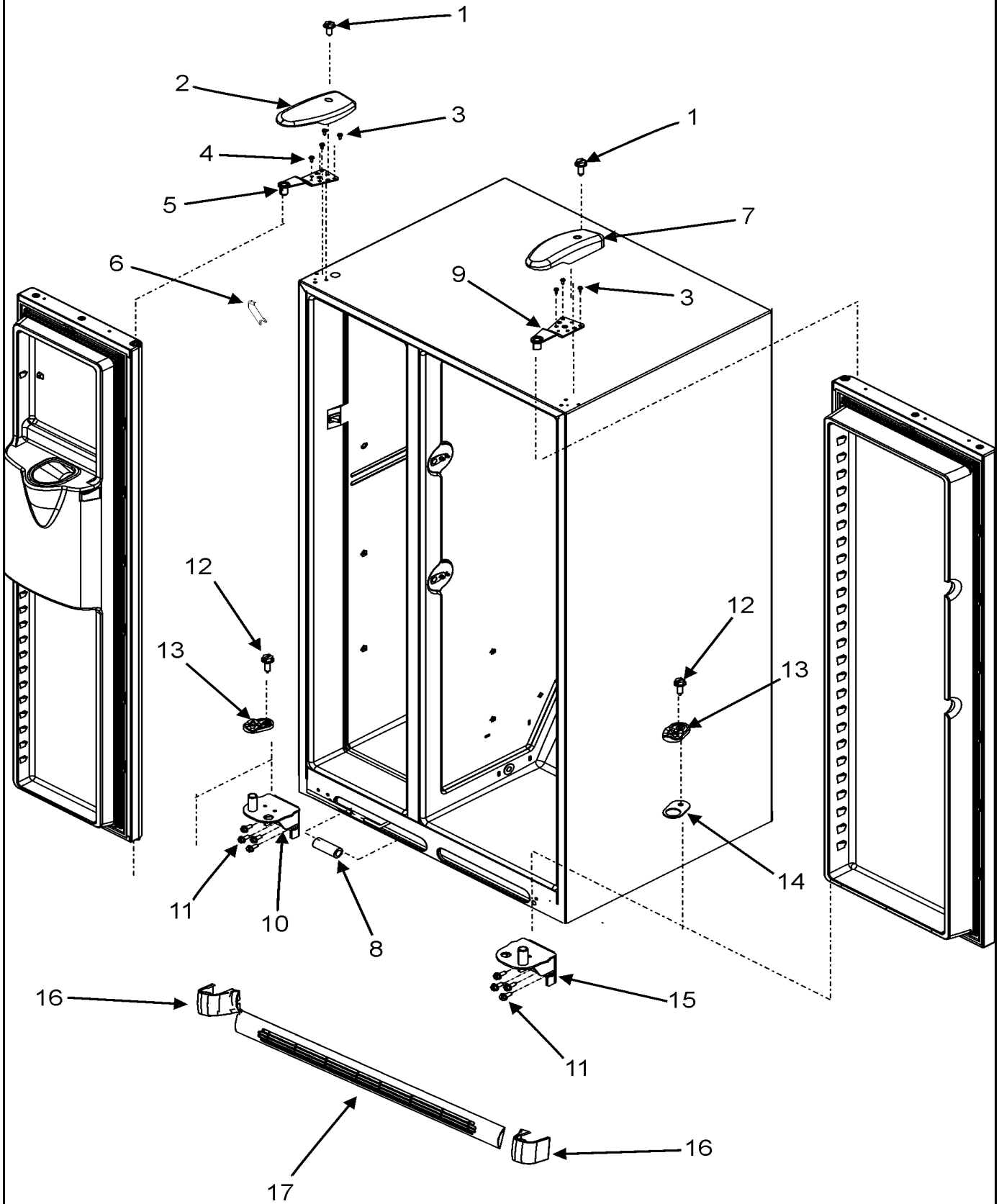

AA54-27

Section: HINGES & TOE GRILLE (SERIES 10)

No.	Part No.	Description	Series	Qty
1	M0202327	SCREW-MACH Note: SCREW, HINGE COVER	10	2
2	67003912	COVER, TOP HINGE (LT-BLK)	10	1
3	M0238731	SCREW, TF Note: SCREW, TOP HINGE	10	6
4	M0202321	SCREW, MACH	10	1
5	67004126	HINGE, TOP (LT-BLK)	10	1
6	67003485	COVER, CORNER (BLK)	10	2
7	67003913	COVER, TOP HINGE (RT-BLK)	10	1
8	61006182	UNION, TUBE (5/16"-5/16")	10	1
9	67004083	HINGE, TOP (RT-BLK)	10	1
10	12636901ED	HINGE, BOTTOM (LT-BLK)	10	1
11	67003858	SCREW, BOTTOM HINGE Note: SCREW, BOTTOM HINGE	10	8
12	M0220431	SCREW, TC Note: SCREW, DOOR CLOSURE	10	2
13	12431302	CLOSURE, DOOR (BLK)	10	2
14	10361806	SHIM, DR CLOSURE (BLK)	10	1
15	12636902ED	HINGE, BOTTOM (RT-BLK)	10	1
16	12630301B	COVER, LWR HINGE (BLK)	10	2
-	12627302	CLIP, TOE GRILLE	10	2
17	67002224	GRILLE ASSY., TOE (BLK) Note: (INCL. CLIPS)	10	1

*Color Code (-)=Not Shown #=Series, Serial Prefix or Run No., N=Not Available

Section: CONTROLS (SERIES 10)

Model: MSD2651HES

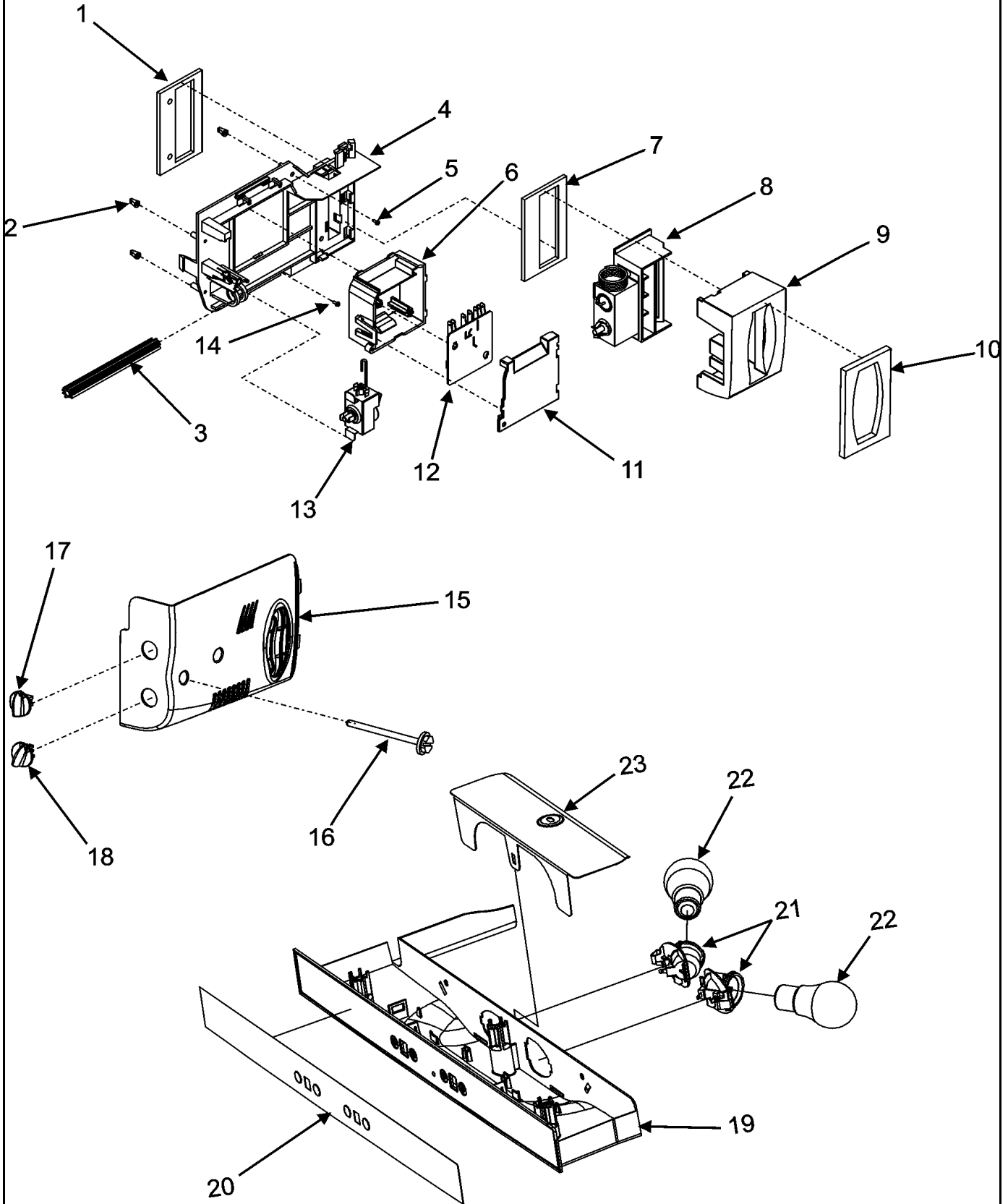

AA50-23

Section: CONTROLS (SERIES 10)

No.	Part No.	Description	Series	Qty
1	67004031	GASKET, DAMPER	10	1
2	M0580205	GROMMET, SCREW	10	3
3	N 12571801	EXTENSION, KNOB	10	1
4	67002981	BRACKET, CONTROL	10	1
5	N M0216539	SCREW Note: SCREW, BRACKET	10	1
6	12624801	BOX, DEFROST CONTROL	10	1
7	12582801	GASKET, DAMPER	10	1
8	12571701	CONTROL, DAMPER	10	1
9	12604201	INSULATION, DAMPER	10	1
10	12582901	GASKET, CONTROL COVER	10	1
11	12624901	COVER, DEFROST CONTROL	10	1
12	67003375	BOARD, ADAPTIVE DEFROST	10	1
13	67003815	CONTROL, FZ TEMP	10	1
14	M0211018	SCREW, SM Note: SCREW	10	1
15	67004158	COVER, CONTROL	10	1
16	M0231426	SCREW Note: SCREW, CONTROL COVER	10	1
17	12581101	KNOB, CONTROL	10	1
18	12581102	KNOB, CONTROL	10	1
-	M0238636	SCREW-SM Note: SCREW, HOUSING	10	3
19	67004240	HOUSING, FZ CONTROL	10	1
20	67004241	OVERLAY	10	1
21	12570701	SOCKET, LIGHT	10	2
22	67003568	BULB, LIGHT (40 WATT)	10	2
23	67004157	REFLECTOR, LIGHT	10	1
-	67004154	HARNESS, CONTROL	10	1

*Color Code (-)=Not Shown #=Series, Serial Prefix or Run No., N=Not Available

Section: REFRIGERATOR SHELVES (SERIES 10)

Model: MSD2651HES

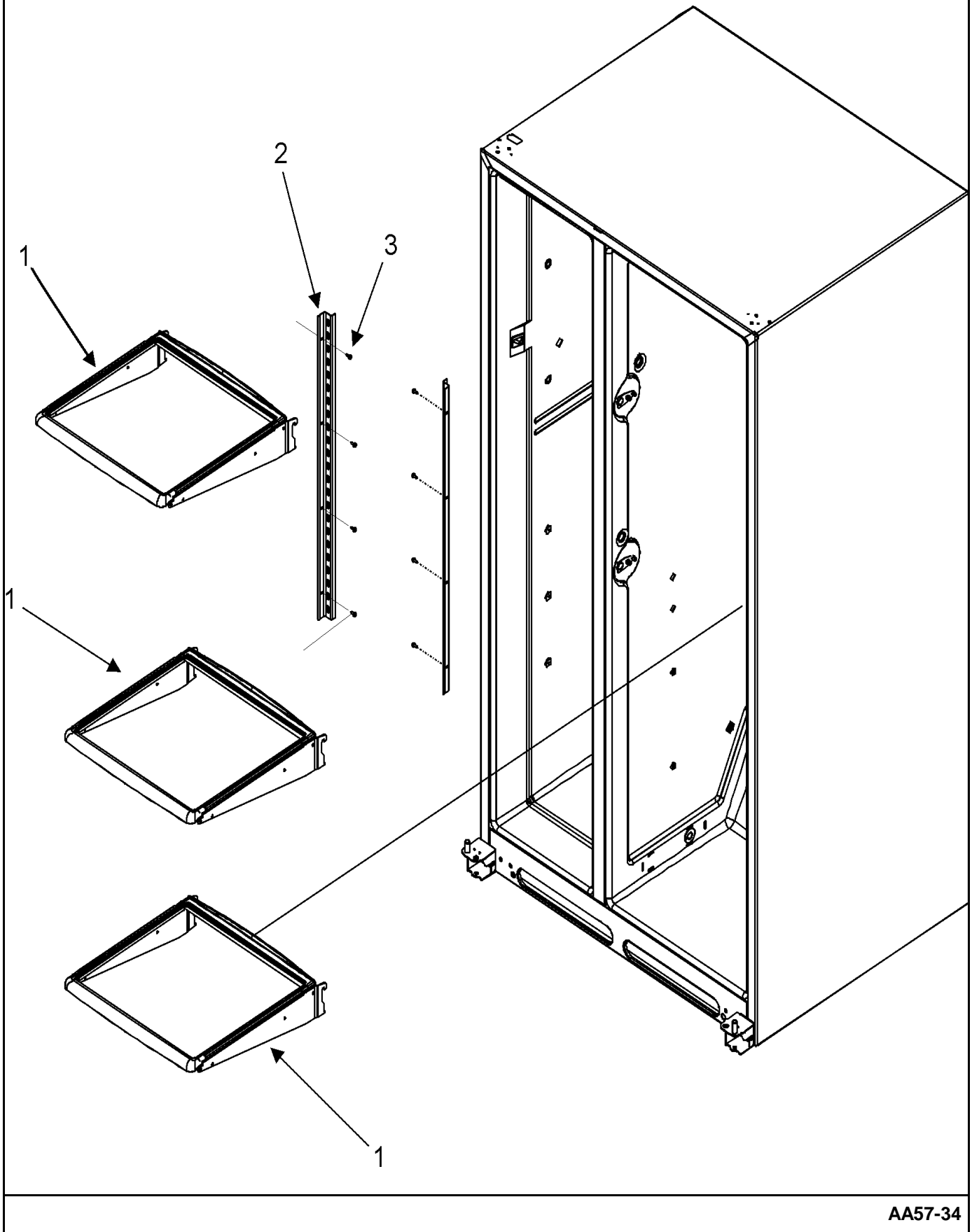

AA57-34

Section: REFRIGERATOR SHELVES (SERIES 10)

No.	Part No.	Description	Series	Qty
1	67004348	SHELF, STATIONARY	10	3
2	67003839	RAIL, L/R SM SXS	10	2
3	M0211016	SCREW, SM Note: SCREW, LADDER	10	6

*Color Code (-)=Not Shown #=Series, Serial Prefix or Run No., N=Not Available

Section: FREEZER SHELVES (SERIES 10)

Model: MSD2651HES

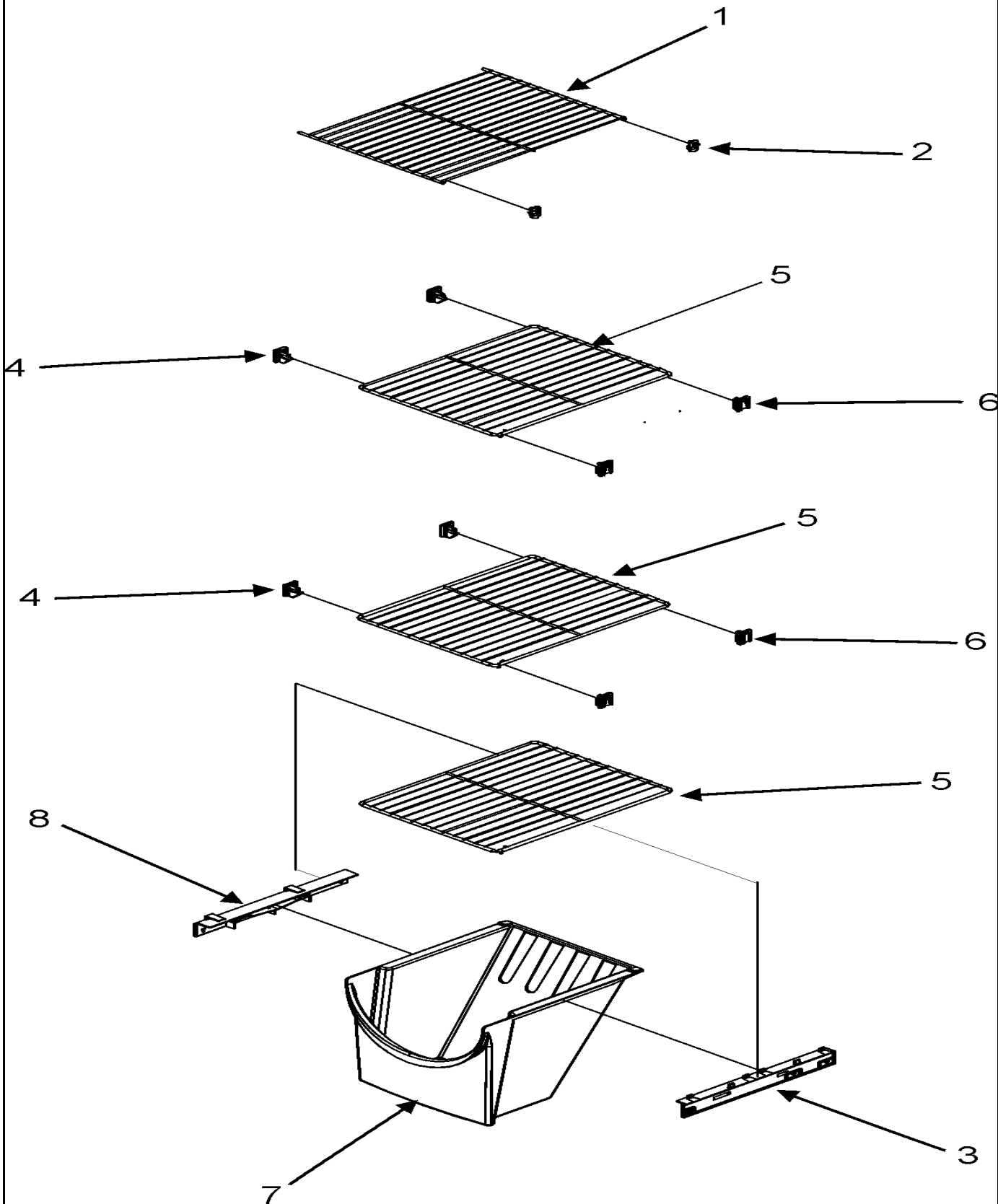

Section: FREEZER SHELVES (SERIES 10)

No.	Part No.	Description	Series	Qty
1	67004354	SHELF, UPR FRZ.	10	1
2	C8973801	SUPPORT, FRZ SHELF	10	2
3	67004356	RAIL, BIN (RT)	10	1
4	12015002	SUPPORT, SHELF (LT)	10	4
5	67004250	SHELF, LWR FZ	10	3
6	10941102	SUPPORT, SHELF (RT)	10	4
7	12596501	BIN, FZ	10	1
8	67004355	RAIL, BIN (LT)	10	1

*Color Code (-)=Not Shown #=Series, Serial Prefix or Run No., N=Not Available

Section: EVAP FAN/CRISP LIGHT/FILTER (SER.10)

Model: MSD2651HES

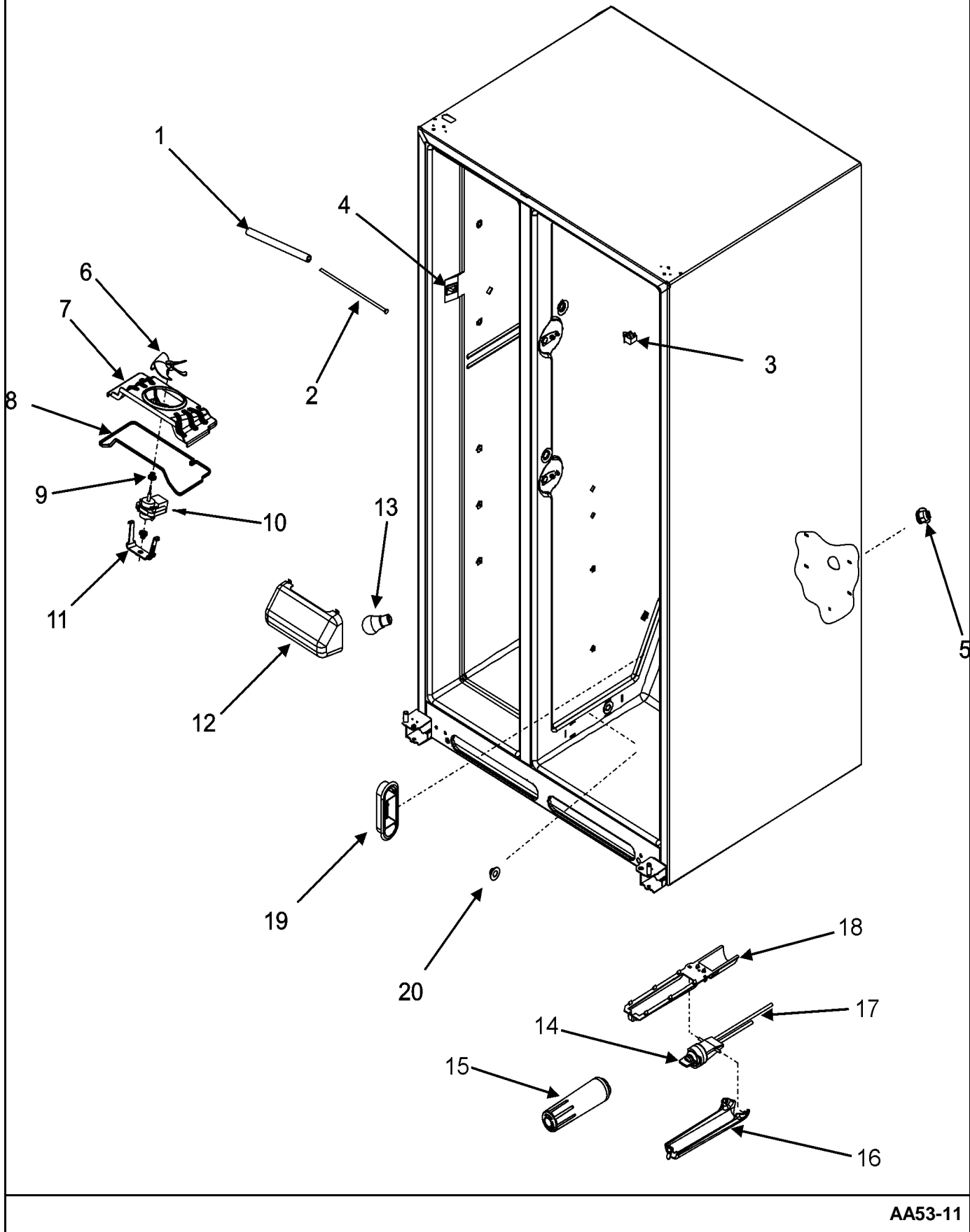

AA53-11

Section: EVAP FAN/CRISP LIGHT/FILTER (SER.10)

No.	Part No.	Description	Series	Qty
1	67004185	INSULATION, TUBING	10	1
2	67004186	TUBE, PLASTIC	10	1
3	12466104	SWITCH, REF LIGHT	10	1
4	12466103	SWITCH, LIGHT	10	1
5	12570701	SOCKET, LIGHT	10	1
6	12217201	FAN, EVAPORATOR	10	1
7	67004253	SHROUD, EVAP	10	1
8	67001508	GASKET Note: GASKET, SHROUD	10	1
9	67002780	GROMMET, FAN MOTOR (BLK)	10	2
10	67003636	MOTOR, EVAP FAN	10	1
11	67003083	CLIP Note: CLIP, EVAP MOTOR	10	1
12	67001507	SHIELD, CRISPER LIGHT	10	1
13	67003568	BULB, LIGHT (40 WATT)	10	1
14	67003146	PLUG, BYPASS Note: PLUG, BYPASS	10	1
15	67003591	FILTER, WATER SINGLE Note: FILTER, WATER	10	1
16	12568001	COVER, FILTER	10	1
17	67004106	HEAD, WATER FILTER (W/TUBING)	10	1
18	12688503	PLATE, FILTER BACKING	10	1
19	12634801	GRILLE, RETURN AIR	10	1
20	67003018	PLUG, AIR TUNNEL	10	1

*Color Code (-)=Not Shown #=Series, Serial Prefix or Run No., N=Not Available

Section: EVAPORATOR/ROLLERS/WATER TANK (SER.10)

Model: MSD2651HES

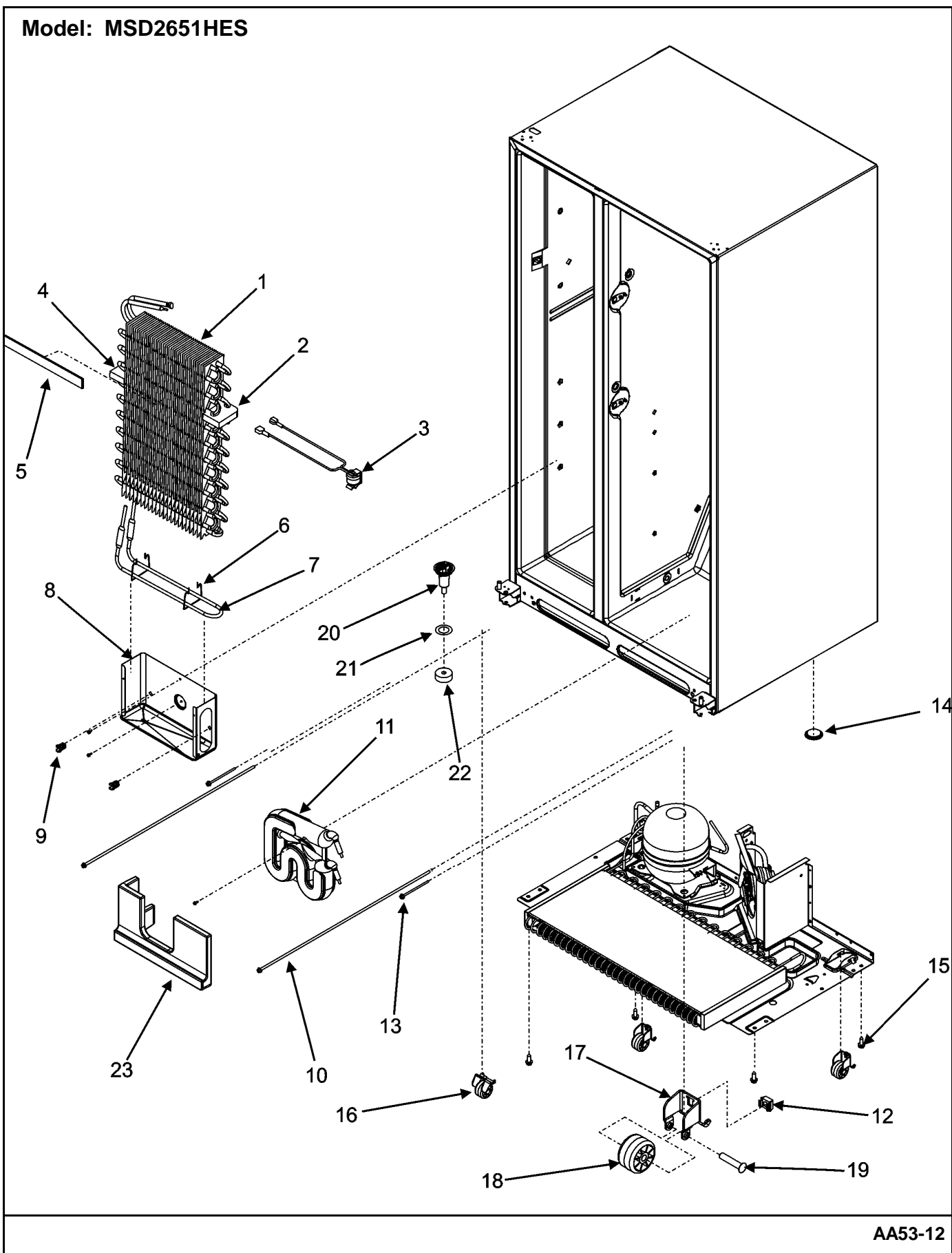

AA53-12

Section: EVAPORATOR/ROLLERS/WATER TANK (SE

No.	Part No.	Description	Series	Qty
1	12001940	EVAP KIT (SXS)--W	10	1
2	12590102	BLOCK, AIR COIL (RT)	10	1
3	67003964	THERMOSTAT, DEFROST	10	1
4	12590101	BLOCK, AIR COIL (LT)	10	1
5	67002226	GASKET, FOAM	10	1
6	10428101	CLIP, EVAP HEATER	10	2
7	67004188	HEATER, EVAP	10	1
-	M0224416	SCREW, SM Note: SCREW, TRAY	10	2
8	12558101WD	TRAY, EVAP DRIP	10	1
9	10623003	CLIP, EVAPORATOR	10	2
10	10093313	SCREW, ADJUSTING	10	2
-	M0211018	SCREW, SM Note: SCREW, TANK	10	1
11	67003504	TANK, WATER	10	1
12	M0286708	NUT, SPEED	10	4
13	12606102	BOLT, ROLLER ADJ	10	2
14	A3076901	PLUG, BUTTON	10	1
15	67001510	SCREW	10	4
16	67002227	ROLLER BRACKET ASSY	10	4
17	12456801	BRACKET, ROLLER	10	4
18	10450602	ROLLER	10	4
19	M1205302	RIVET	10	4
20	12456901	FUNNEL, DRAIN	10	1
21	M0500703	SEAL, O RING	10	1
22	B8381501	GASKET, DRAIN TUBE	10	1
23	67004309	BLOCK, WATER TANK	10	1
-	67004189	HEATER/HARNESS, FRZ	10	1

*Color Code (-)=Not Shown #=Series, Serial Prefix or Run No., N=Not Available

Section: FREEZER COMPARTMENT (SERIES 10)

Model: MSD2651HES

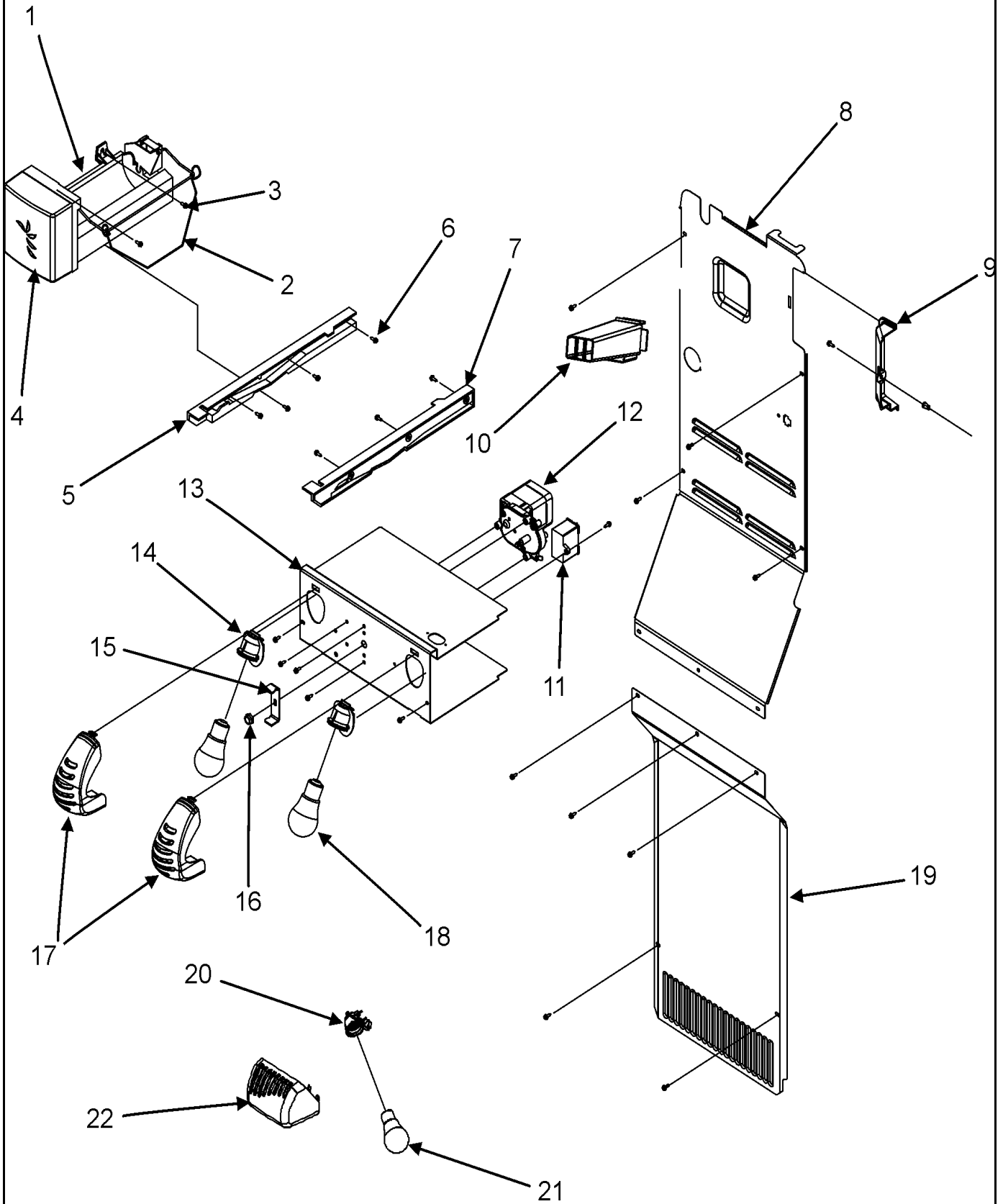

AA53-10

Section: FREEZER COMPARTMENT (SERIES 10)

No.	Part No.	Description	Series	Qty
1	61005508	ICE MAKER ASSY.	10	1
-	67002823	BRKT, ICE MAKER	10	1
2	12671401	ASSY, IM ARM/WIRE	10	1
3	M0211019	SCREW, SM Note: SCREW, ICE MAKER	10	2
4	12582501	COVER, ICE MAKER	10	1
5	67004322	GLIDE, FRZ. (LT)	10	1
6	M0213530	SCREW, SM (STNLS) Note: SCREW, GLIDE (STNLS)	10	7
7	67004323	GLIDE, FRZ. (RT)	10	1
8	67003577	BACK INNER FZ 26 Note: BACK, INNER FZ	10	1
-	M0238616	SCREW, SM Note: SCREW, BACK	10	4
-	M0580205	GROMMET, SCREW	10	1
-	M0238616	SCREW, SM Note: SCREW, COVER	10	1
9	12583101	COVER, SUPPLY AIR	10	1
10	67003578	DUCT, QUICK ICE 26	10	1
11	C8931612	CAPACITOR	10	1
-	M0226528	SCREW, TC Note: SCREW, CAPACITOR	10	1
-	M0226528	SCREW, TC Note: SCREW, MOTOR	10	3
12	67003226	MOTOR, AUGER	10	1
13	12561701	COVER, AUGER MOTOR	10	1
-	M0238616	SCREW, SM Note: SCREW, COVER	10	2
14	12570701	SOCKET, LIGHT	10	2
15	10114901	DRIVER (ICE MAKER)	10	1
16	M0223101	NUT, LOCKING	10	1
17	67004433	SHIELD, FZ LIGHT	10	2
18	67003568	BULB, LIGHT (40 WATT)	10	2
19	67004192	COVER, EVAP	10	1
-	M0238616	SCREW, SM Note: SCREW, COVER	10	5
20	12570701	SOCKET, LIGHT	10	1
21	67003568	BULB, LIGHT (40 WATT)	10	1
22	67004135	SHIELD, FZ LIGHT	10	1

*Color Code (-)=Not Shown #=Series, Serial Prefix or Run No., N=Not Available

Section: COMPRESSOR (SERIES 10)

Model: MSD2651HES

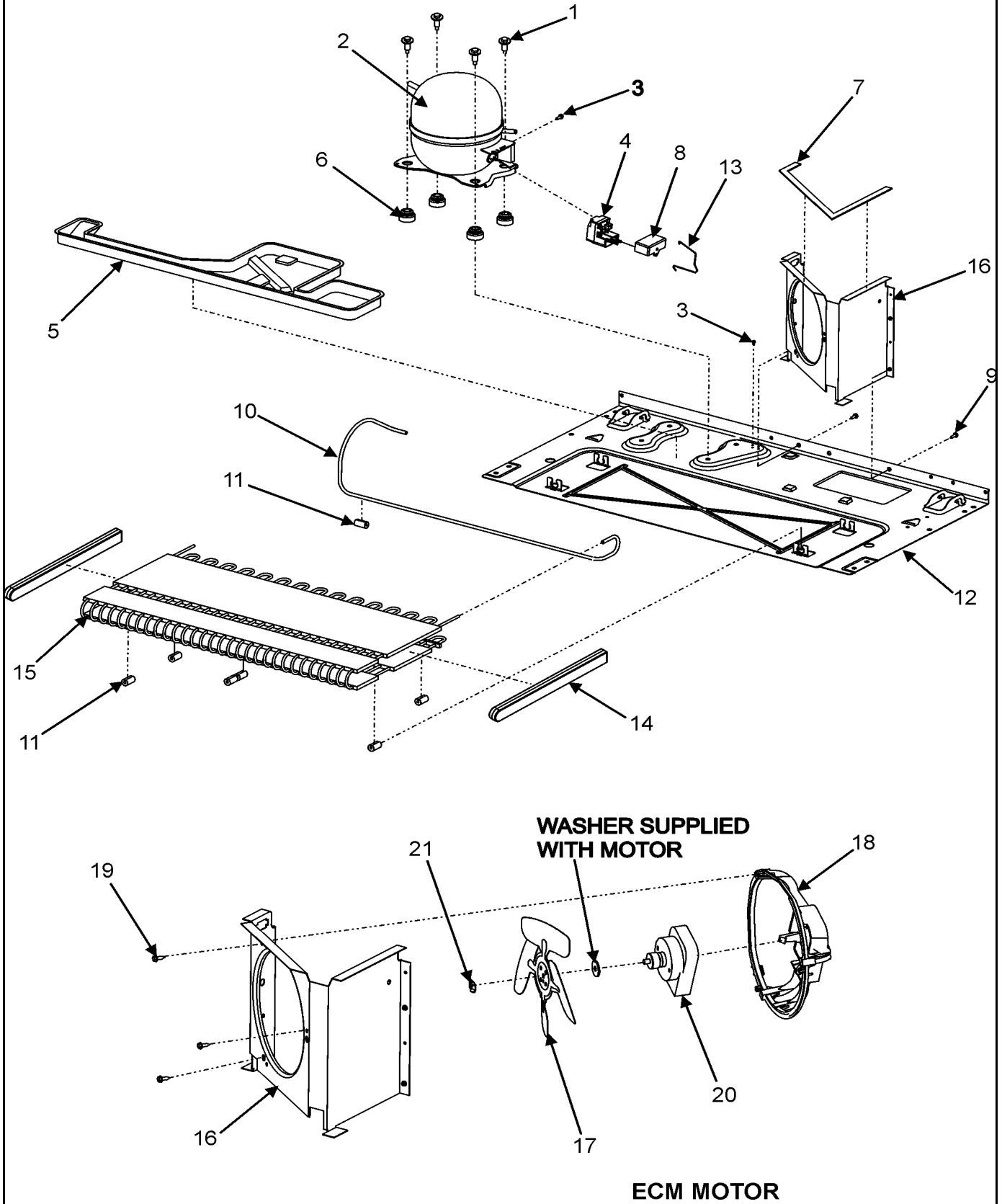

AA51-13

Section: COMPRESSOR (SERIES 10)

No.	Part No.	Description	Series	Qty
1	N M0221523	SCREW, SHLDR Note: SCREW, COMPRESSOR	10	3
2	67002782	COMPRESSOR, TPG1380YXA (SXS)	10	1
3	M0231604	SCREW, TF Note: SCREW	10	2
4	67003764	OVERLOAD/RELAY W/CAPACITOR	10	1
5	67004464	PAN, DRAIN	10	1
6	67003493	GROMMET, COMPRESSOR	10	4
7	61003210	SEAL	10	1
8	C8931612	CAPACITOR	10	1
9	M0238616	SCREW, SM Note: SCREW	10	3
10	67004700	TUBE, DISCHARGE	10	1
11	12578601	GROMMET, CONDENSER	10	8
12	67001512	PAN, BASE	10	1
13	12576801	STRAP, BALE	10	1
14	67002235	BLOCK-EPS COND	10	2
15	67004682	CONDENSER *	10	1
16	67001090	SHROUD, CONDENSER FAN	10	1
17	12587601	BLADE, COND FAN	10	1
18	67003644	BRKT, ECM COND MOTOR	10	1
19	M0223816	SCREW, TR Note: SCREW, BRACKET	10	3
20	12628701	MOTOR, CONDENSER FAN (ECM)	10	1
21	12632601	NUT, ECM MOTOR	10	1
-	67004097	HARNES, MC	10	1

*Color Code (-)=Not Shown #=Series, Serial Prefix or Run No., N=Not Available

Section: CABINET BACK (SERIES 10)

Model: MSD2651HES

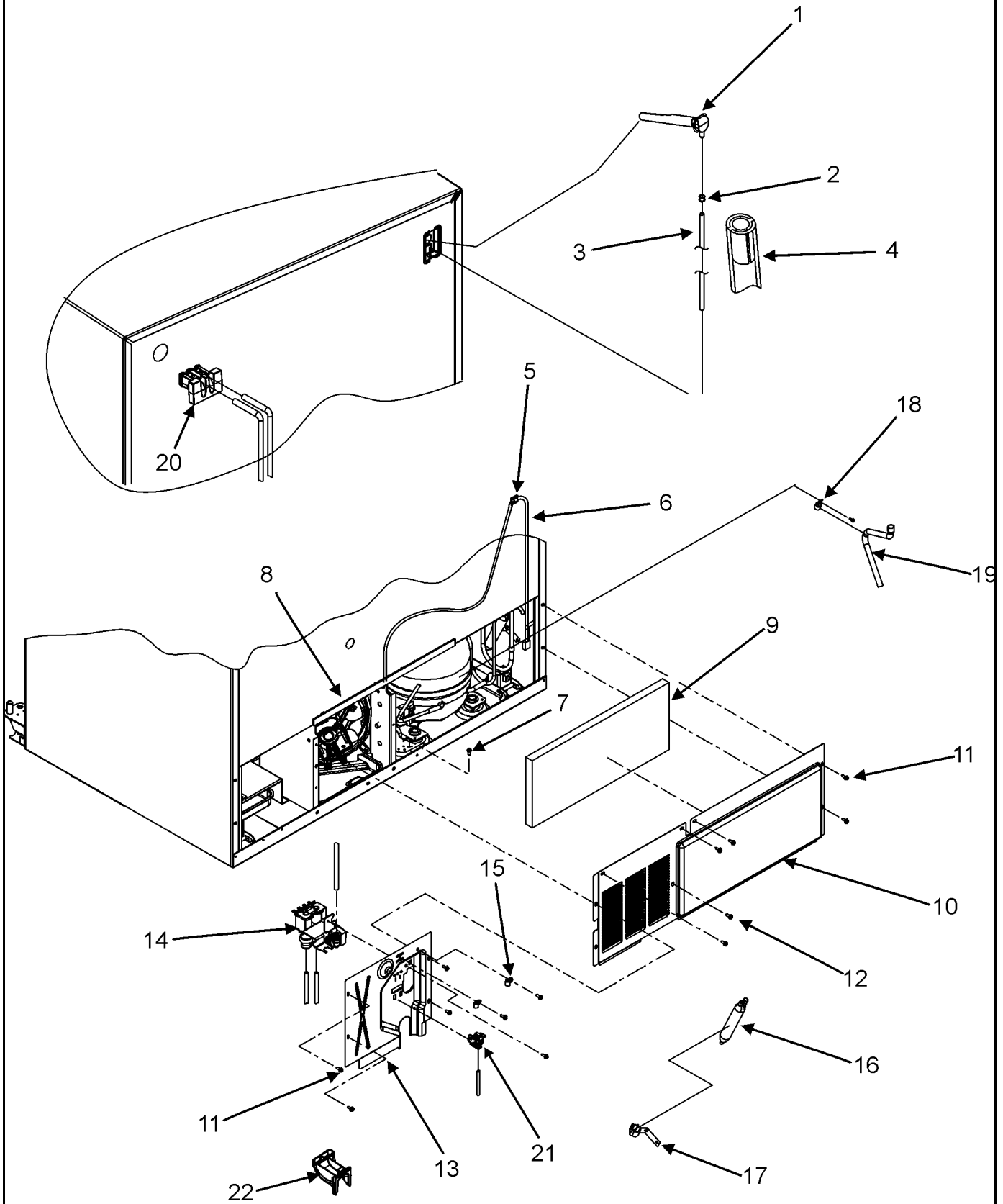

AA56-50

Section: CABINET BACK (SERIES 10)

No.	Part No.	Description	Series	Qty
1	67003576	ELBOW, FILL TUBE	10	1
2	M0114003	CLIP, SPEED	10	1
3	67003360	TUBE, PLASTIC	10	1
4	A3223101	INSERT, PLASTIC TUBE	10	1
5	M0104106	CLIP	10	1
6	12583301	CORD, POWER	10	1
7	N M0239216	SCREW, CA Note: SCREW	10	1
8	B5759649	GASKET, MC BACK	10	1
9	67003796	FIBER, ACOUSTIC	10	1
10	12575101ED	BACK, MACH COMP	10	1
11	M0238616	SCREW, SM Note: SCREW, COVER	10	11
12	M0251015	SCREW	10	1
13	67004098	COVER, WATER VALVE	10	1
14	67003818	VALVE, DUAL WATER	10	1
-	M0251015	SCREW Note: SCREW, VALVE	10	1
15	M0108105	CLAMP, TUBE	10	2
16	B2150504	DRIER	10	1
-	67002999	SCREW, SM Note: SCREW, CLIP	10	1
17	10547002	CLIP, DRIER	10	1
-	M0220617	SCREW Note: SCREW, CLAMP	10	1
18	M0102303	CLAMP	10	1
19	12580401	TUBE, DRAIN	10	1
20	67004092	BLOCK, FILTER	10	1
21	67004100	CLIP, WATERLINE	10	1
22	67004101	SWEEP, DUAL TUBE	10	1
-	67004102	TRACK, WATERLINE	10	1

*Color Code (-)=Not Shown #=Series, Serial Prefix or Run No., N=Not Available

Section: ICE MAKER (SERIES 10)

Model: MSD2651HES

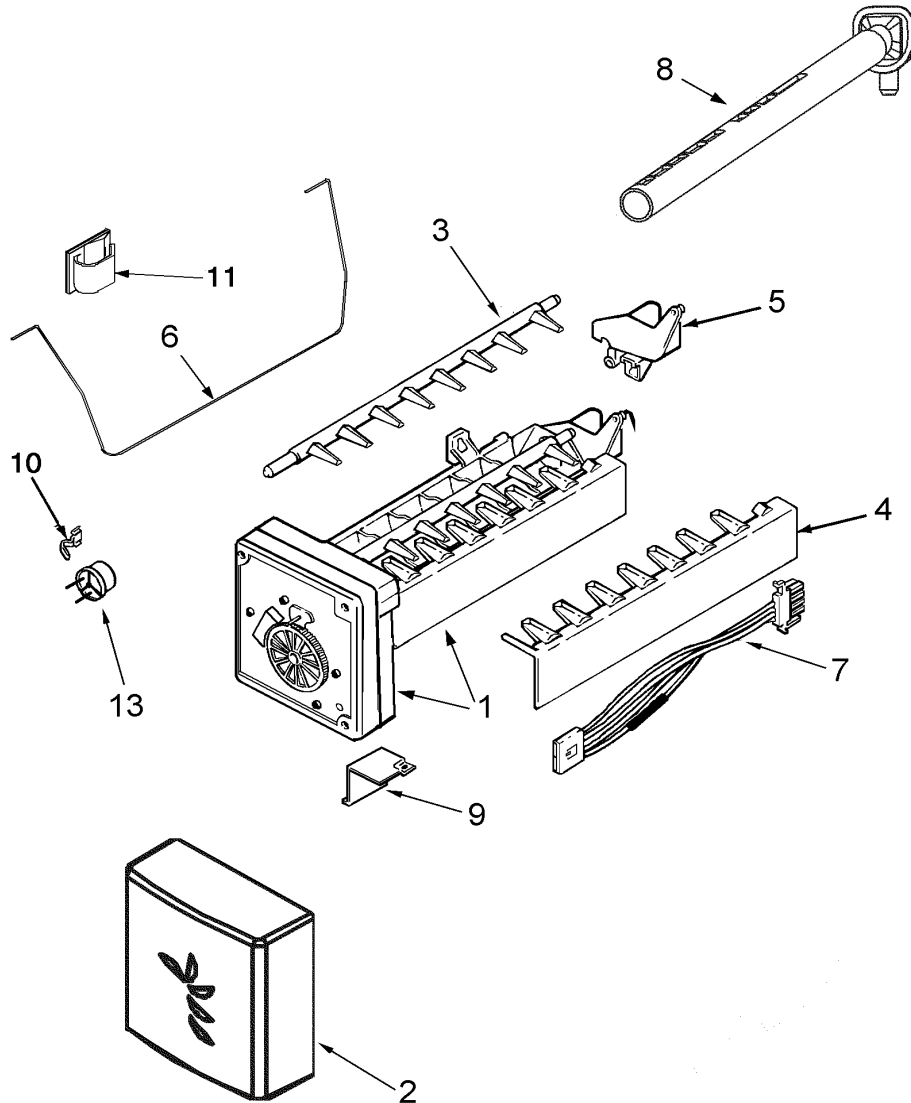

Section: ICE MAKER (SERIES 10)

No.	Part No.	Description	Series	Qty
-	67002823	BRKT, ICE MAKER	10	1
-	M0211019	SCREW, SM Note: SCREW, ICE MAKER	10	2
1	61005508	ICE MAKER ASSY.	10	1
2	12582501	COVER, ICE MAKER	10	1
3	95101-1	EJECTOR, ICE	10	1
4	95102-1	STRIPPER, ICE	10	1
5	95100-1	INLET, WATER	10	1
6	12671401Q	IM ARM/WIRE ASSY	10	1
7	67002124	HARNESS, ICE MAKER	10	1
8	67003576	ELBOW, FILL TUBE	10	1
-	95108-1	SCREW, BRACKET	10	1
9	95107-1	BRACKET, MODULE & HEATER	10	1
10	95104-1	RETAINER, THERMOSTAT	10	1
11	M0104106	CLIP	10	2
- N	95093-1	CEMENT, ALUMILASTIC (4 OZ.)	10	1
12	95092-1	THERMOSTAT	10	1
-	10244904	COUPLING	10	1
-	R0131235	ICE MAKER HOOK UP KIT Note: (INCL. 1/4" X 25' COPPER TUBE, NON PIERCING SADDLE VALVE, & 1/4" COMPRESSION NUT & SLEEVE)	10	1

*Color Code (-)=Not Shown #=Series, Serial Prefix or Run No., N=Not Available

Section: ICE BUCKET ASSY. (SERIES 10)

Model: MSD2651HES

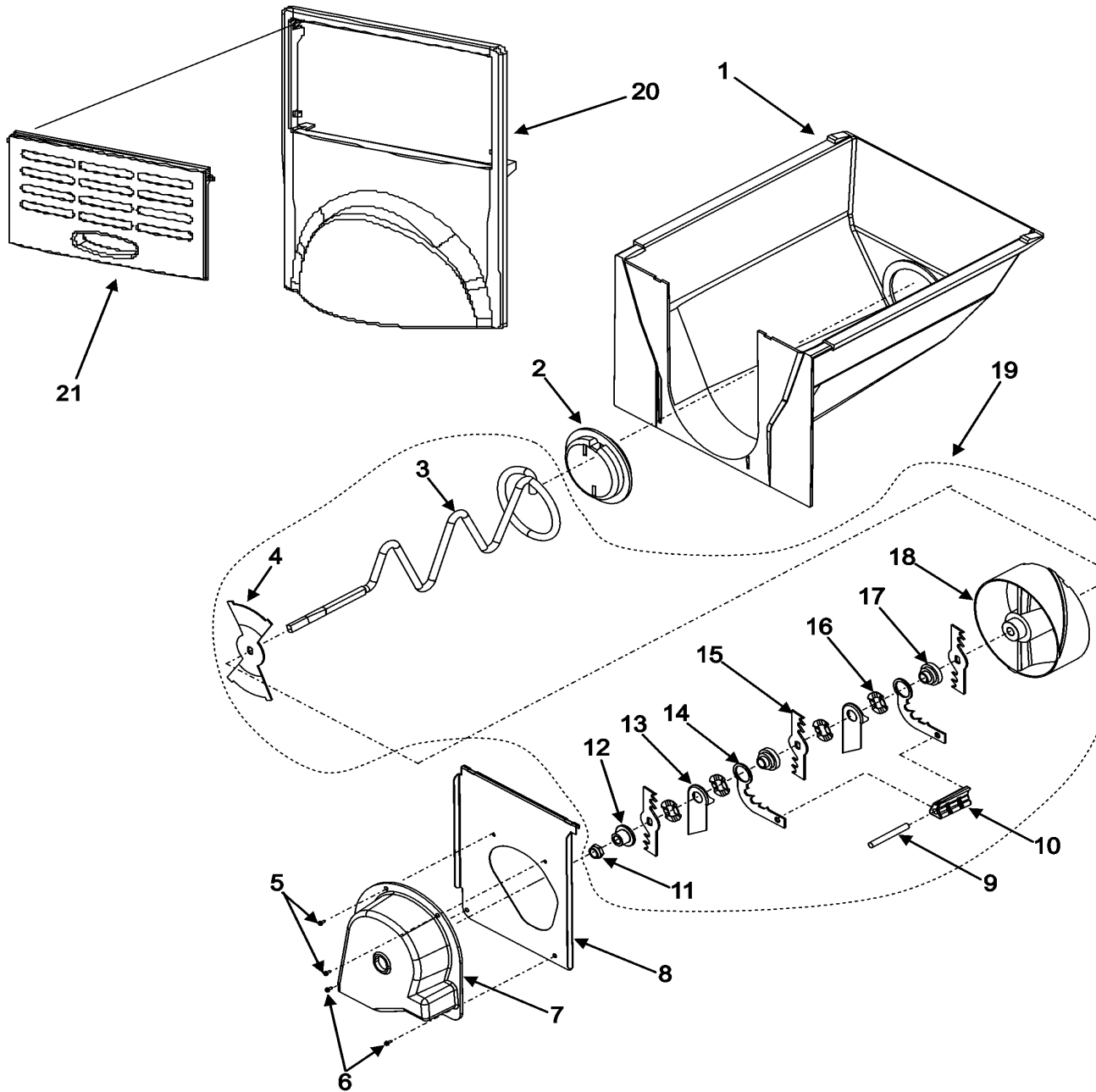

Section: ICE BUCKET ASSY. (SERIES 10)

No.	Part No.	Description	Series	Qty
1	12517801	BUCKET, ICE CRUSH	10	1
2	D7749401	CAP, HELIX END	10	1
3	10114401	AGITATOR, ICE	10	1
4	10113801	BAR, CRSH ICE BUCKET	10	1
5	59001208	SCREW, HEX HEAD	10	2
6	M0238616	SCREW, SM	10	2
7	67002271	COVER, BLADE	10	1
8	10115001	FRONT, ICE CRUSHER	10	1
9	M1200108	PIN, ROLL	10	1
10	10114101	ANCHOR, BLADE	10	1
11	M0223101	NUT, LOCKING	10	1
12	10113901	SPACER, COVER	10	1
13	10275201	DAMPER, ICE	10	2
14	10114601	BLADE, STATIC	10	2
15	10114501	BLADE, ROTATING	10	3
16	10275101	WASHER, WAVED	10	4
17	10114301	WASHER STEPPED	10	2
18	67002052	WHEEL, CRSH ICE	10	1
19	67003350	CRUSHED ICE AGITATOR ASSY	10	1
20	67004255	COVER, ICE BUCKET	10	1
21	67004256	DOOR, ICE BUCKET	10	1

*Color Code (-)=Not Shown #=Series, Serial Prefix or Run No., N=Not Available

Section: SUPPLEMENTAL INFORMATION (SERIES 10)

Model: MSD2651HES

No image available

NOIMAGE

Section: SUPPLEMENTAL INFORMATION (SERIES 10)

No.	Part No.	Description	Series	Qty
-	12842103	MANUAL, USE & CARE	10	1
-	16023088	TECH SHT, SXS	10	1
-	67004860	TAG, ENERGY	10	1
-	16022689	SVC MAN, SXS	10	1

*Color Code (-)=Not Shown #=Series, Serial Prefix or Run No., N=Not Available

Section: CRISPER ASSEMBLY (SERIES 10)

Model: MSD2651HES

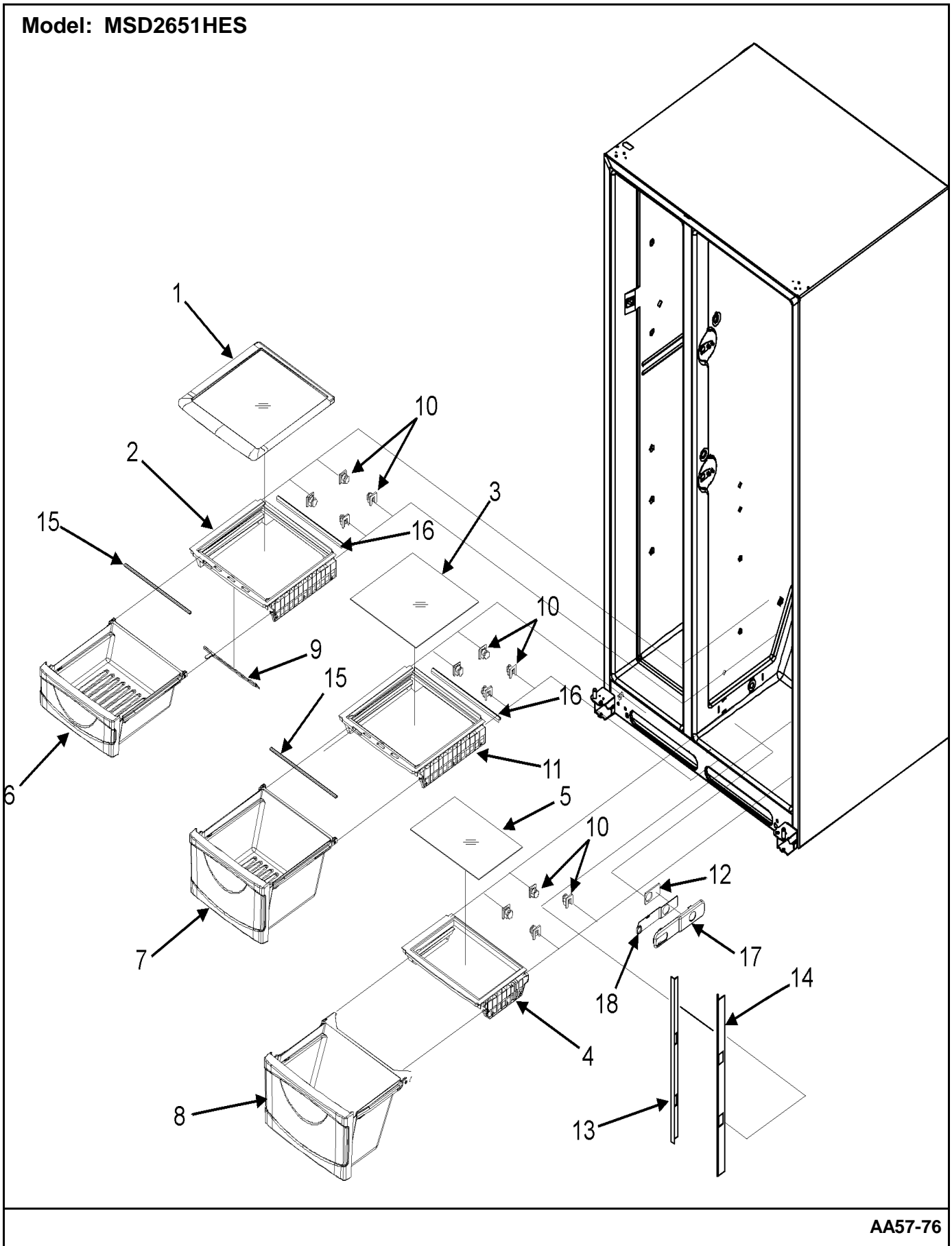

AA57-76

Section: CRISPER ASSEMBLY (SERIES 10)

No.	Part No.	Description	Series	Qty
1	67004130	SHELF, CRISPER TOP	10	1
2	67004352	FRAME, LG CRISPER SHELF Note: FRAME, SM CRISPER SHELF	10	1
3	67004246	GLASS, CRISPER SHELF	10	1
4	67004247	FRAME, MEAT SHELF	10	1
5	67004132	GLASS, MEAT SHELF	10	1
6	67004349	PAN ASSY., SM CRISPER	10	1
7	67004350	PAN ASSY., LG CRISPER	10	1
8	67004351	PAN ASSY., MEAT	10	1
9	67004168	SLIDE, CONTROL	10	1
10	12603701	SUPPORT, CRISPER FRAME	10	12
11	67004140	FRAME, CRISPER SHELF	10	1
12	67004177	GASKET, TEMP. CONTROL	10	1
13	67004170	PILLAR (LT)	10	1
14	67004171	PILLAR (RT)	10	1
15	67004248	SEAL, CRISPER FRAME (FRT)	10	2
16	67004249	SEAL, CRISPER FRAME (REAR)	10	2
17	67004175	HOUSING, TEMP. CONTROL	10	1
18	67004176	SLIDE, TEMP. CONTROL	10	1

*Color Code (-)=Not Shown #=Series, Serial Prefix or Run No., N=Not Available

Section: WIRING INFORMATION (SERIES 10)

Model: MSD2651HES

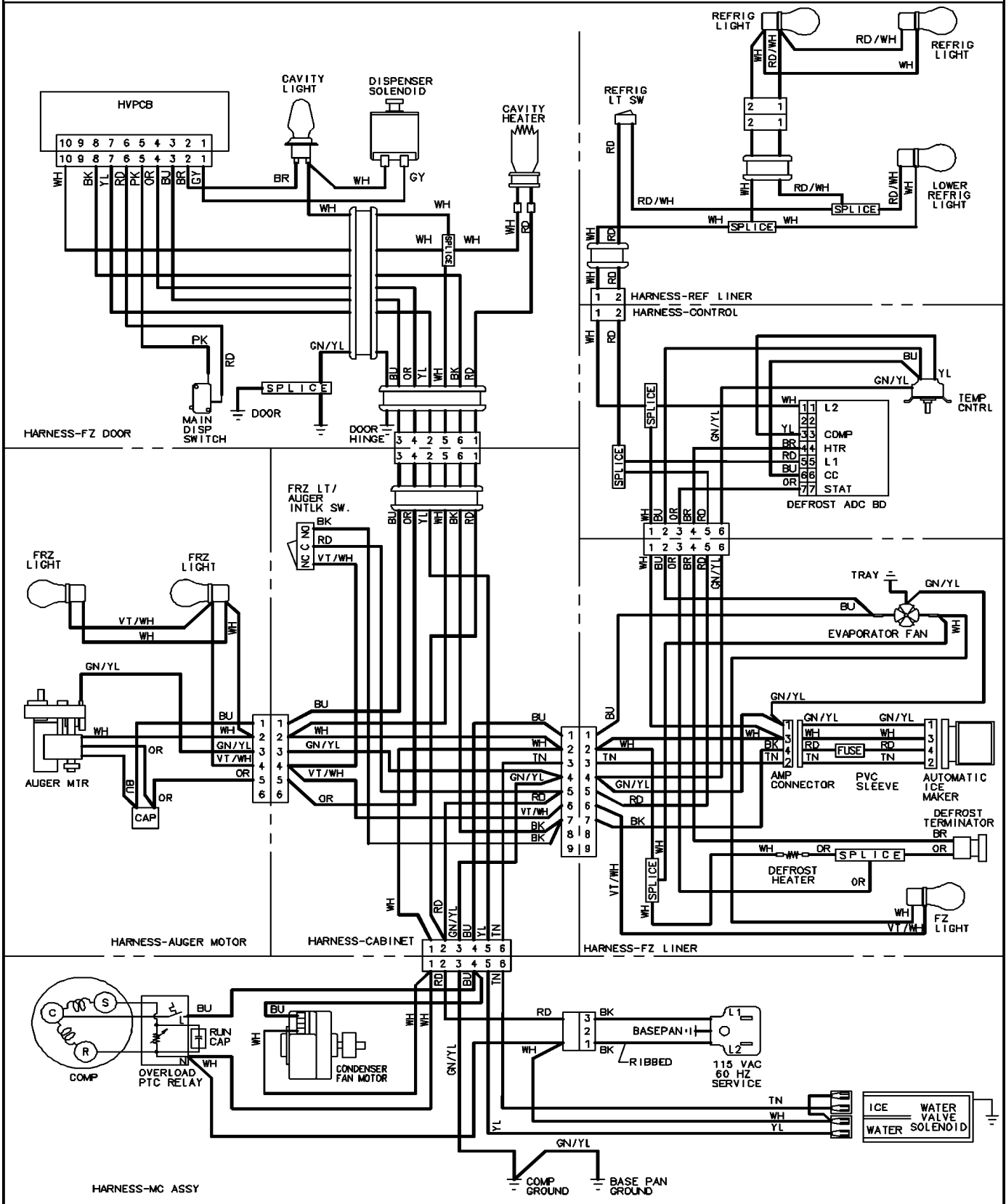

15003523

Section: WIRING INFORMATION (SERIES 10)

No.	Part No.	Description	Series Qty
-	N 15003523	WIRING INFORMATION	10 1

*Color Code (-)=Not Shown #=Series, Serial Prefix or Run No., N=Not Available

Section: REFRIGERATOR DOOR (SERIES 50)

Model: MSD2651HES

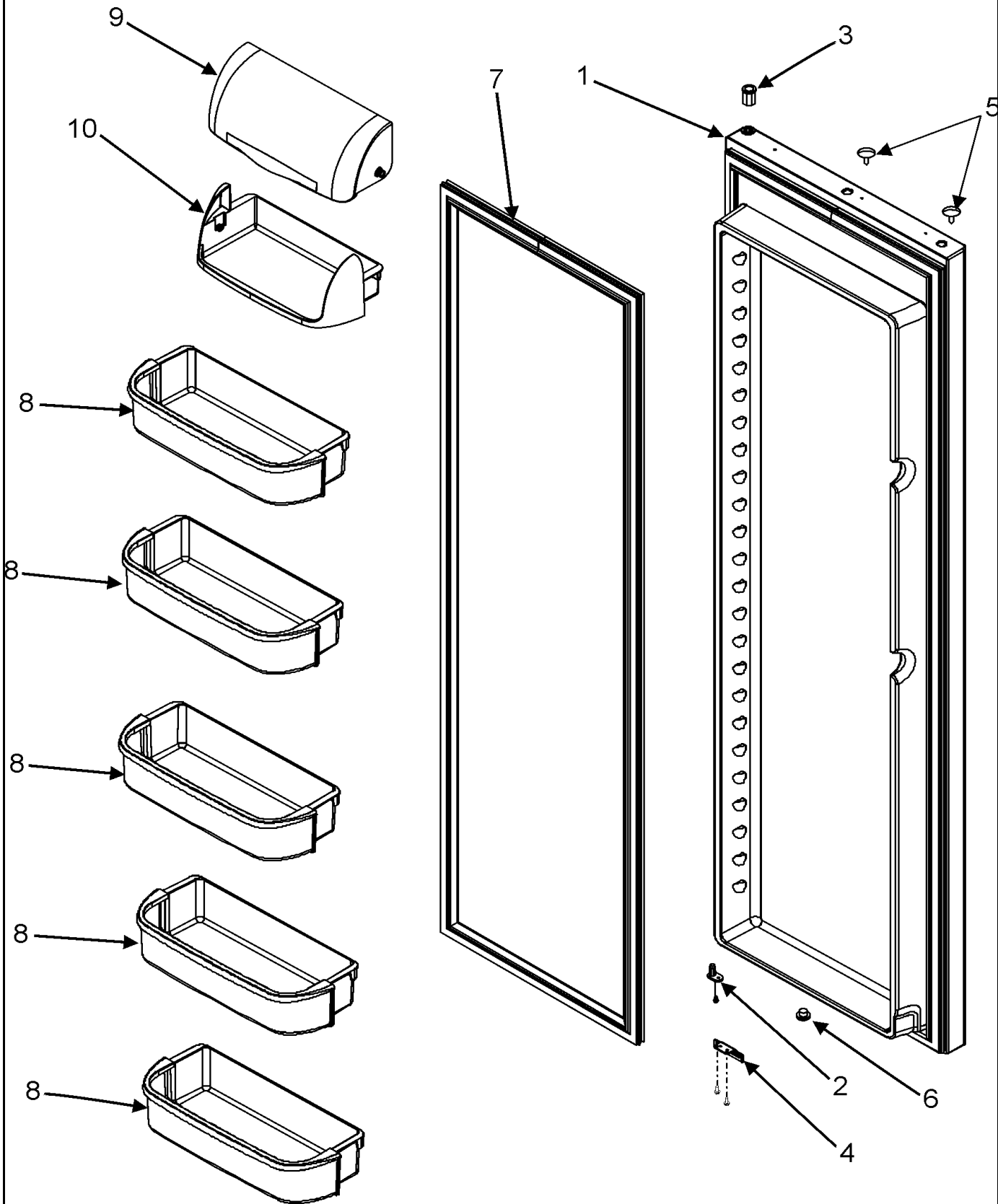

AA54-53

Section: REFRIGERATOR DOOR (SERIES 50)

No.	Part No.	Description	Series	Qty
1	67004909	DOOR ASSY., REF. FOAM (STNLS)	50	1
-	W10124350	NOT REQUIRED PART OR SEE NOTE Note: SCREW-NOT REQUIRED PART	53	0
2	12113204	CLOSURE, DOOR (BLK)	50	1
-	M0220432	SCREW, TC Note: SCREW, CLOSURE	50	1
3	10961002	BUSHING, DOOR (BLK)	50	1
-	M0211018	SCREW, SM Note: SCREW, DOOR STOP	50	2
4	12636401B	STOP, DOOR (BLK)	50	1
5	M0311607	PLUG, BUTTON (GRY)	50	2
6	A3080001	PLUG, BUTTON (BLK)	50	1
7	67003965	GASKET, REF. DOOR (BLK)	50	1
8	67004110	BUCKET-36"REF GAL	50	5
9	67001325	DOOR, DAIRY	50	1
10	67002304	TRAY, DAIRY	50	1

*Color Code (-)=Not Shown #=Series, Serial Prefix or Run No., N=Not Available

Section: FREEZER DOOR (SERIES 50)

Model: MSD2651HES

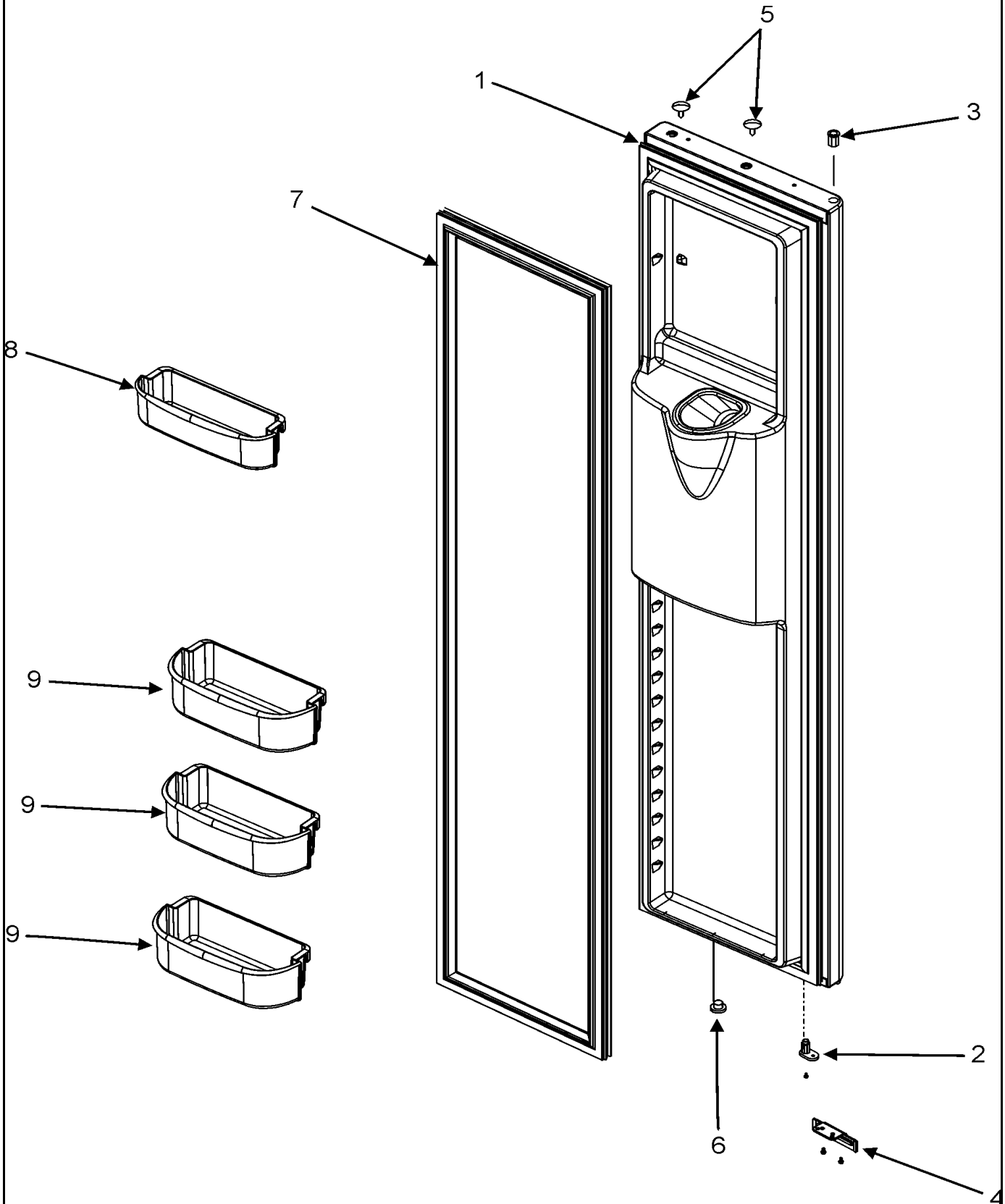

AA55-12

Section: FREEZER DOOR (SERIES 50)

No.	Part No.	Description	Series	Qty
1	67003989	DOOR ASSY., FRZ. FOAM (STNLS)	50	1
-	M0220432	SCREW, TC Note: SCREW, CLOSURE	50	1
-	W10124350	NOT REQUIRED PART OR SEE NOTE Note: SCREW-NOT REQUIRED PART	53	0
2	12571301B	CLOSURE, DOOR (BLK)	50	1
3	12395501B	BUSHING, DOOR (BLK)	50	1
4	12636401B	STOP, DOOR (BLK)	50	1
-	M0211018	SCREW, SM Note: SCREW, DOOR STOP	50	2
5	M0311607	PLUG, BUTTON (GRY)	50	2
6	A3080001	PLUG, BUTTON (BLK)	50	1
7	67003967	GASKET, FRZ. DOOR (BLK)	50	1
8	12556901	BUCKET, UPR FZ DR	50	1
9	12557501	BUCKET, LWR FZ DR	50	3

*Color Code (-)=Not Shown #=Series, Serial Prefix or Run No., N=Not Available

Section: HANDLES (MSD2651HES-SERIES 50)

Model: MSD2651HES

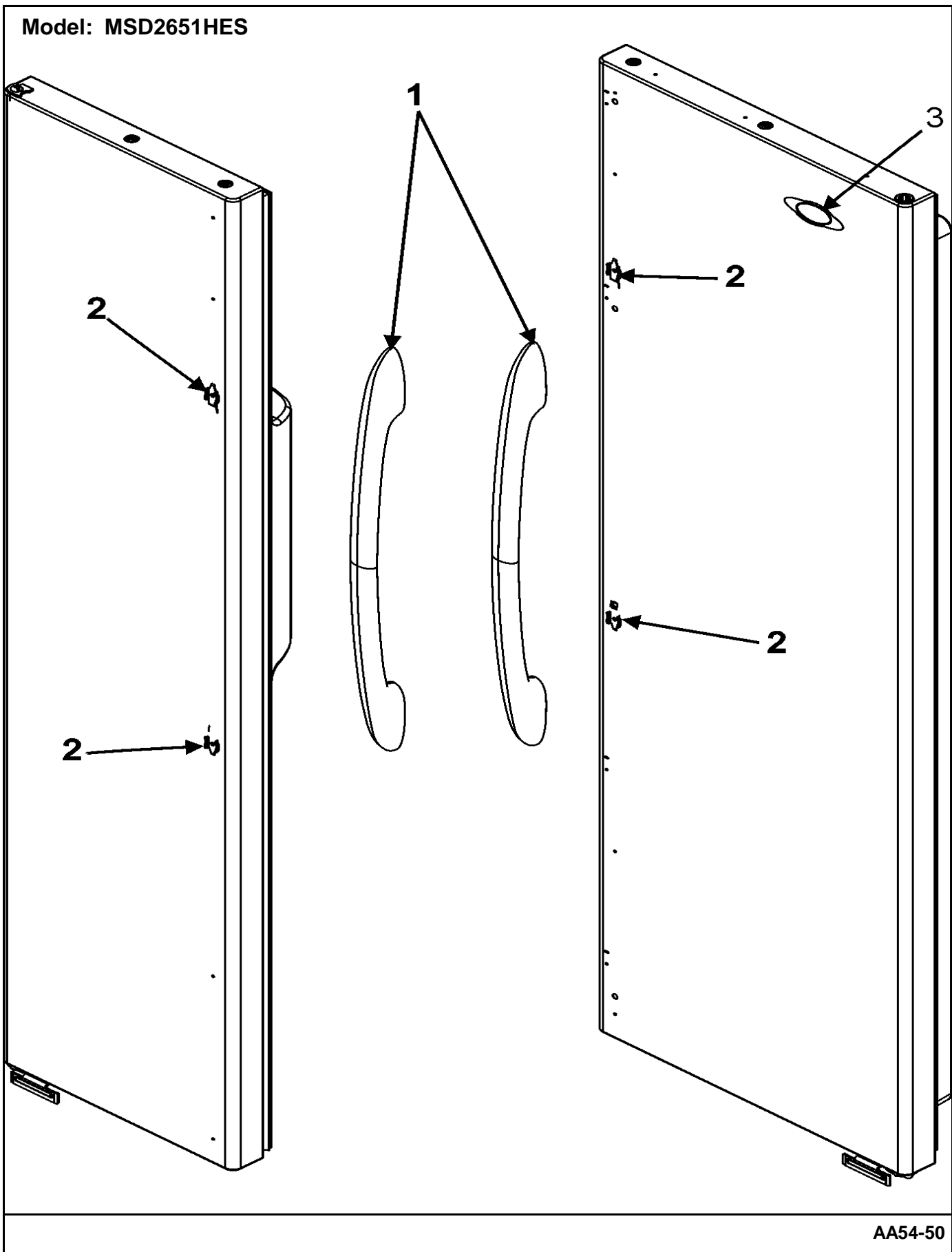

AA54-50

Section: HANDLES (MSD2651HES-SERIES 50)

No.	Part No.	Description	Series	Qty
-	67004112	CARD, HANDLE RELEASE SS & WS Note: CARD, HANDLE RELEASE	50	1
1	67004056	HANDLE ASSY., DOOR (STNLS)	50	2
-	67003800	SCREW, SM #10 Note: SCREW, CLIP	50	4
2	67003337	CLIP, HANDLE BUTTERFLY Note: CLIP, HANDLE	50	4
3	67003877	NAMEPLATE	50	1

*Color Code (-)=Not Shown #=Series, Serial Prefix or Run No., N=Not Available

Section: FOUNTAIN (SERIES 50)

Model: MSD2651HES

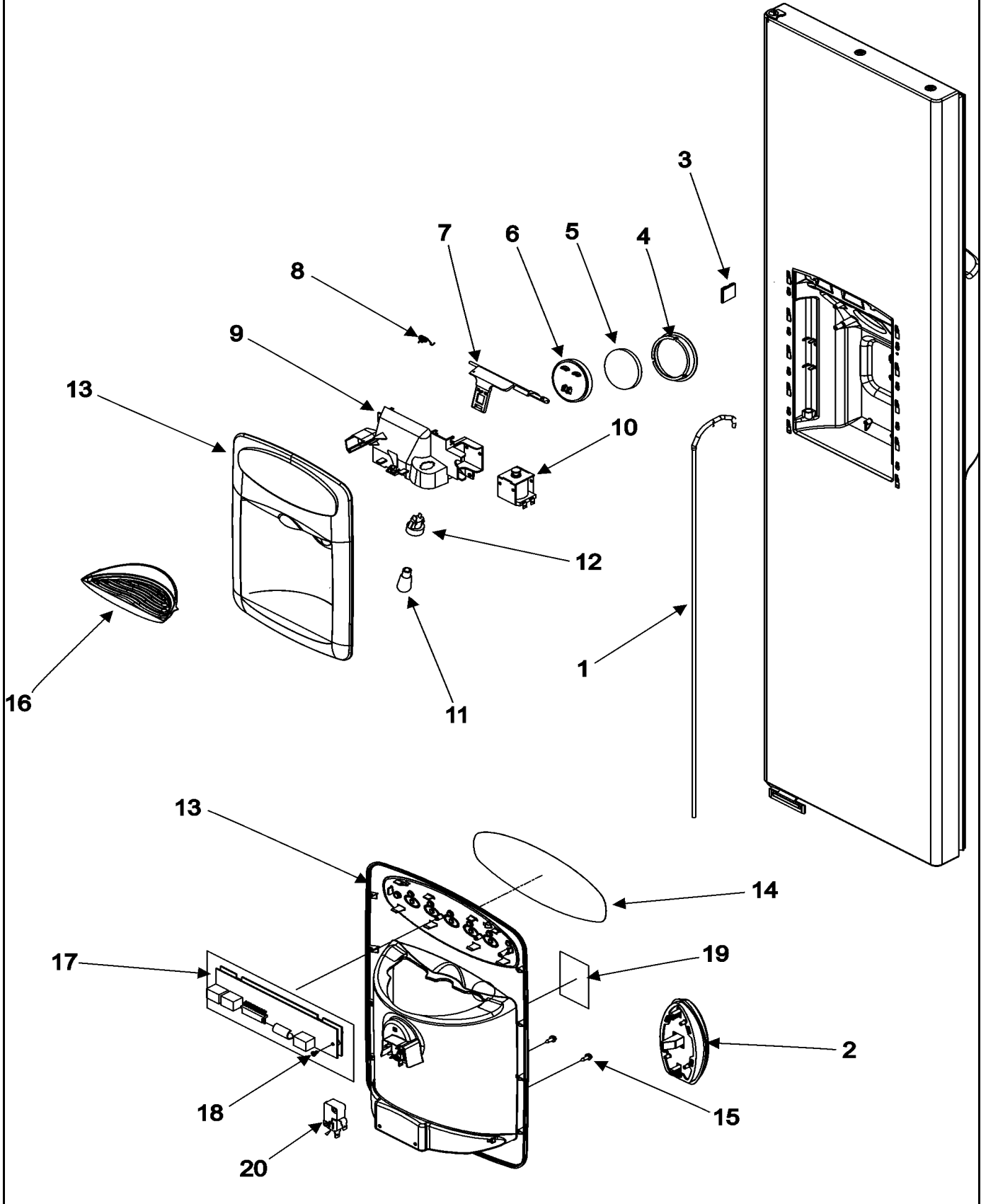

Section: FOUNTAIN (SERIES 50)

No.	Part No.	Description	Series	Qty
1	67004118	WATERLINE ASSY.	50	1
-	M0108105	CLAMP, TUBE	50	3
2	12598902B	ACTR PAD FRAME ASSY. (BLK)	50	1
3	M0104102	CLIP, CORD	50	3
4	12665101	SEAL, ICE CHUTE	50	1
5	12563401	INSUL, CHUTE DOOR**	50	1
6	12562701	DOOR, ICE CHUTE	50	1
7	67004119	HINGE, ICE CHUTE	50	1
8	12565502	SPRING, CHUTE DR	50	1
-	M0238642	SCREW, SM Note: SCREW, EXTENSION	50	1
9	67004120	EXTENSION, ICE CHUTE	50	1
-	M0200314	SCREW, MACH Note: SCREW, SOLENOID	50	1
10	12575401	SOLENOID	50	1
11	67001316	BULB, LIGHT	50	1
12	12617501	SOCKET, LIGHT	50	1
13	67004284	FACADE, 5 BUTTON (BLK)	50	1
14	67004151	INSERT, FACADE (BLK)	50	1
15	M0223230	SCREW, MOUNTING Note: SCREW, FACADE	50	2
16	Y67003722	TRAY, SUMP (BLK)	50	1
17	67003817	BOARD, CONTROL	50	1
18	M0237902	SCREW, HI/LO Note: SCREW, BOARD	50	1
19	67003351	LABEL, DISPENSER	50	1
20	12575501	SWITCH, LIMIT	50	1

*Color Code (-)=Not Shown #=Series, Serial Prefix or Run No., N=Not Available

Section: HINGES & TOE GRILLE (SERIES 50)

Model: MSD2651HES

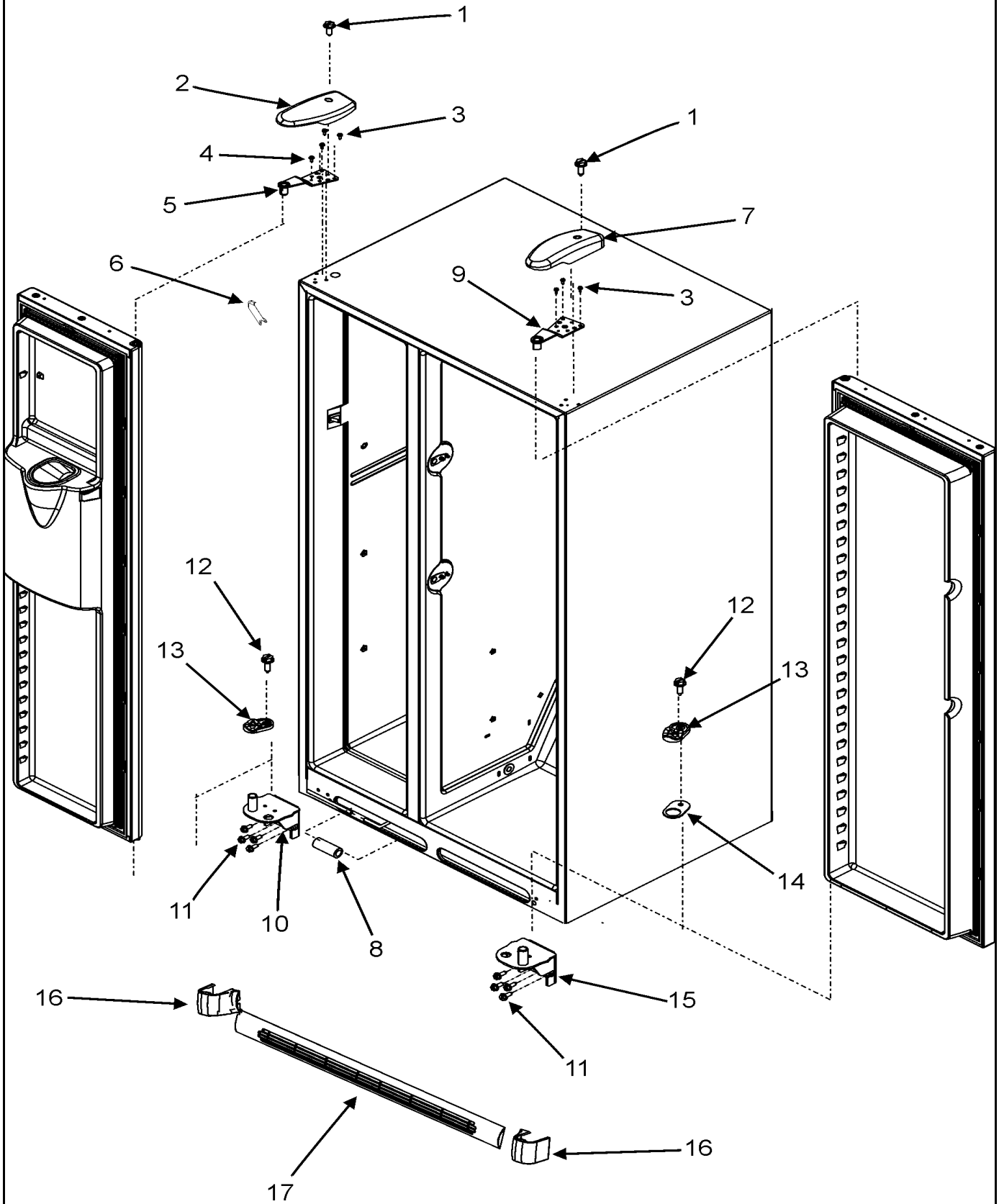

AA54-27

Section: HINGES & TOE GRILLE (SERIES 50)

No.	Part No.	Description	Series	Qty
1	M0202327	SCREW-MACH Note: SCREW, HINGE COVER	50	2
2	67003912	COVER, TOP HINGE (LT-BLK)	50	1
3	M0238731	SCREW, TF Note: SCREW, TOP HINGE	50	6
4	M0202321	SCREW, MACH	50	1
5	67004126	HINGE, TOP (LT-BLK)	50	1
6	67003485	COVER, CORNER (BLK)	50	2
7	67003913	COVER, TOP HINGE (RT-BLK)	50	1
8	61006182	UNION, TUBE (5/16"-5/16")	50	1
9	67004083	HINGE, TOP (RT-BLK)	50	1
10	12636901ED	HINGE, BOTTOM (LT-BLK)	50	1
11	67003858	SCREW, BOTTOM HINGE Note: SCREW, BOTTOM HINGE	50	8
12	M0220431	SCREW, TC Note: SCREW, DOOR CLOSURE	50	2
13	12431302	CLOSURE, DOOR (BLK)	50	2
14	10361806	SHIM, DR CLOSURE (BLK)	50	1
15	12636902ED	HINGE, BOTTOM (RT-BLK)	50	1
16	12630301B	COVER, LWR HINGE (BLK)	50	2
17	67002224	GRILLE ASSY., TOE (BLK) Note: (INCL. CLIPS)	50	1
-	12627302	CLIP, TOE GRILLE	50	2

*Color Code (-)=Not Shown #=Series, Serial Prefix or Run No., N=Not Available

Section: CONTROLS (SERIES 50)

Model: MSD2651HES

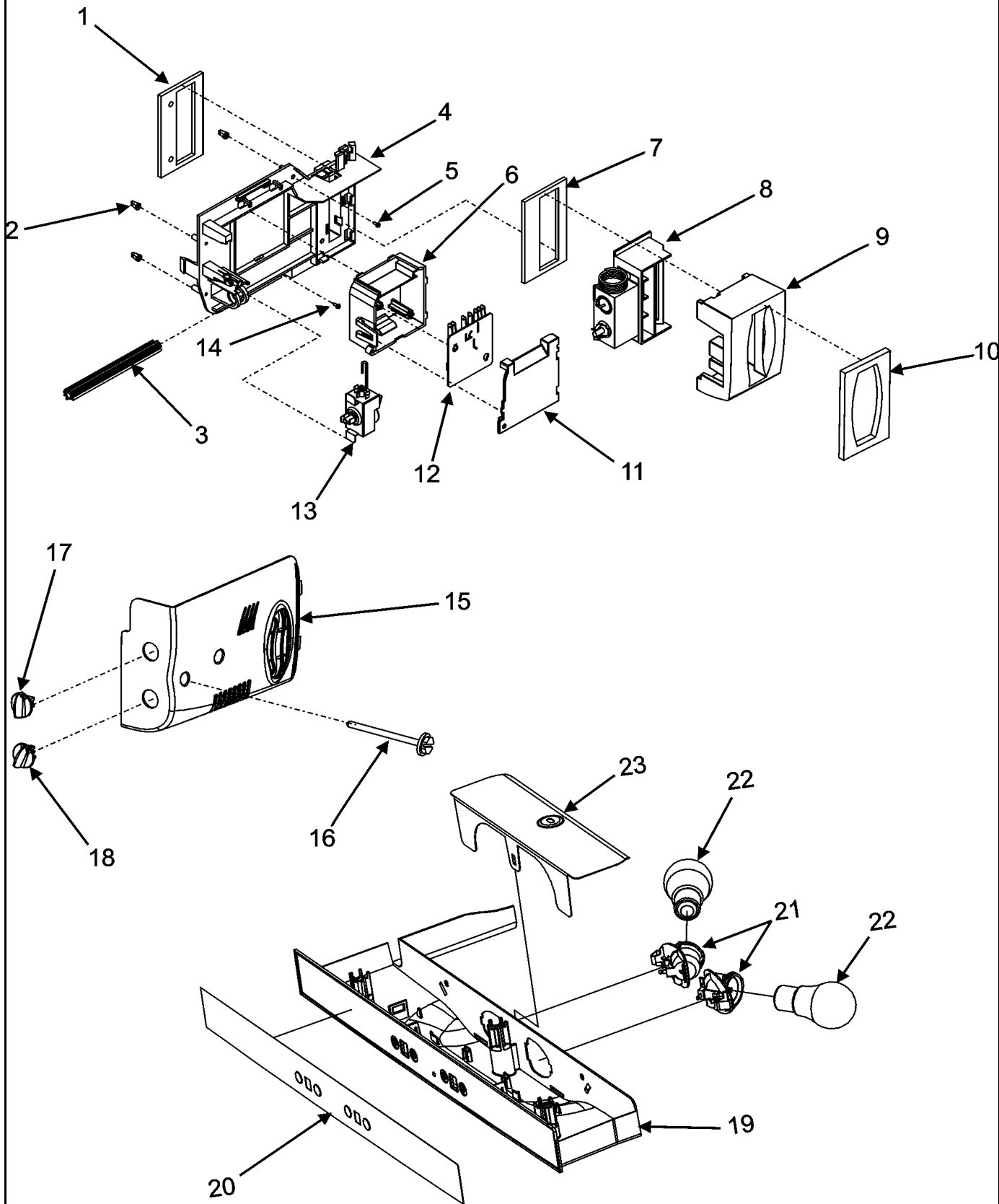

AA50-23

Section: CONTROLS (SERIES 50)

No.	Part No.	Description	Series	Qty
1	67004031	GASKET, DAMPER	50	1
2	M0580205	GROMMET, SCREW	50	3
3	N 12571801	EXTENSION, KNOB	50	1
4	67002981	BRACKET, CONTROL	50	1
5	N M0216539	SCREW Note: SCREW, BRACKET	50	1
6	12624801	BOX, DEFROST CONTROL	50	1
7	12582801	GASKET, DAMPER	50	1
8	12571701	CONTROL, DAMPER	50	1
9	12604201	INSULATION, DAMPER	50	1
10	12582901	GASKET, CONTROL COVER	50	1
11	12624901	COVER, DEFROST CONTROL	50	1
12	67003375	BOARD, ADAPTIVE DEFROST	50	1
13	67003815	CONTROL, FZ TEMP	50	1
14	M0211018	SCREW, SM Note: SCREW	50	1
15	67004158	COVER, CONTROL	50	1
16	M0231426	SCREW Note: SCREW, CONTROL COVER	50	1
17	12581101	KNOB, CONTROL	50	1
18	12581102	KNOB, CONTROL	50	1
-	M0238636	SCREW-SM Note: SCREW, HOUSING	50	3
19	67004240	HOUSING, FZ CONTROL	50	1
20	67004241	OVERLAY	50	1
21	12570701	SOCKET, LIGHT	50	2
22	67003568	BULB, LIGHT (40 WATT)	50	2
23	67004157	REFLECTOR, LIGHT	50	1
-	67004154	HARNESS, CONTROL	50	1

*Color Code (-)=Not Shown #=Series, Serial Prefix or Run No., N=Not Available

Section: REFRIGERATOR SHELVES (SERIES 50)

Model: MSD2651HES

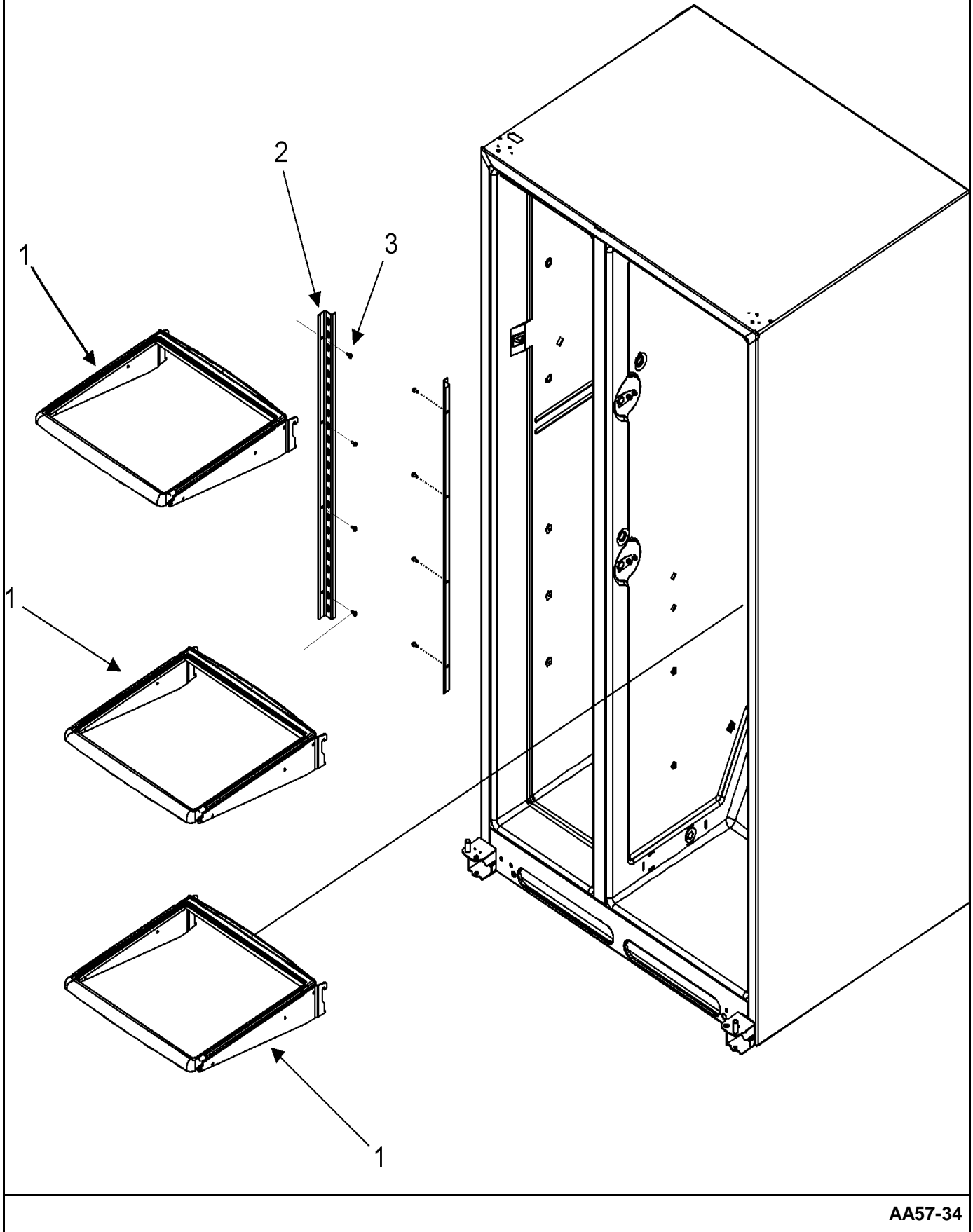

AA57-34

Section: REFRIGERATOR SHELVES (SERIES 50)

No.	Part No.	Description	Series	Qty
1	67004348	SHELF, STATIONARY	50	3
2	67003839	RAIL, L/R SM SXS	50	2
3	M0211016	SCREW, SM Note: SCREW, LADDER	50	6

*Color Code (-)=Not Shown #=Series, Serial Prefix or Run No., N=Not Available

Section: CRISPER ASSEMBLY (SERIES 50)

Model: MSD2651HES

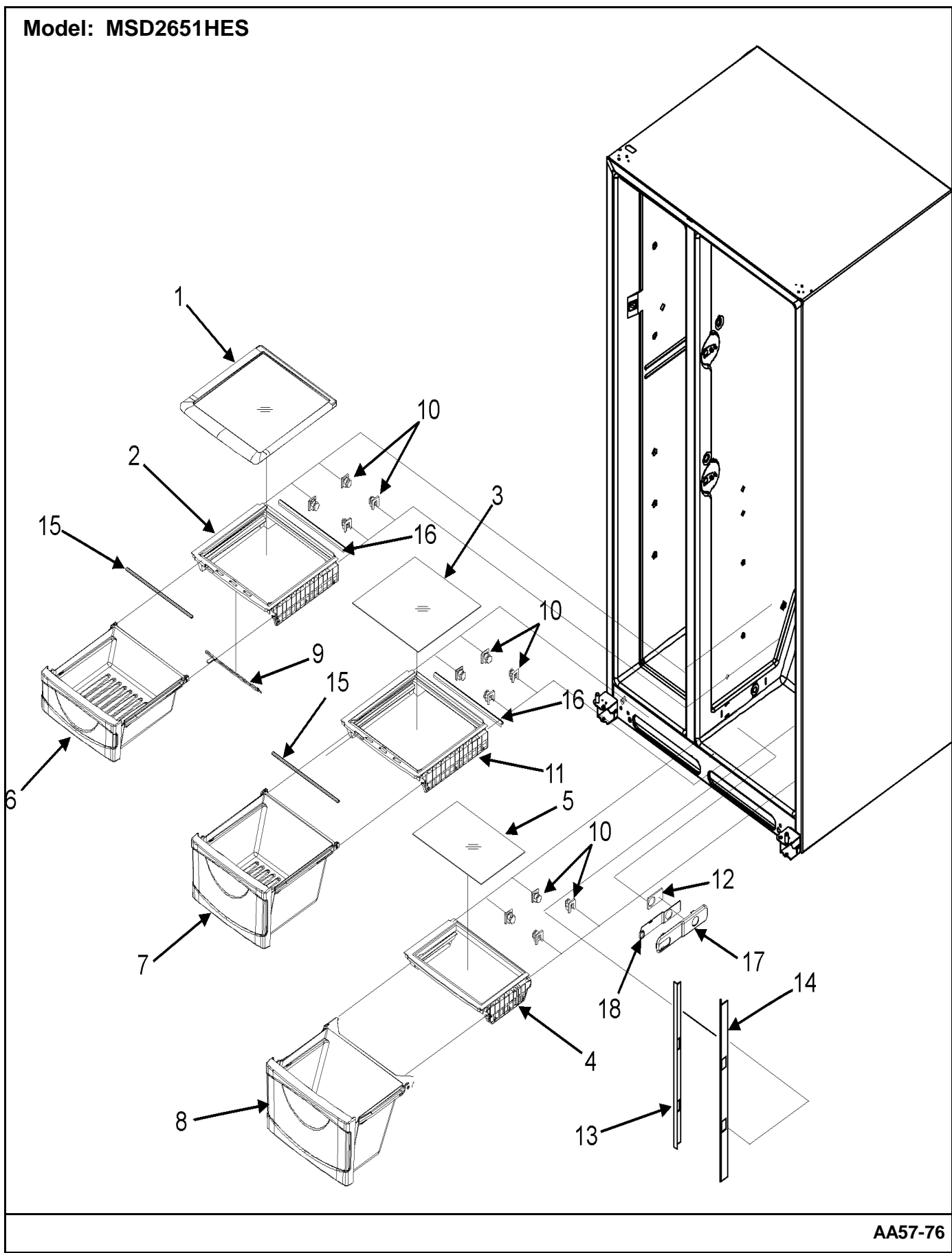

AA57-76

Section: CRISPER ASSEMBLY (SERIES 50)

No.	Part No.	Description	Series	Qty
1	67004130	SHELF, CRISPER TOP	50	1
2	67004352	FRAME, LG CRISPER SHELF Note: FRAME, SM CRISPER SHELF	50	1
3	67004246	GLASS, CRISPER SHELF	50	1
4	67004247	FRAME, MEAT SHELF	50	1
5	67004132	GLASS, MEAT SHELF	50	1
6	67004349	PAN ASSY., SM CRISPER	50	1
7	67004350	PAN ASSY., LG CRISPER	50	1
8	67004351	PAN ASSY., MEAT	50	1
9	67004168	SLIDE, CONTROL	50	1
10	12603701	SUPPORT, CRISPER FRAME	50	12
11	67004140	FRAME, CRISPER SHELF	50	1
12	67004177	GASKET, TEMP. CONTROL	50	1
13	67004170	PILLAR (LT)	50	1
14	67004171	PILLAR (RT)	50	1
15	67004248	SEAL, CRISPER FRAME (FRT)	50	2
16	67004249	SEAL, CRISPER FRAME (REAR)	50	2
17	67004175	HOUSING, TEMP. CONTROL	50	1
18	67004176	SLIDE, TEMP. CONTROL	50	1

*Color Code (-)=Not Shown #=Series, Serial Prefix or Run No., N=Not Available

Section: FREEZER SHELVES (SERIES 50)

Model: MSD2651HES

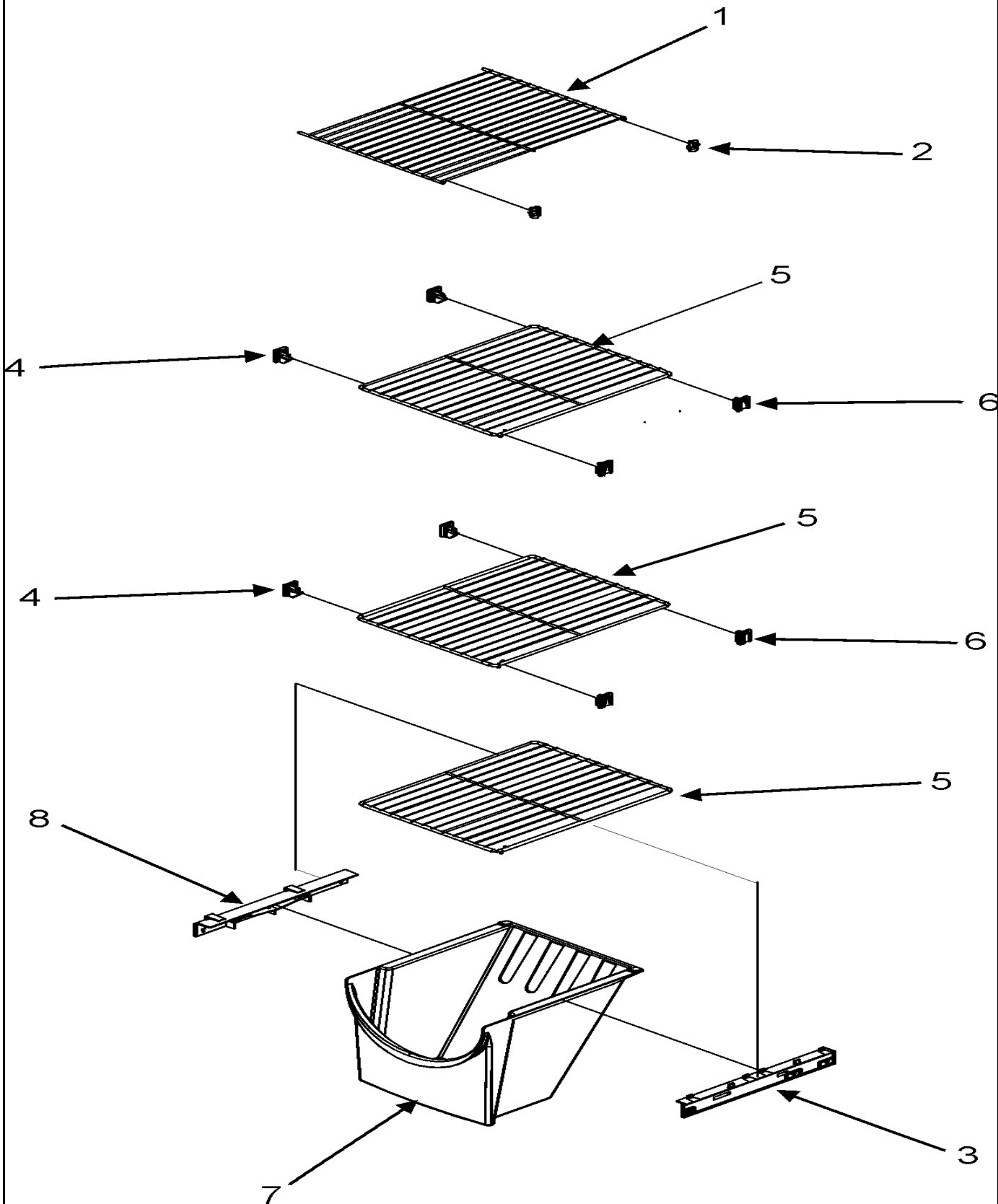

AA53-16

Section: FREEZER SHELVES (SERIES 50)

No.	Part No.	Description	Series	Qty
1	67004354	SHELF, UPR FRZ.	50	1
2	C8973801	SUPPORT, FRZ SHELF	50	2
3	67004356	RAIL, BIN (RT)	50	1
4	12015002	SUPPORT, SHELF (LT)	50	4
5	67004250	SHELF, LWR FZ	50	3
6	10941102	SUPPORT, SHELF (RT)	50	4
7	12596501	BIN, FZ	50	1
8	67004355	RAIL, BIN (LT)	50	1

*Color Code (-)=Not Shown #=Series, Serial Prefix or Run No., N=Not Available

Section: EVAP FAN/CRISP LIGHT/FILTER (SER.50)

Model: MSD2651HES

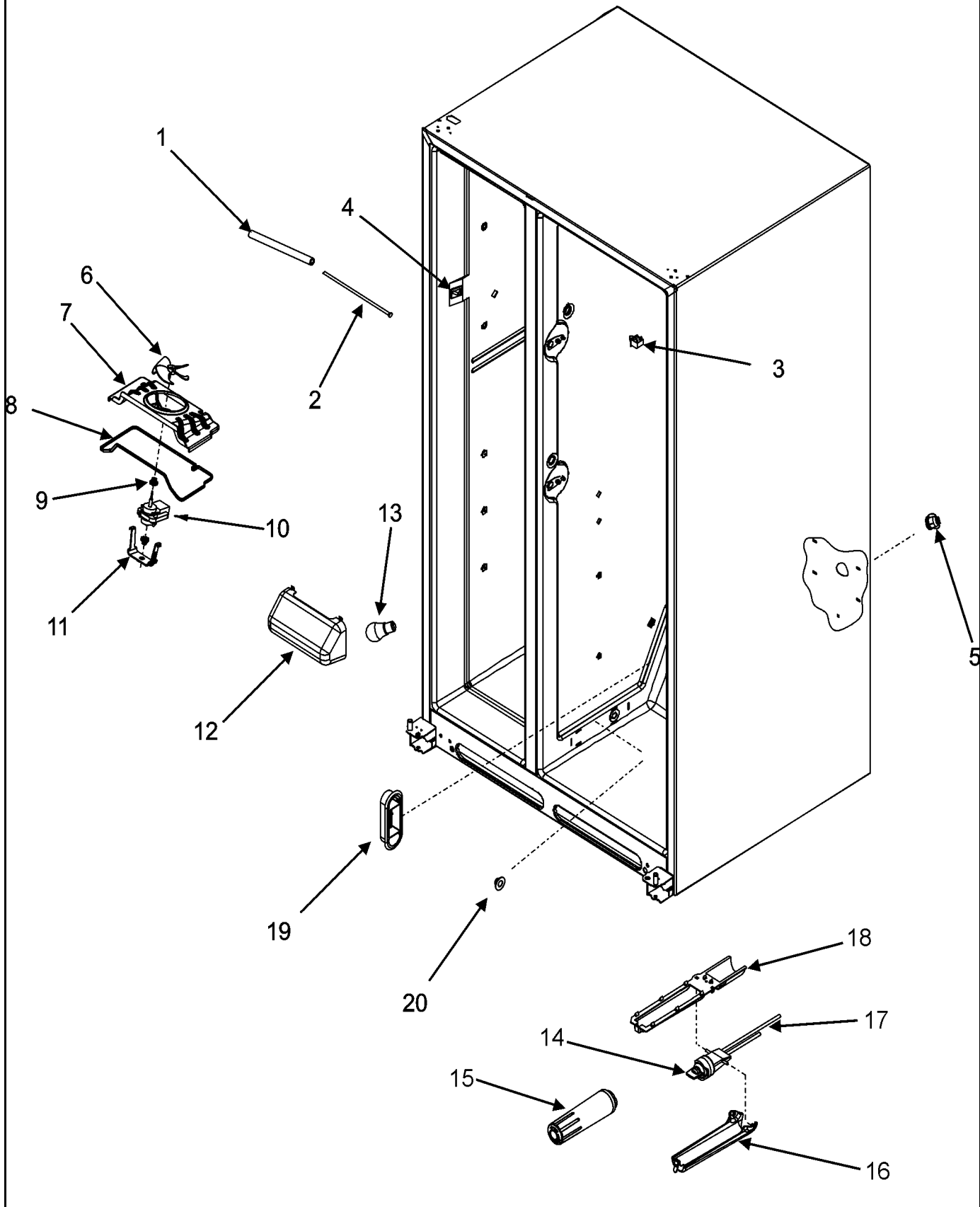

AA53-11

Section: EVAP FAN/CRISP LIGHT/FILTER (SER.50)

No.	Part No.	Description	Series	Qty
1	67004185	INSULATION, TUBING	50	1
2	67004186	TUBE, PLASTIC	50	1
3	12466104	SWITCH, REF LIGHT	50	1
4	12466103	SWITCH, LIGHT	50	1
5	12570701	SOCKET, LIGHT	50	1
6	12217201	FAN, EVAPORATOR	50	1
7	67004253	SHROUD, EVAP	50	1
8	67001508	GASKET Note: GASKET, SHROUD	50	1
9	67002780	GROMMET, FAN MOTOR (BLK)	50	2
10	67003636	MOTOR, EVAP FAN	50	1
11	67003083	CLIP Note: CLIP, EVAP MOTOR	50	1
12	67001507	SHIELD, CRISPER LIGHT	50	1
13	67003568	BULB, LIGHT (40 WATT)	50	1
14	67003146	PLUG, BYPASS Note: PLUG, BYPASS	50	1
15	67003591	FILTER, WATER SINGLE Note: FILTER, WATER	50	1
16	12568001	COVER, FILTER	50	1
17	67004106	HEAD, WATER FILTER (W/TUBING)	50	1
18	12688503	PLATE, FILTER BACKING	50	1
19	12634801	GRILLE, RETURN AIR	50	1
20	67003018	PLUG, AIR TUNNEL	50	1

*Color Code (-)=Not Shown #=Series, Serial Prefix or Run No., N=Not Available

Section: EVAPORATOR/ROLLERS/WATER TANK (SER.50)

Model: MSD2651HES

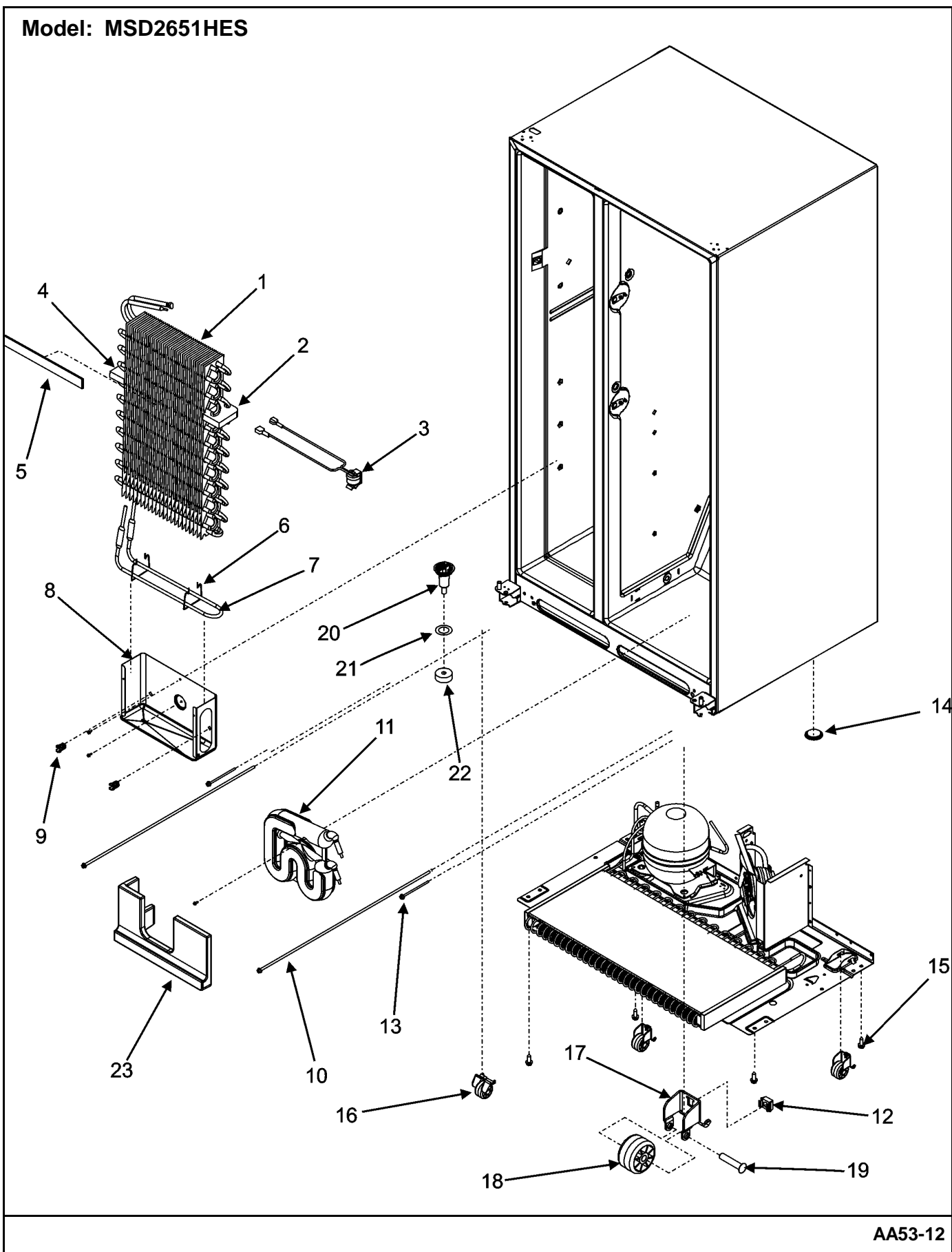

AA53-12

Section: EVAPORATOR/ROLLERS/WATER TANK (SE

No.	Part No.	Description	Series	Qty
1	12001940	EVAP KIT (SXS)--W	50	1
2	12590102	BLOCK, AIR COIL (RT)	50	1
3	67003964	THERMOSTAT, DEFROST	50	1
4	12590101	BLOCK, AIR COIL (LT)	50	1
5	67002226	GASKET, FOAM	50	1
6	10428101	CLIP, EVAP HEATER	50	2
7	67004188	HEATER, EVAP	50	1
8	12558101WD	TRAY, EVAP DRIP	50	1
-	M0224416	SCREW, SM Note: SCREW, TRAY	50	2
9	10623003	CLIP, EVAPORATOR	50	2
10	10093313	SCREW, ADJUSTING	50	2
-	M0211018	SCREW, SM Note: SCREW, TANK	50	1
11	67003504	TANK, WATER	50	1
12	M0286708	NUT, SPEED	50	4
13	12606102	BOLT, ROLLER ADJ	50	2
14	A3076901	PLUG, BUTTON	50	1
15	67001510	SCREW	50	4
16	67002227	ROLLER BRACKET ASSY	50	4
17	12456801	BRACKET, ROLLER	50	4
18	10450602	ROLLER	50	4
19	M1205302	RIVET	50	4
20	12456901	FUNNEL, DRAIN	50	1
21	M0500703	SEAL, O RING	50	1
22	B8381501	GASKET, DRAIN TUBE	50	1
23	67004309	BLOCK, WATER TANK	50	1
-	67004189	HEATER/HARNESS, FRZ	50	1

*Color Code (-)=Not Shown #=Series, Serial Prefix or Run No., N=Not Available

Section: FREEZER COMPARTMENT (SERIES 50)

Model: MSD2651HES

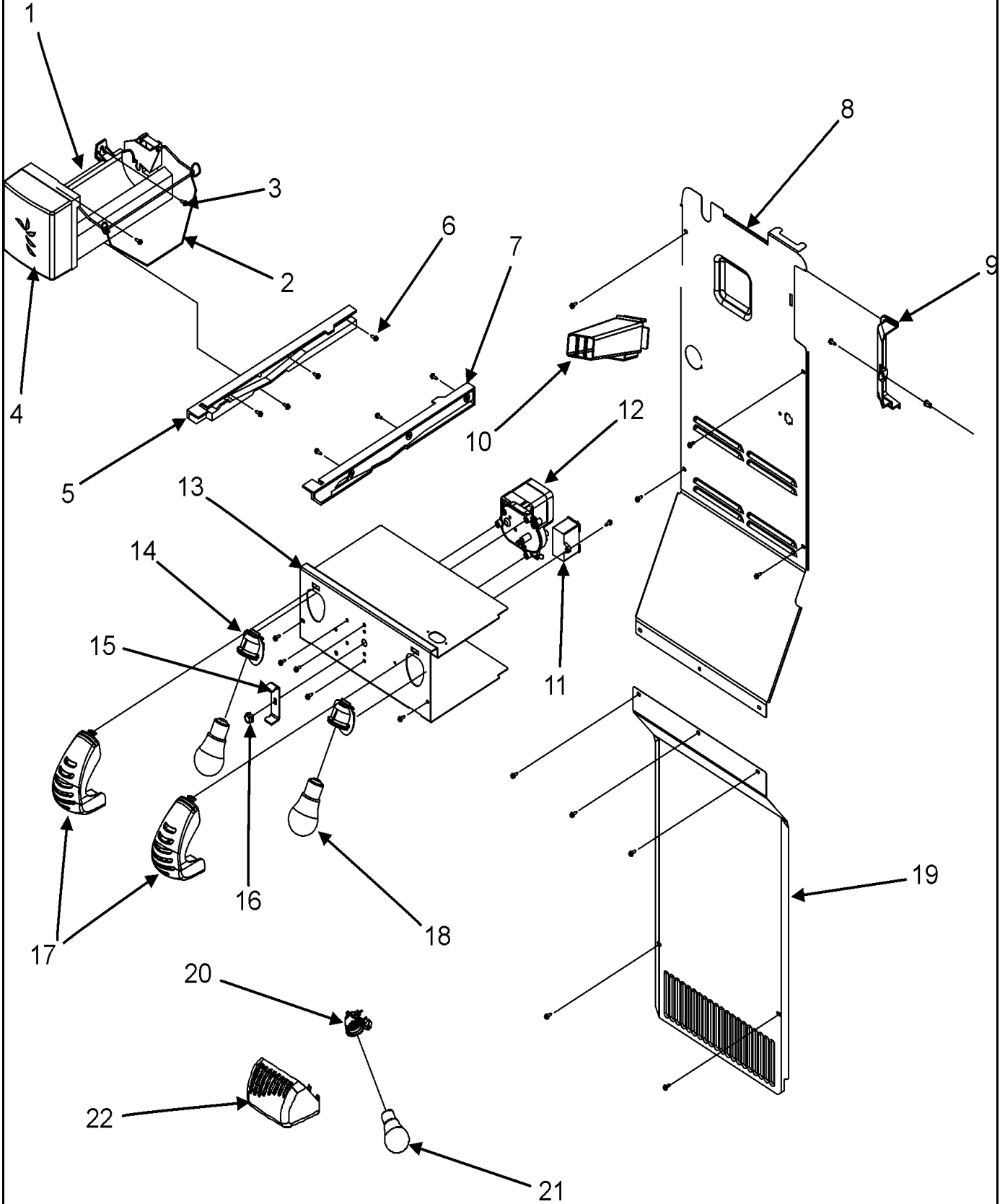

AA53-10

Section: FREEZER COMPARTMENT (SERIES 50)

No.	Part No.	Description	Series	Qty
-	67002823	BRKT, ICE MAKER	50	1
1	61005508	ICE MAKER ASSY.	50	1
2	12671401	ASSY, IM ARM/WIRE	50	1
3	M0238833	SCREW SHOULDER Note: SCREW, ICE MAKER	50	2
4	12582501	COVER, ICE MAKER	50	1
5	67004322	GLIDE, FRZ. (LT)	50	1
6	M0213530	SCREW, SM (STNLS) Note: SCREW, GLIDE (STNLS)	50	7
7	67004323	GLIDE, FRZ. (RT)	50	1
-	M0238616	SCREW, SM Note: SCREW, BACK	50	4
8	67003577	BACK INNER FZ 26 Note: BACK, INNER FZ	50	1
-	M0238616	SCREW, SM Note: SCREW, COVER	50	1
-	M0580205	GROMMET, SCREW	50	1
9	12583101	COVER, SUPPLY AIR	50	1
10	67003578	DUCT, QUICK ICE 26	50	1
11	C8931612	CAPACITOR	50	1
-	M0226528	SCREW, TC Note: SCREW, CAPACITOR	50	1
-	M0226528	SCREW, TC Note: SCREW, MOTOR	50	3
12	67003226	MOTOR, AUGER	50	1
-	M0238616	SCREW, SM Note: SCREW, COVER	50	2
13	12561701	COVER, AUGER MOTOR	50	1
14	12570701	SOCKET, LIGHT	50	2
15	10114901	DRIVER (ICE MAKER)	50	1
16	M0223101	NUT, LOCKING	50	1
17	67004433	SHIELD, FZ LIGHT	50	2
18	67003568	BULB, LIGHT (40 WATT)	50	2
-	M0238616	SCREW, SM Note: SCREW, COVER	50	5
19	67004192	COVER, EVAP	50	1
20	12570701	SOCKET, LIGHT	50	1
21	67003568	BULB, LIGHT (40 WATT)	50	1
22	67004135	SHIELD, FZ LIGHT	50	1

*Color Code (-)=Not Shown #=Series, Serial Prefix or Run No., N=Not Available

Section: COMPRESSOR (SERIES 50)

Model: MSD2651HES

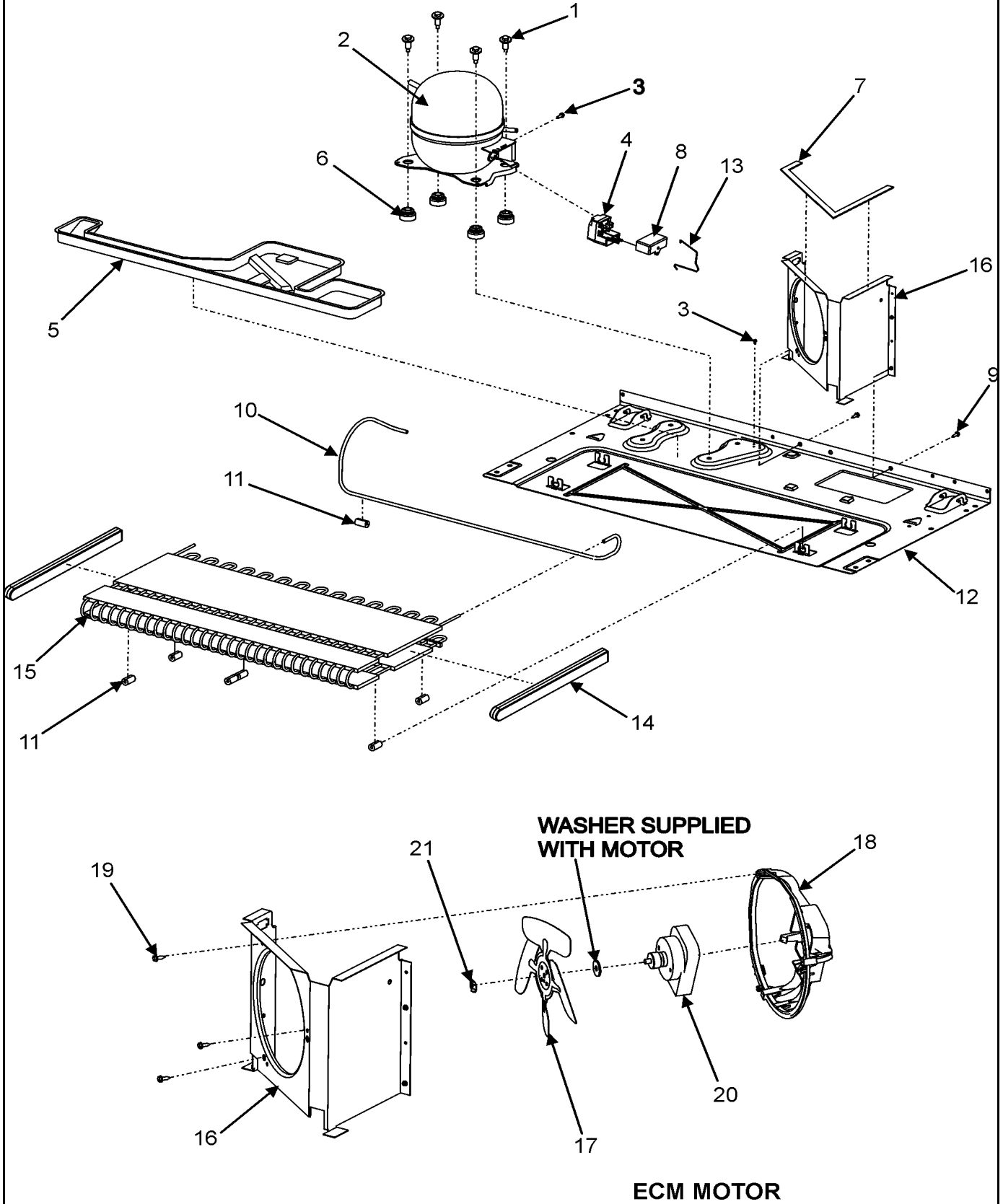

AA51-13

Section: COMPRESSOR (SERIES 50)

No.	Part No.	Description	Series	Qty
1	N M0221523	SCREW, SHLDR Note: SCREW, COMPRESSOR	50	3
2	67002782	COMPRESSOR, TPG1380YXA (SXS)	50	1
3	M0231604	SCREW, TF Note: SCREW	50	2
4	67003764	OVERLOAD/RELAY W/CAPACITOR	50	1
5	67004848	PAN, DRAIN	50	1
6	67003493	GROMMET, COMPRESSOR	50	4
7	61003210	SEAL	50	1
8	C8931612	CAPACITOR	50	1
9	M0238616	SCREW, SM Note: SCREW	50	3
10	67004700	TUBE, DISCHARGE	50	1
11	12578601	GROMMET, CONDENSER	50	8
12	67001512	PAN, BASE	50	1
13	12576801	STRAP, BALE	50	1
14	67002235	BLOCK-EPS COND	50	2
15	67004682	CONDENSER *	50	1
16	67001090	SHROUD, CONDENSER FAN	50	1
17	12587601	BLADE, COND FAN	50	1
18	67003644	BRKT, ECM COND MOTOR	50	1
19	M0223816	SCREW, TR Note: SCREW, BRACKET	50	3
20	12628701	MOTOR, CONDENSER FAN (ECM)	50	1
21	12632601	NUT, ECM MOTOR	50	1
-	67004097	HARNESS, MC	50	1

*Color Code (-)=Not Shown #=Series, Serial Prefix or Run No., N=Not Available

Section: CABINET BACK (SERIES 50)

Model: MSD2651HES

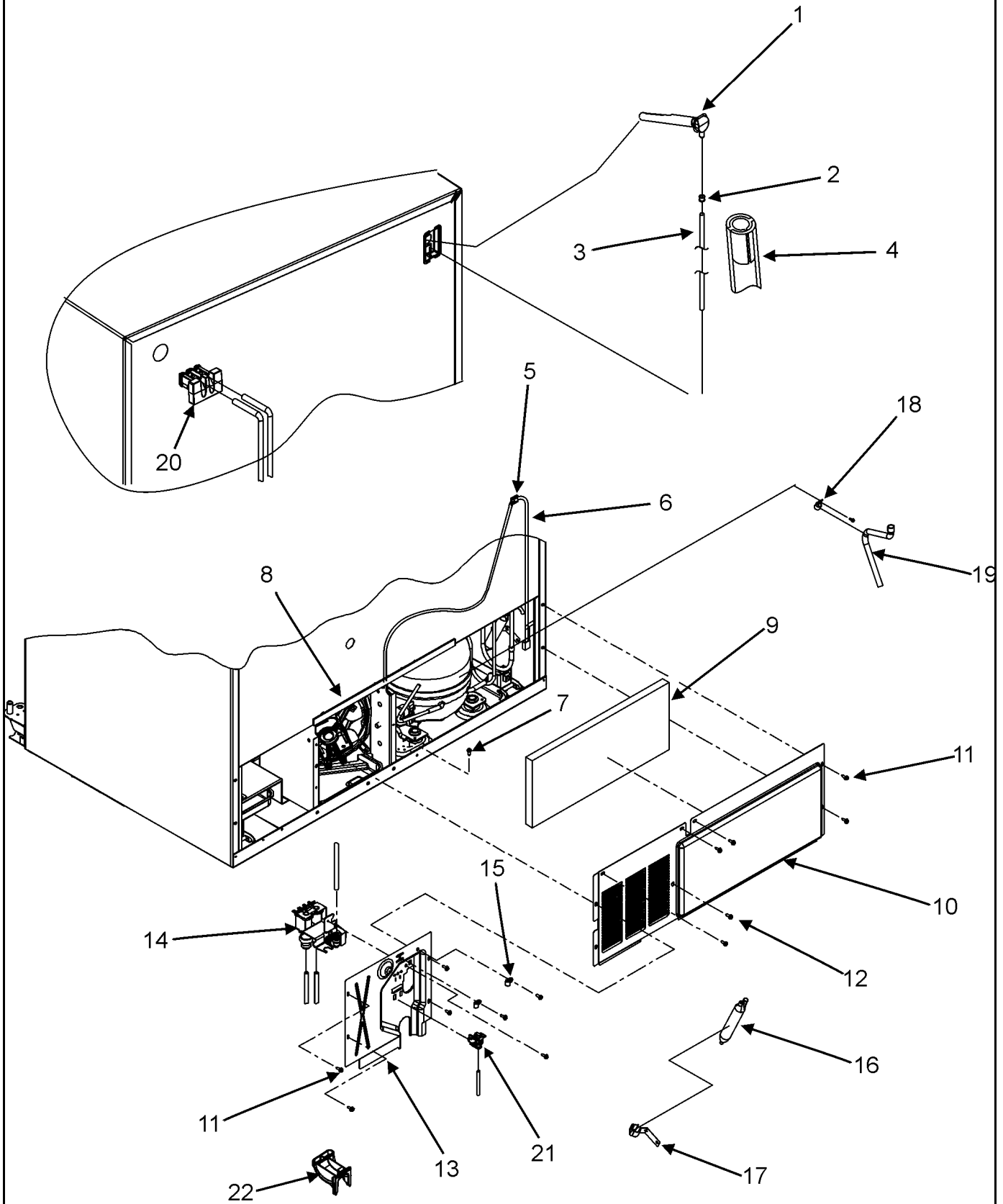

AA56-50

Section: CABINET BACK (SERIES 50)

No.	Part No.	Description	Series	Qty
1	67003576	ELBOW, FILL TUBE	50	1
2	M0114003	CLIP, SPEED	50	1
3	67003360	TUBE, PLASTIC	50	1
4	A3223101	INSERT, PLASTIC TUBE	50	1
5	M0104106	CLIP	50	1
6	12583301	CORD, POWER	50	1
7	N M0239216	SCREW, CA Note: SCREW	50	1
8	B5759649	GASKET, MC BACK	50	1
9	67003796	FIBER, ACOUSTIC	50	1
10	12575101ED	BACK, MACH COMP	50	1
11	M0238616	SCREW, SM Note: SCREW, COVER	50	11
12	M0251015	SCREW	50	1
13	67004098	COVER, WATER VALVE	50	1
14	67003818	VALVE, DUAL WATER	50	1
-	M0251015	SCREW Note: SCREW, VALVE	50	1
15	M0108105	CLAMP, TUBE	50	2
16	B2150504	DRIER	50	1
17	10547002	CLIP, DRIER	50	1
-	67002999	SCREW, SM Note: SCREW, CLIP	50	1
18	M0102303	CLAMP	50	1
-	M0220617	SCREW Note: SCREW, CLAMP	50	1
19	12580401	TUBE, DRAIN	50	1
20	67004092	BLOCK, FILTER	50	1
21	67004100	CLIP, WATERLINE	50	1
21	W10124350	NOT REQUIRED PART OR SEE NOTE Note: CLIP-NOT REQUIRED PART	53	1
22	67004101	SWEEP, DUAL TUBE	50	1
-	67004102	TRACK, WATERLINE	50	1

*Color Code (-)=Not Shown #=Series, Serial Prefix or Run No., N=Not Available

Section: ICE MAKER (SERIES 50)

Model: MSD2651HES

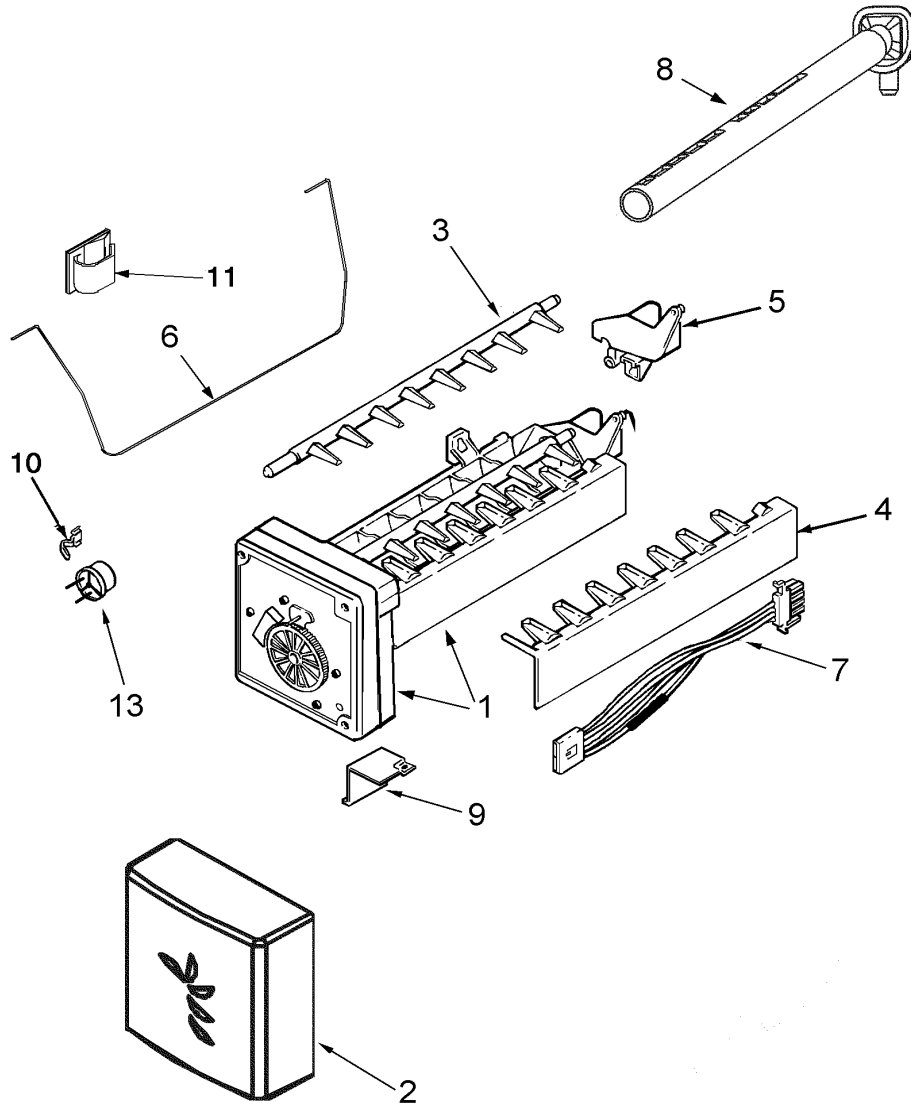

Section: ICE MAKER (SERIES 50)

No.	Part No.	Description	Series	Qty
-	67002823	BRKT, ICE MAKER	50	1
1	61005508	ICE MAKER ASSY.	50	1
-	M0238833	SCREW SHOULDER Note: SCREW, ICE MAKER	50	2
2	12582501	COVER, ICE MAKER	50	1
3	95101-1	EJECTOR, ICE	50	1
4	95102-1	STRIPPER, ICE	50	1
5	95100-1	INLET, WATER	50	1
6	12671401Q	IM ARM/WIRE ASSY	50	1
7	67002124	HARNESS, ICE MAKER	50	1
8	67003576	ELBOW, FILL TUBE	50	1
9	95107-1	BRACKET, MODULE & HEATER	50	1
-	95108-1	SCREW, BRACKET	50	1
10	95104-1	RETAINER, THERMOSTAT	50	1
11	M0104106	CLIP	50	2
12	95092-1	THERMOSTAT	50	1
- N	95093-1	CEMENT, ALUMILASTIC (4 OZ.)	50	1
-	10244904	COUPLING	50	1
-	R0131235	ICE MAKER HOOK UP KIT Note: (INCL. 1/4" X 25' COPPER TUBE, NON PIERCING SADDLE VALVE, & 1/4" COMPRESSION NUT & SLEEVE)	50	1

*Color Code (-)=Not Shown #=Series, Serial Prefix or Run No., N=Not Available

Section: ICE BUCKET ASSY. (SERIES 50)

Model: MSD2651HES

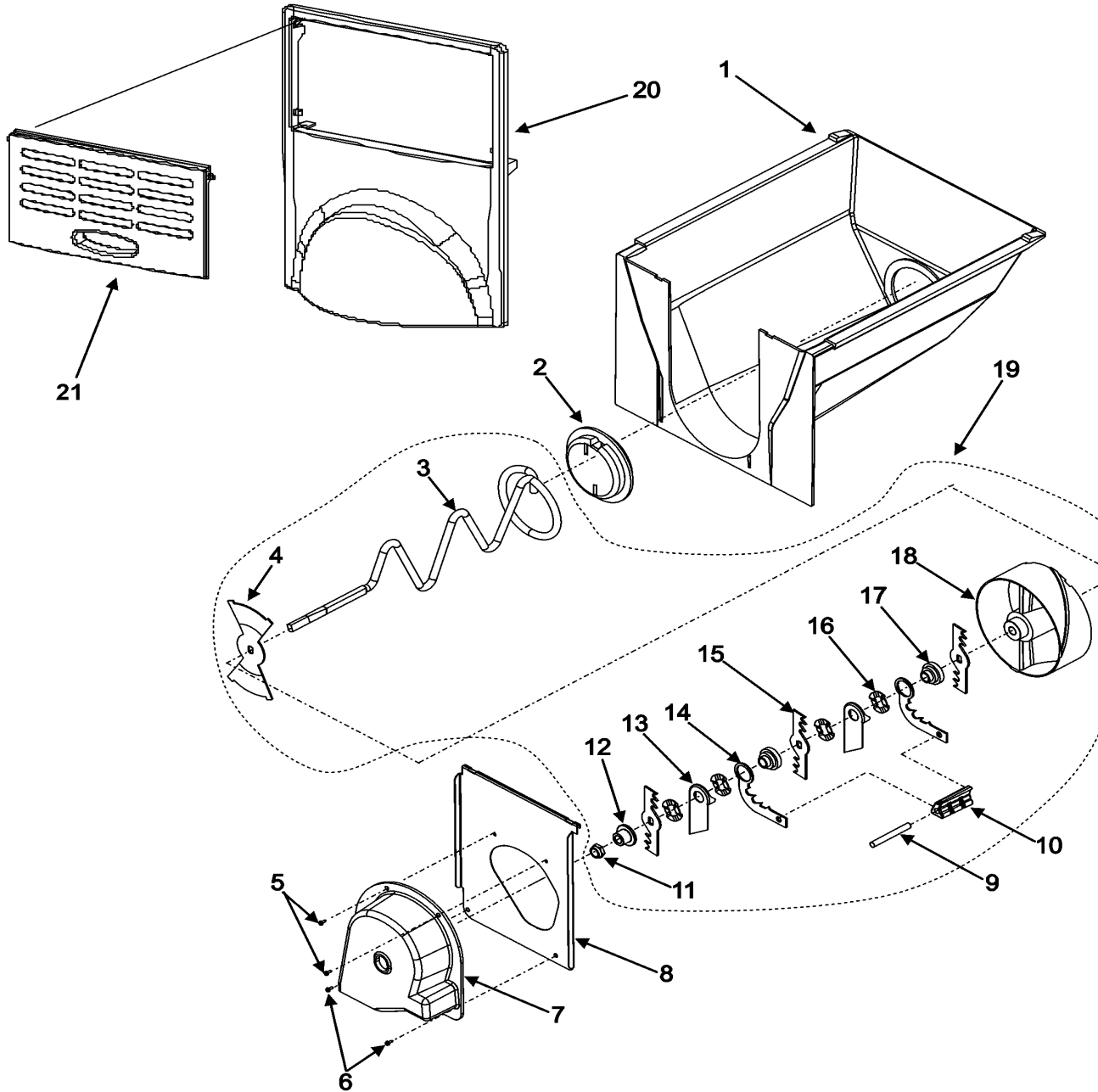

Section: ICE BUCKET ASSY. (SERIES 50)

No.	Part No.	Description	Series	Qty
1	12517801	BUCKET, ICE CRUSH	50	1
2	D7749401	CAP, HELIX END	50	1
3	10114401	AGITATOR, ICE	50	1
4	10113801	BAR, CRSH ICE BUCKET	50	1
5	59001208	SCREW, HEX HEAD	50	2
6	M0238616	SCREW, SM	50	2
7	67002271	COVER, BLADE	50	1
8	10115001	FRONT, ICE CRUSHER	50	1
9	M1200108	PIN, ROLL	50	1
10	10114101	ANCHOR, BLADE	50	1
11	M0223101	NUT, LOCKING	50	1
12	10113901	SPACER, COVER	50	1
13	10275201	DAMPER, ICE	50	2
14	10114601	BLADE, STATIC	50	2
15	10114501	BLADE, ROTATING	50	3
16	10275101	WASHER, WAVED	50	4
17	10114301	WASHER STEPPED	50	2
18	67002052	WHEEL, CRSH ICE	50	1
19	67003350	CRUSHED ICE AGITATOR ASSY	50	1
20	67004255	COVER, ICE BUCKET	50	1
21	67004256	DOOR, ICE BUCKET	50	1

*Color Code (-)=Not Shown #=Series, Serial Prefix or Run No., N=Not Available

Section: SUPPLEMENTAL INFORMATION (SERIES 50)

Model: MSD2651HES

No image available

NOIMAGE

Section: SUPPLEMENTAL INFORMATION (SERIES 50)

No.	Part No.	Description	Series	Qty
-	12842129	MANUAL, USE & CARE	52	1
-	12842103	MANUAL, USE & CARE	50	1
-	16023088	TECH SHT, SXS	50	1
-	16026204	TECH SHT, SXS	51	1
-	67004860	TAG, ENERGY	50	1
-	16022689	SVC MAN, SXS	50	1

*Color Code (-)=Not Shown #=Series, Serial Prefix or Run No., N=Not Available

Section: WIRING INFORMATION (SERIES 50)

Model: MSD2651HES

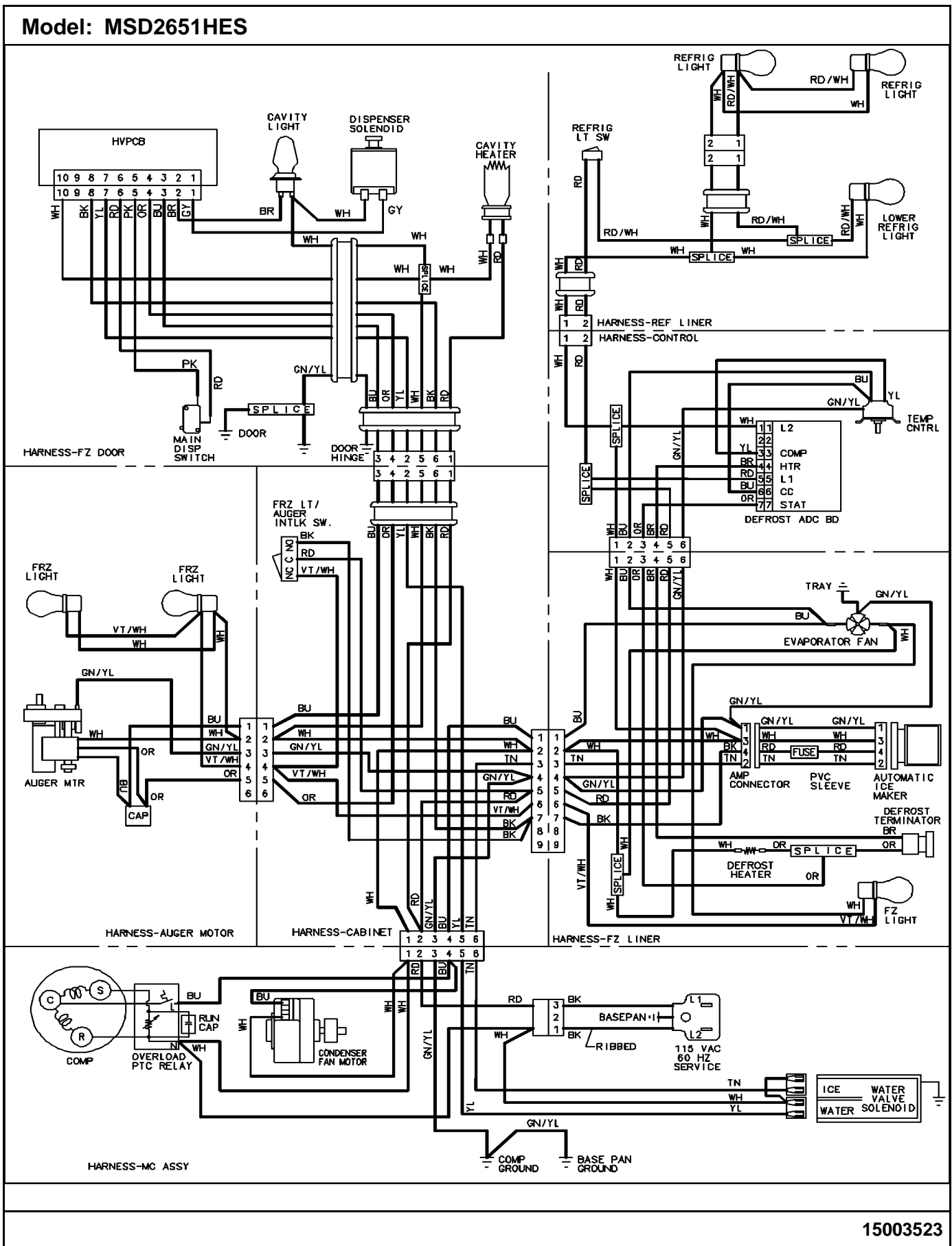

15003523

Section: WIRING INFORMATION (SERIES 50)

No.	Part No.	Description	Series Qty
-	N 15003523	WIRING INFORMATION	50 1

*Color Code (-)=Not Shown #=Series, Serial Prefix or Run No., N=Not Available

Section: COMPRESSOR (SERIES 51)

Model: MSD2651HES

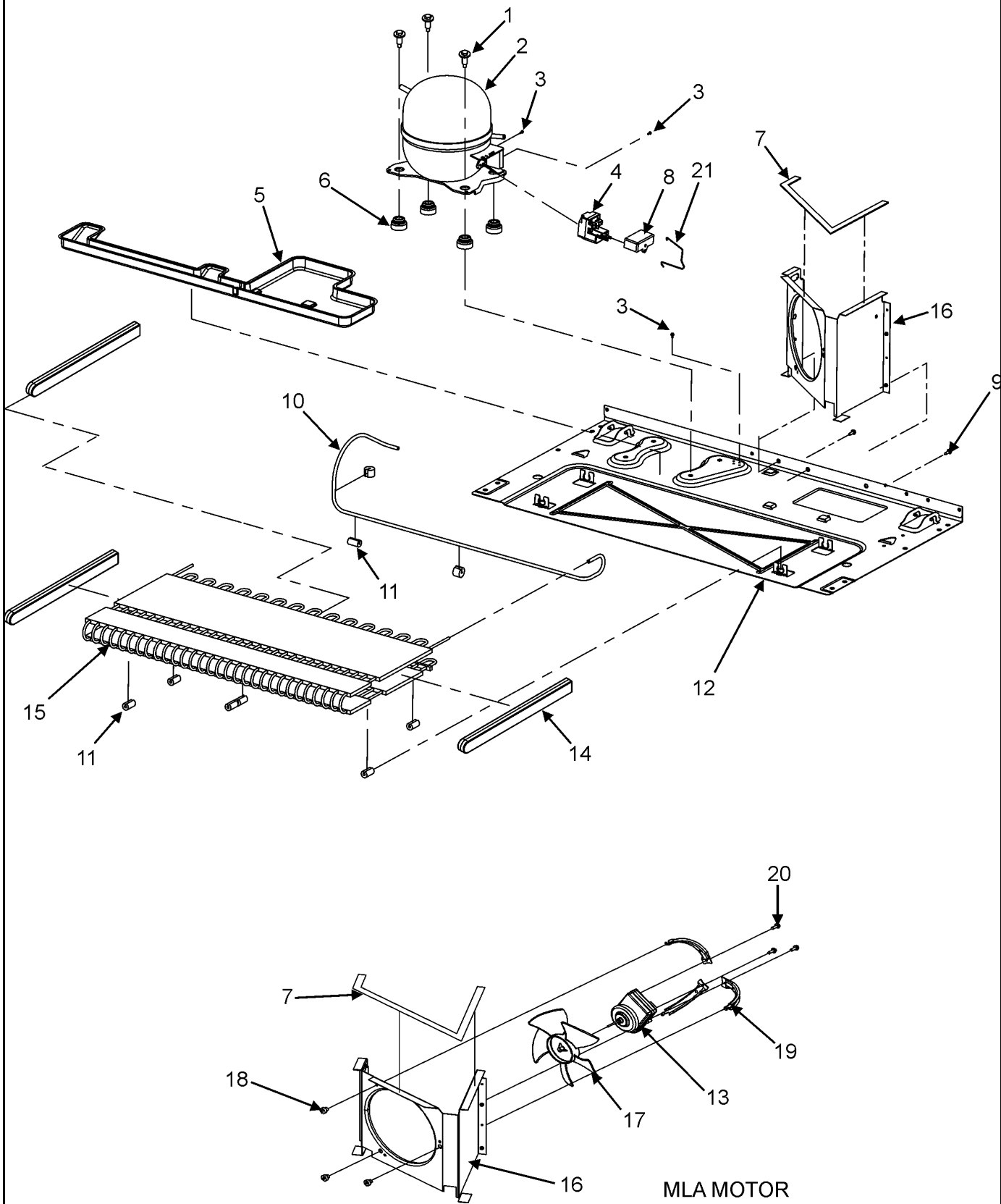

AA51-38

Section: COMPRESSOR (SERIES 51)

No.	Part No.	Description	Series	Qty
1	N M0221523	SCREW, SHLDR Note: SCREW, COMPRESSOR	51	3
2	67002782	COMPRESSOR, TPG1380YXA (SXS)	51	1
3	M0231604	SCREW, TF Note: SCREW	51	2
4	67003764	OVERLOAD/RELAY W/CAPACITOR	51	1
5	67004848	PAN, DRAIN	51	1
6	67003493	GROMMET, COMPRESSOR	51	4
7	61003210	SEAL	51	1
8	C8931612	CAPACITOR	51	1
9	M0238616	SCREW, SM Note: SCREW	51	3
10	67004700	TUBE, DISCHARGE	51	1
11	12578601	GROMMET, CONDENSER	51	8
12	67001512	PAN, BASE	51	1
13	67004432	MOTOR, CONDENSER FAN	51	1
14	67002235	BLOCK-EPS COND	51	2
15	67004682	CONDENSER *	51	1
16	67001090	SHROUD, CONDENSER FAN	51	1
17	67004952	BLADE, COND FAN	51	1
18	61004743	GROMMET, BRACKET	51	3
19	67004953	BRACKET, COND MOTOR	51	3
20	67004954	SCREW Note: SCREW, BRACKET	51	3
21	12576801	STRAP, BALE	51	1
-	67004955	HARNES, MC	51	1

*Color Code (-)=Not Shown #=Series, Serial Prefix or Run No., N=Not Available

