

REFRIGERATOR

Repair Parts List

MODEL NUMBER
MFF2557KES

When requesting service or ordering parts, always provide the following information:

- Product Type
- Part Number
- Model Number
- Part Description

MAYTAG®

©2005 Maytag Services

Section: HANDLES

Model: MFF2557KES

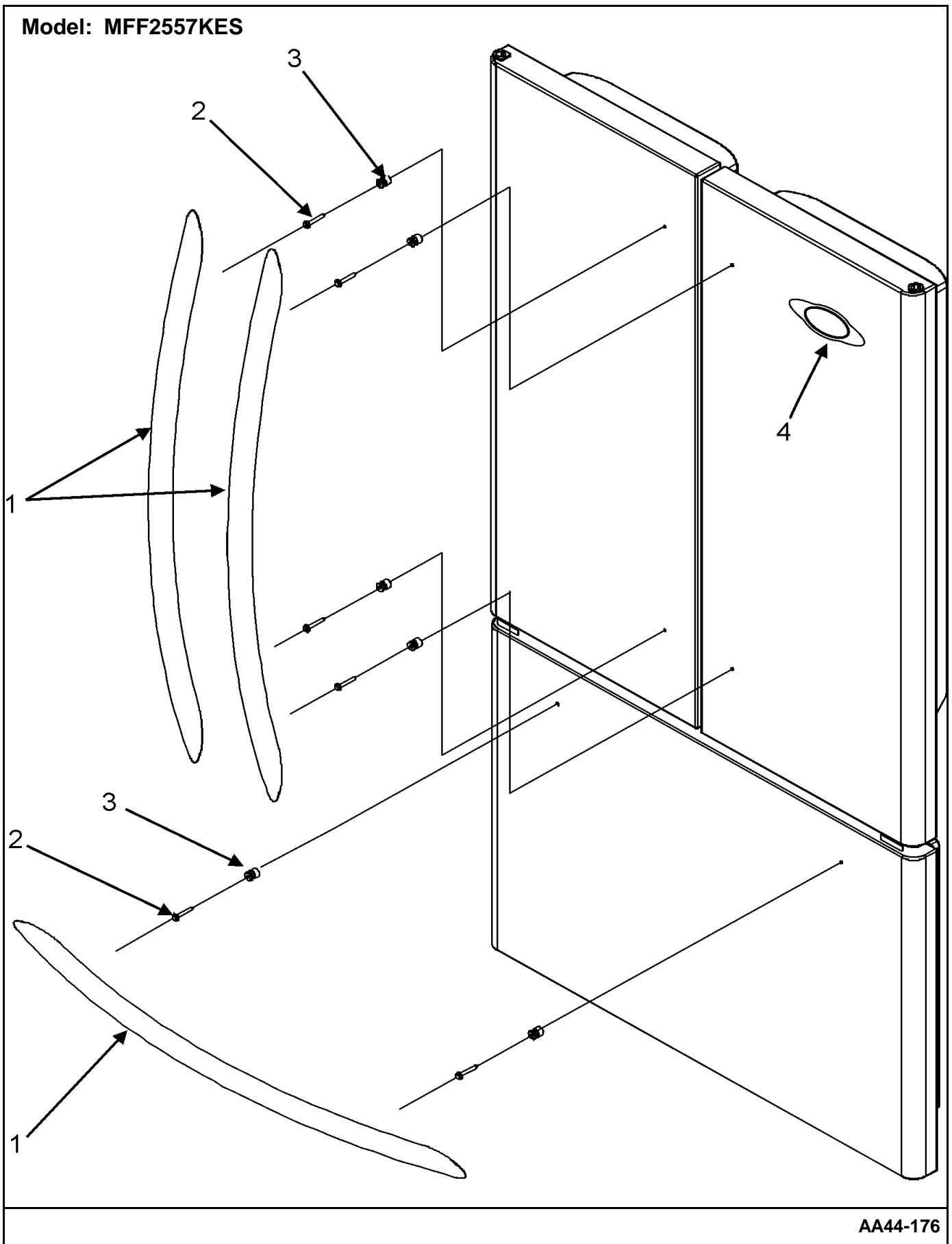

AA44-176

Section: HANDLES

No.	Part No.	Description	Series	Qty
1	67006391	HANDLE ASSY., DOOR (STNLS)	10	3
2	67002935	SCREW, MOUNT	10	6
3	67006113	MOUNT, HANDLE	10	6
4	67006439	NAMEPLATE	10	1

*Color Code (-)=Not Shown #=Series, Serial Prefix or Run No., N=Not Available

Section: LEFT REFRIGERATOR DOOR

Model: MFF2557KES

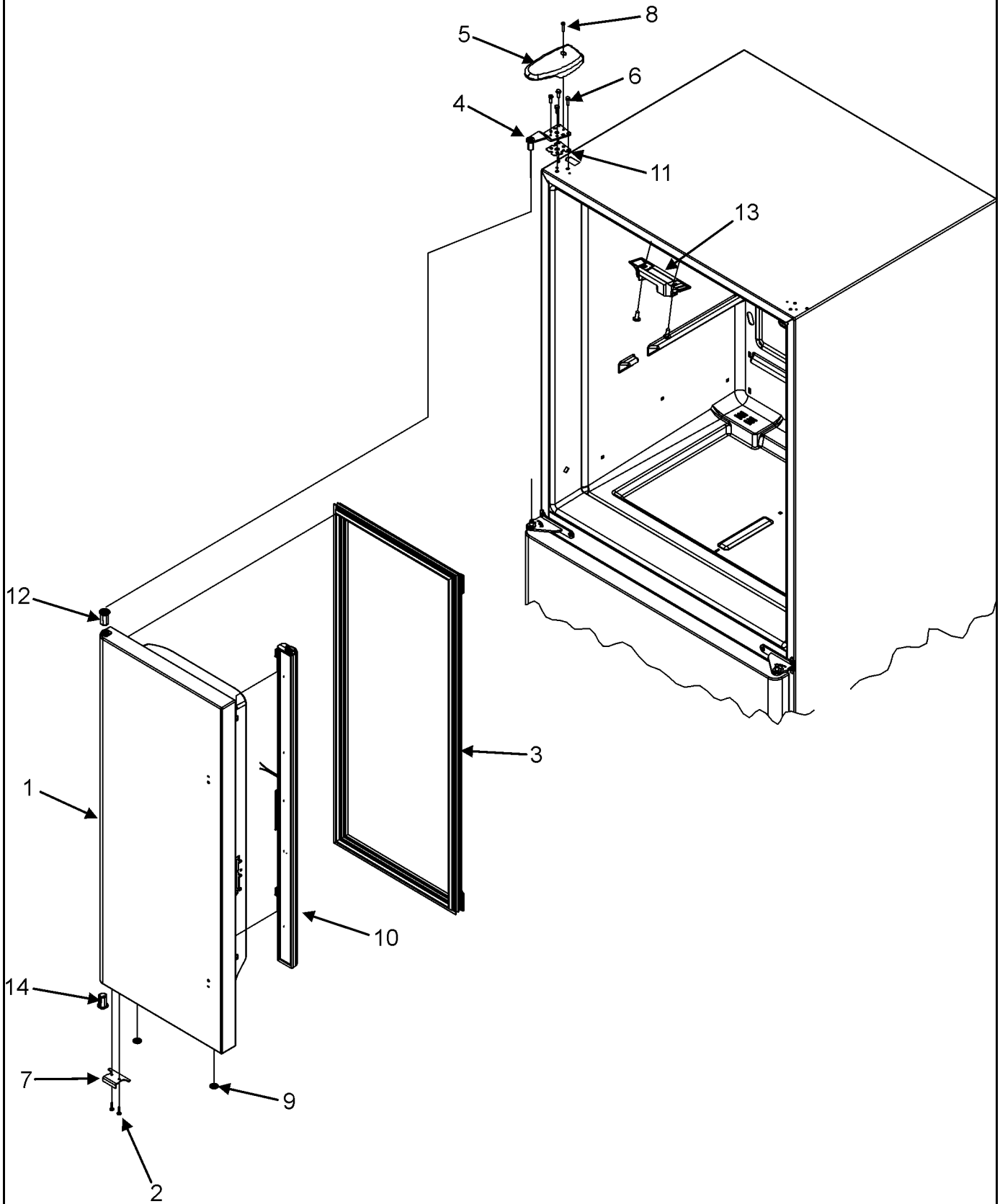

AA44-171

Section: LEFT REFRIGERATOR DOOR

No.	Part No.	Description	Series	Qty
1	67006590	DOOR ASSY.,LT REF FOAM (STNLS)	10	1
2	67006287	SCREW, SM Note: SCREW, DOOR STOP	10	2
3	67003547	GASKET, FRENCH DOOR (BLK)	10	1
4	12566603ED	HINGE, TOP (BLK)	10	1
5	12684201B	COVER, TOP HINGE (LT-BLK)	10	1
6	67006303	SCREW Note: SCREW, TOP HINGE	10	3
7	67006276	STOP, DOOR (BLK)	10	1
8	67006521	SCREW Note: SCREW, HINGE COVER	10	1
9	67004838	PLUG, VENT (BLK)	10	2
10	67003264	VERT MULLION ASSY (BLK)	10	1
-	67006786	SCREW, MULLION Note: SCREW, MULLION	10	1
11	12579702	SHIM, TOP HINGE	10	1
12	12395501B	BUSHING, DOOR (BLK) Note: BUSHING, TOP DOOR (BLK)	10	1
-	67006626	SCREW Note: SCREW, PIVOT BLOCK	10	2
13	67003405	BLOCK, PIVOT	10	1
14	67002721	BUSHING, DOOR (BLK) Note: BUSHING, BOTTOM DOOR (BLK)	10	1

*Color Code (-)=Not Shown #=Series, Serial Prefix or Run No., N=Not Available

Section: RIGHT REFRIGERATOR DOOR

Model: MFF2557KES

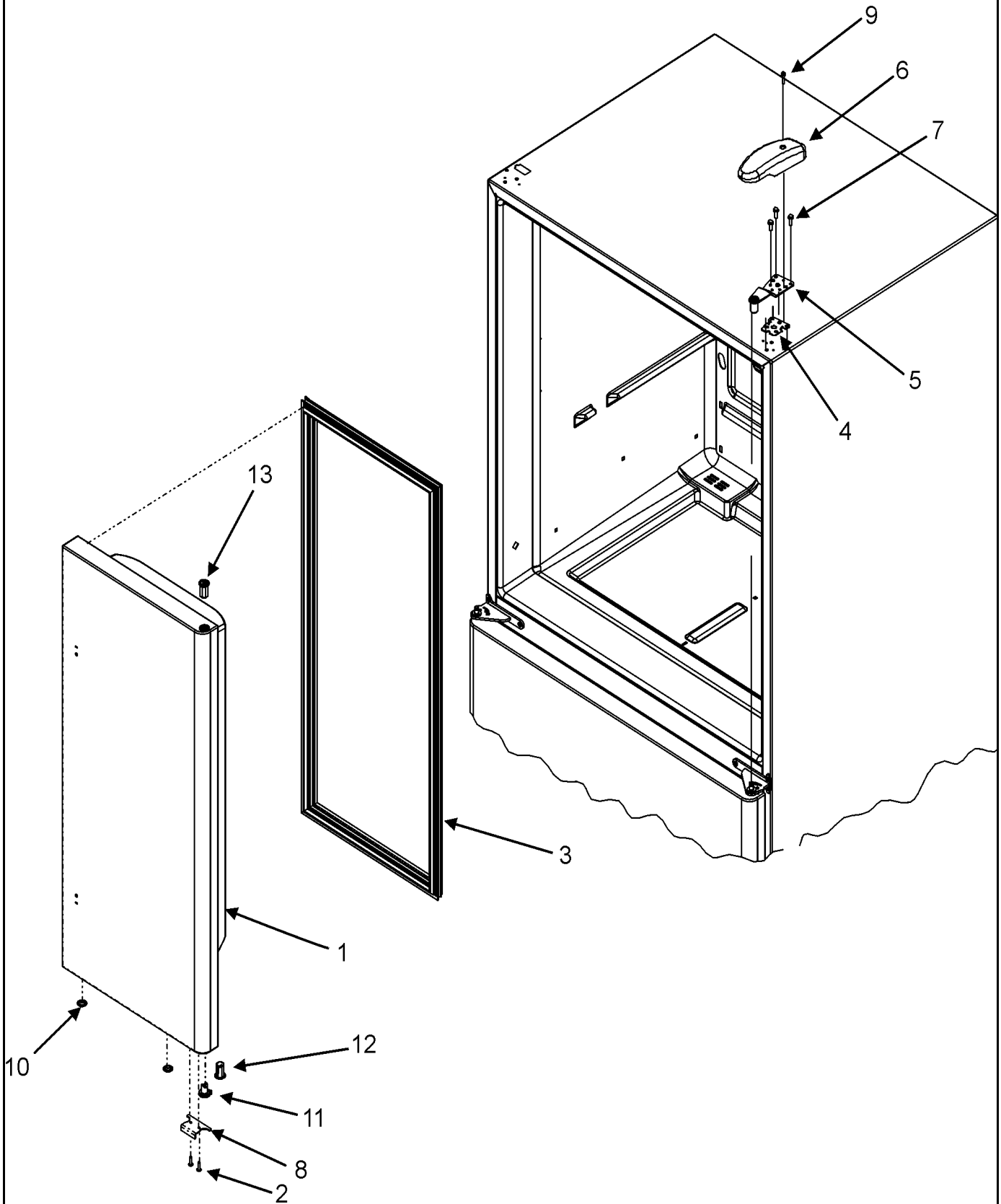

AA44-177

Section: RIGHT REFRIGERATOR DOOR

No.	Part No.	Description	Series	Qty
1	67006594	DOOR ASSY.,RT REF FOAM (STNLS)	10	1
2	67006287	SCREW, SM Note: SCREW, DOOR STOP	10	2
3	67003547	GASKET, FRENCH DOOR (BLK)	10	1
4	12579702	SHIM, TOP HINGE	10	1
5	67001011	HINGE, TOP (BLK)	10	1
6	12684202B	COVER, TOP HINGE (RT-BLK)	10	1
7	67006303	SCREW Note: SCREW, TOP HINGE	10	3
8	67006276	STOP, DOOR (BLK)	10	1
9	67006521	SCREW Note: SCREW, HINGE COVER	10	1
10	67004838	PLUG, VENT (BLK)	10	2
11	67003639	CLOSURE, DOOR (BLK)	10	1
12	67002731	BUSHING, DOOR (BLK) Note: BUSHING, BOTTOM DOOR (BLK)	10	1
13	67004978	BUSHING, DOOR (BLK) Note: BUSHING, TOP DOOR (BLK)	10	1

*Color Code (-)=Not Shown #=Series, Serial Prefix or Run No., N=Not Available

Section: FREEZER DOOR

Model: MFF2557KES

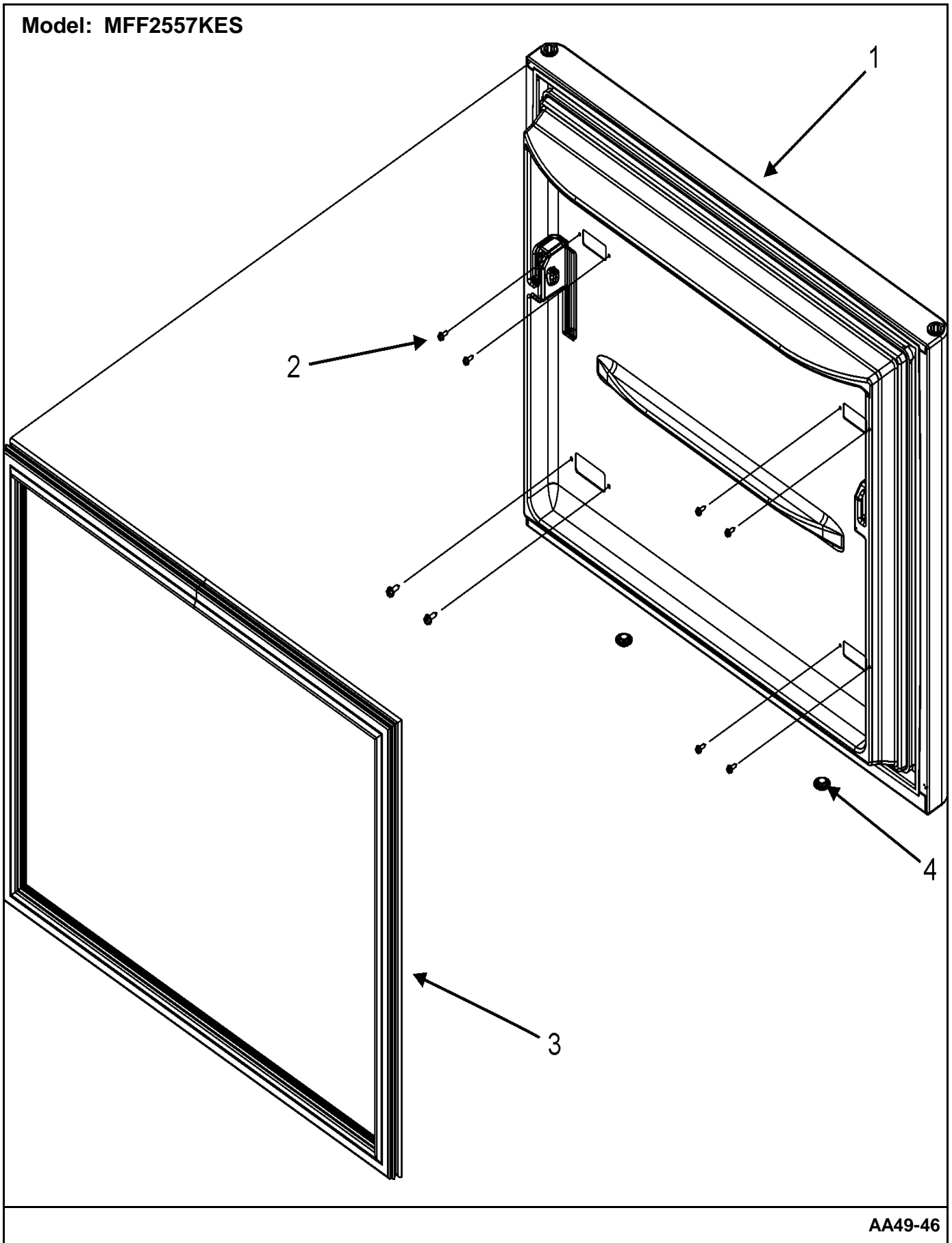

AA49-46

Section: FREEZER DOOR

No.	Part No.	Description	Series Qty	
1	67006596	DOOR ASSY., FRZ. FOAM (STNLS)	10	1
2	67006408	SCREW, SM	10	8
3	67003559	GASKET, FZ DOOR (BLK)	10	1
4	67004838	PLUG, VENT (BLK)	10	2

*Color Code (-)=Not Shown #=Series, Serial Prefix or Run No., N=Not Available

Section: REF DR STORAGE & CENTER HINGES

Model: MFF2557KES

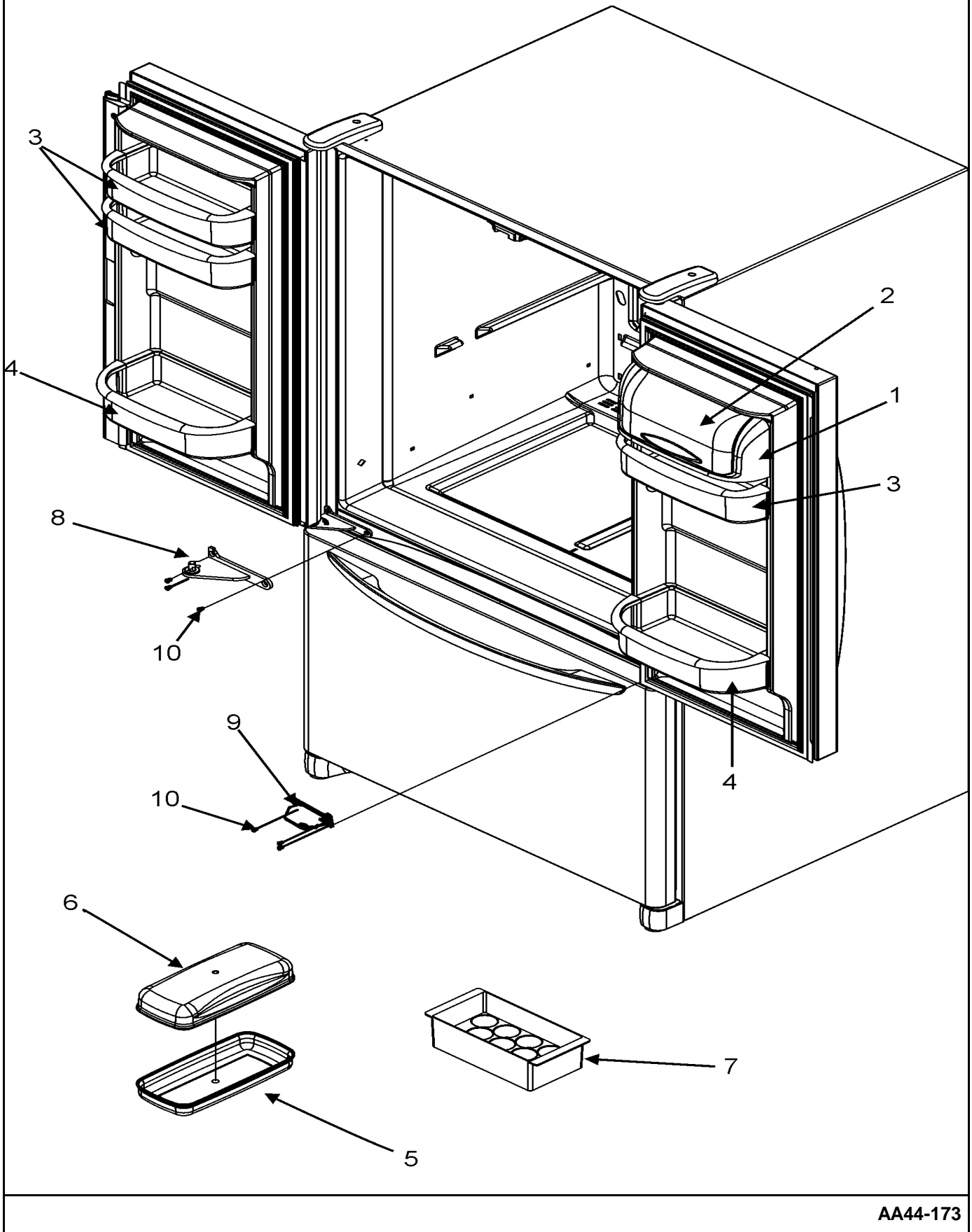

AA44-173

Section: REF DR STORAGE & CENTER HINGES

No.	Part No.	Description	Series	Qty
1	67001279	TRAY, DAIRY	10	1
2	67003637	DOOR, DAIRY	10	1
3	67001020	BUCKET, REF DR (MED)	10	3
4	67005250	BUCKET, REF DOOR	10	2
5	67004404	TRAY, BUTTER	10	1
6	67004405	LID, BUTTER TRAY	10	1
7	67215-2	TRAY, EGG	10	1
8	67006442	HINGE, CENTER (LT-BLK)	10	1
9	67006443	HINGE, CENTER (RT-BLK)	10	1
10	67006380	SCREW Note: SCREW, CENTER HINGE	10	6

*Color Code (-)=Not Shown #=Series, Serial Prefix or Run No., N=Not Available

Section: CONTROLS

Model: MFF2557KES

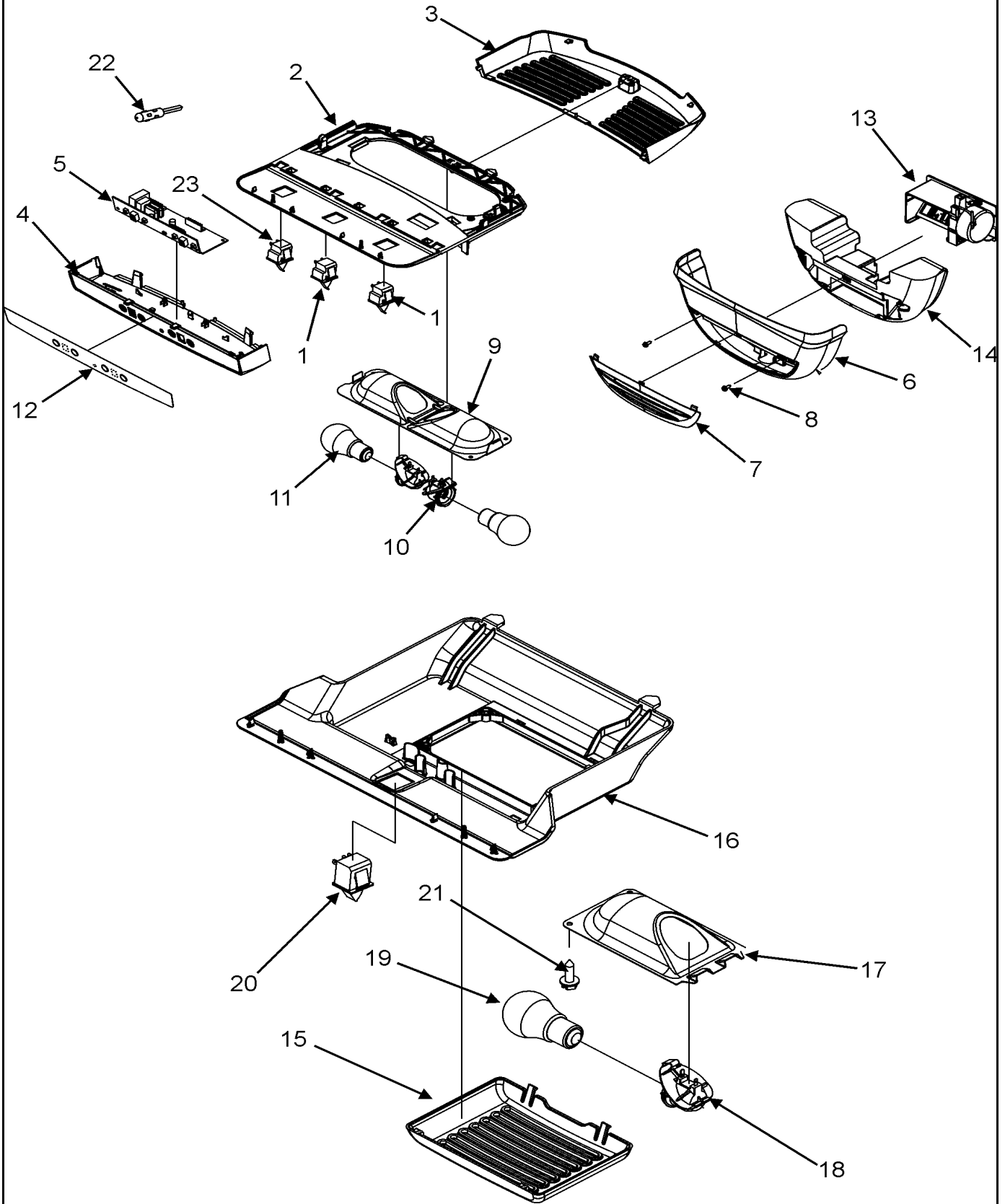

AA40-17

Section: CONTROLS

No.	Part No.	Description	Series	Qty
1	C3680310	SWITCH, LIGHT	10	2
2	67004078	MODULE, LIGHT	10	1
3	67003897	COVER, REF LIGHT	10	1
4	67004005	MODULE, REF CONTROL	10	1
5	67006740	BOARD, CONTROL	10	1
6	67003899	COVER, DAMPER	10	1
7	67003900	INSERT, DAMPER COVER	10	1
8	67006602	SCREW Note: SCREW, DAMPER BASE	10	2
9	67003901	HOUSING, LIGHT	10	1
10	12570701	SOCKET, LIGHT	10	2
11	67003883	BULB, LIGHT *	10	2
12	67004642	OVERLAY, CONTROL MODULE	10	1
13	67006116	DAMPER, CONTROL (W/HARNESS)	10	1
14	67006604	INSULATION, DAMPER CONTROL	10	1
15	67003905	COVER, FZ LIGHT	10	1
16	67003906	MODULE, FZ CONTROL	10	1
17	67001035	HOUSING, LIGHT	10	1
18	12570701	SOCKET, LIGHT	10	1
19	67003883	BULB, LIGHT *	10	1
20	67005653	SWITCH, LIGHT/INTLK	10	1
21	67006530	SCREW, TC Note: SCREW, HOUSING	10	1
22	12002355	THERMISTOR KIT	10	1
23	67003940	SWITCH, ENERGY SAVER	10	1
-	67004032	HARNESS, FF CONTROL	10	1
-	67006094	HARNESS, FZ MODULE	10	1

*Color Code (-)=Not Shown #=Series, Serial Prefix or Run No., N=Not Available

Section: REFRIGERATOR SHELVES

Model: MFF2557KES

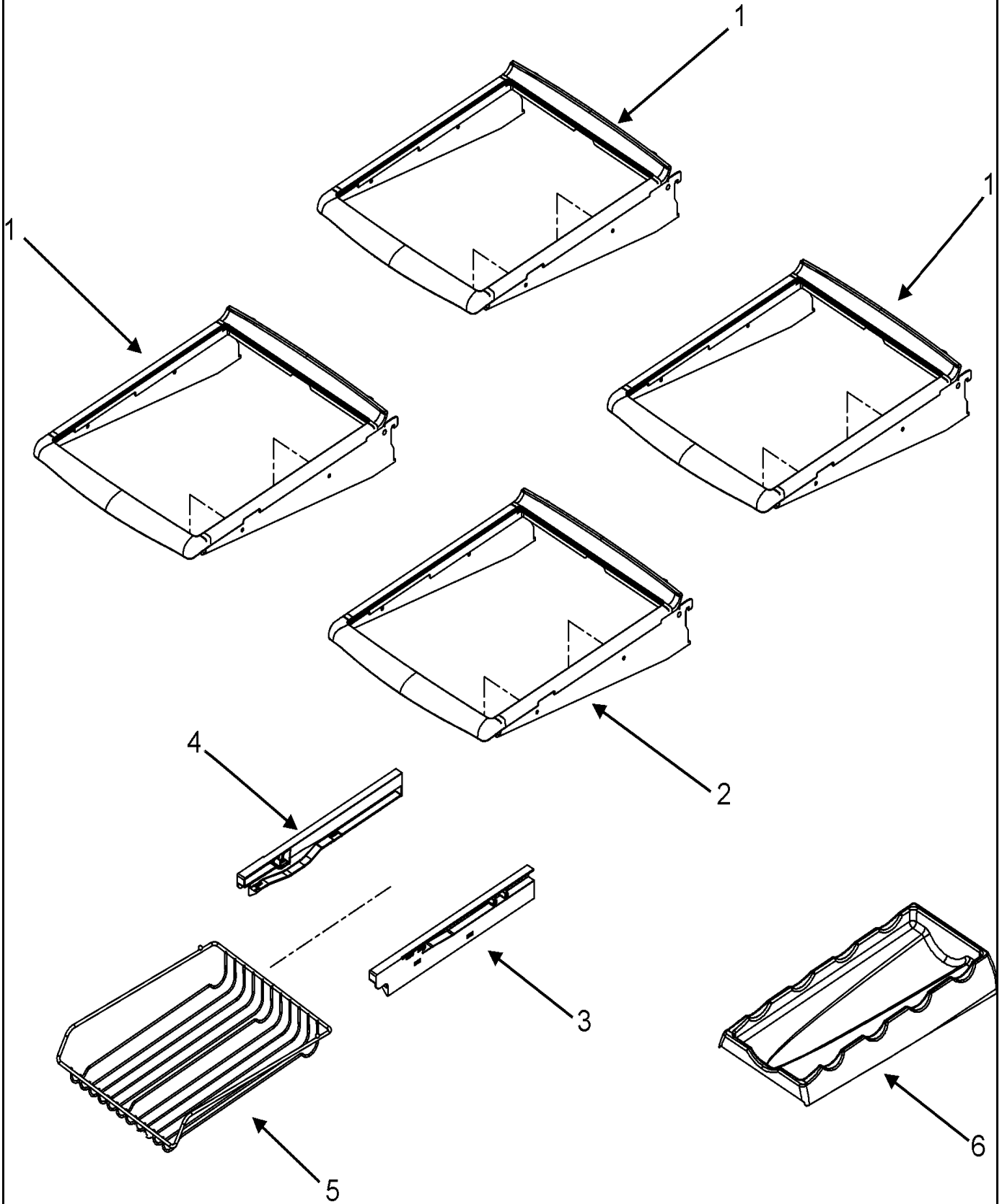

AA46-96

Section: REFRIGERATOR SHELVES

No.	Part No.	Description	Series	Qty
1	67004435	SHELF, STATIONARY	10	3
2	67004435	SHELF, STATIONARY	10	1
3	67001053	GLIDE (RT)	10	1
-	67006626	SCREW Note: SCREW, GLIDE	10	2
-	67006626	SCREW Note: SCREW, GLIDE	10	2
4	67001054	GLIDE (LT)	10	1
5	67004585	RACK, CAN	10	1
6	67001656	TRIVET, BOTTLE	10	1

*Color Code (-)=Not Shown #=Series, Serial Prefix or Run No., N=Not Available

Section: CRISPER ASSEMBLY

Model: MFF2557KES

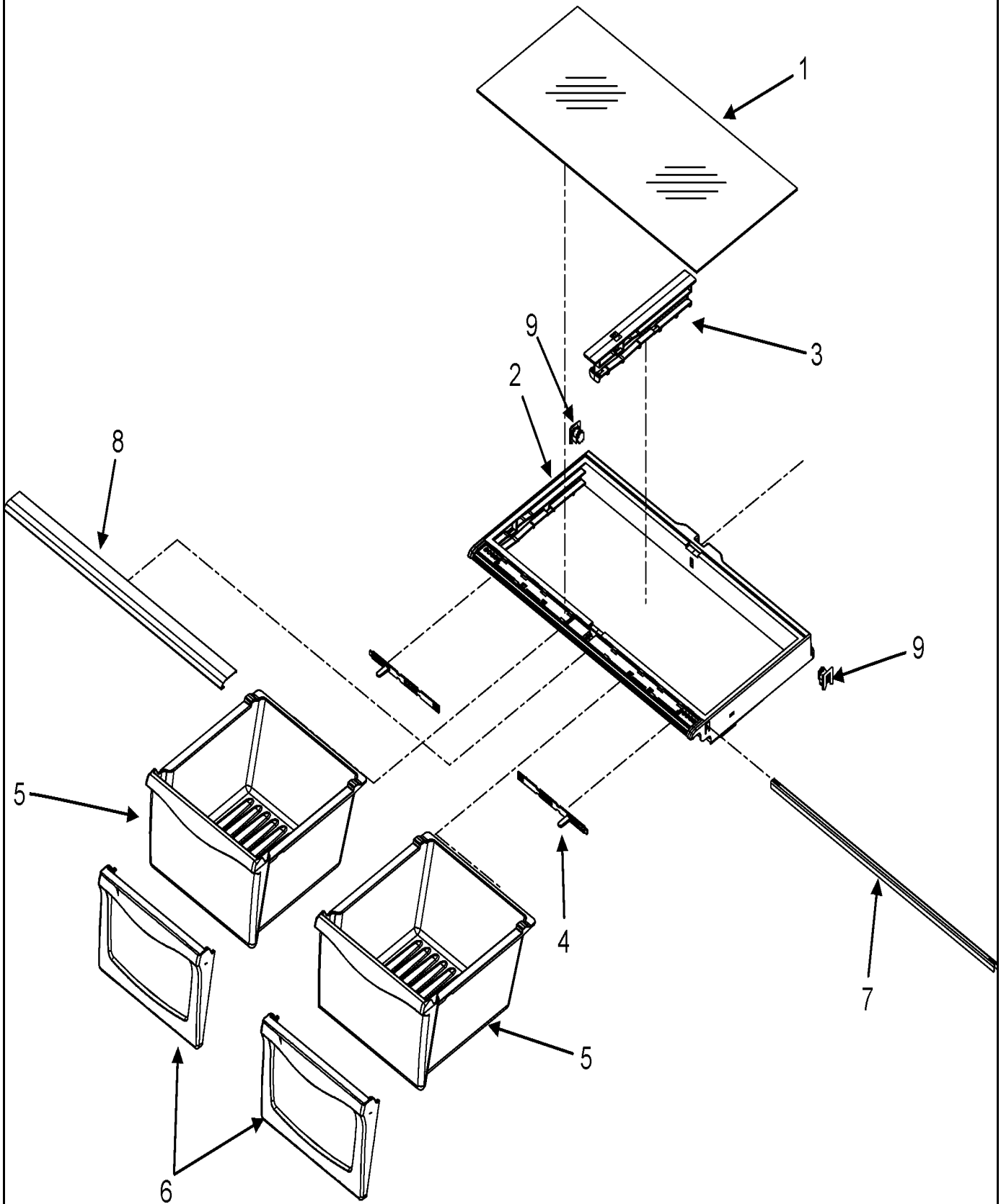

AA46-120

Section: CRISPER ASSEMBLY

No.	Part No.	Description	Series	Qty
1	67003852	GLASS, CRISPER	10	1
2	67003854	FRAME, CRISPER	10	1
3	67004514	RAIL, CENTER CRISPER	10	1
4	67005864	SLIDE, HUMIDITY CONTROL	10	2
5	67004515	PAN, CRISPER	10	2
6	67005923	FRONT, CRISPER PAN	10	2
7	67002748	BRACE, CRISPER E-CT	10	1
8	67004510	EXTR, FRONT CRISPER	10	1
9	12603701	SUPPORT, CRISPER FRAME	10	2

*Color Code (-)=Not Shown #=Series, Serial Prefix or Run No., N=Not Available

Section: PANTRY ASSEMBLY

Model: MFF2557KES

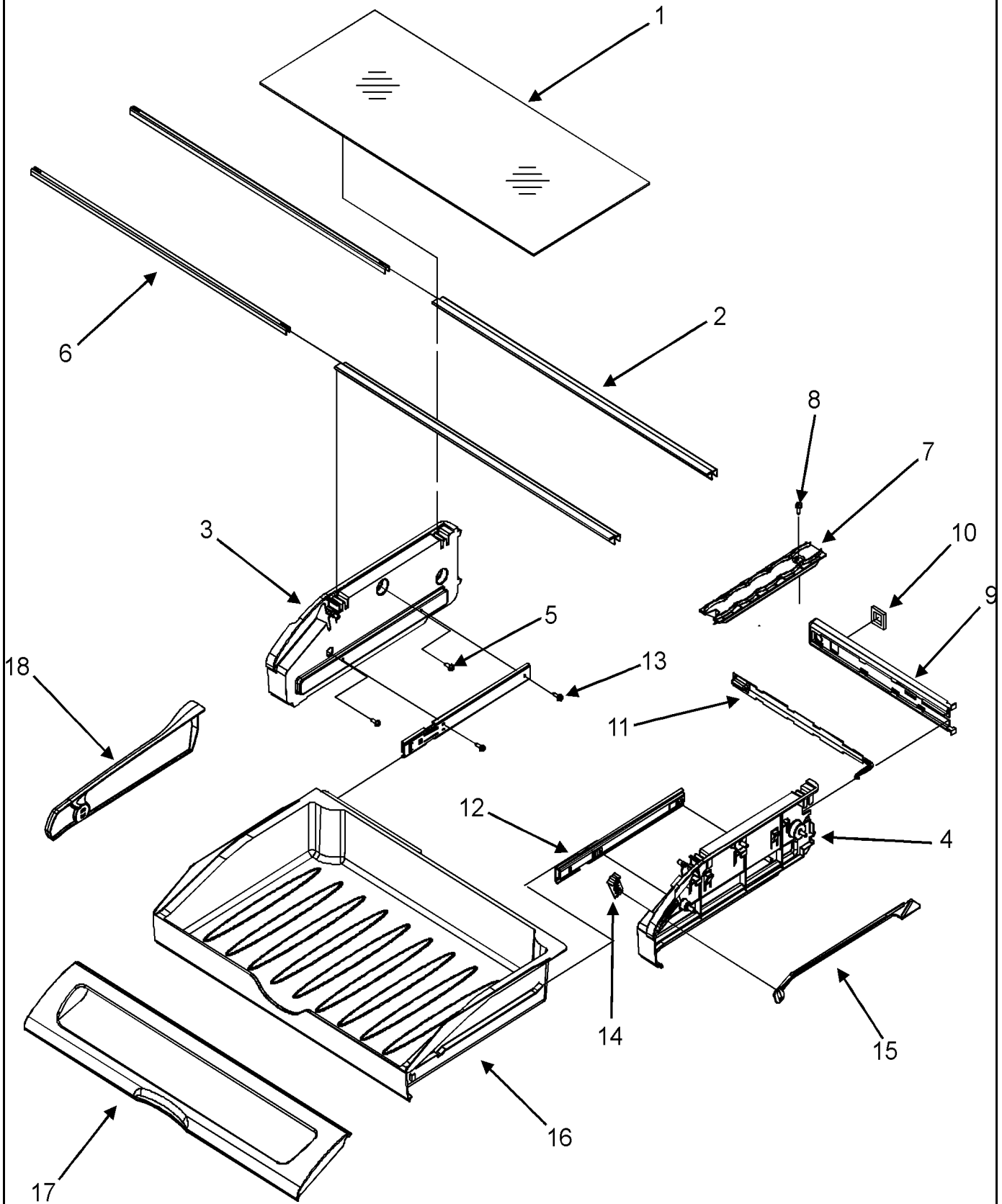

AA46-80

Section: PANTRY ASSEMBLY

No.	Part No.	Description	Series	Qty
1	67002761	GLASS, PANTRY	10	1
2	67006010	EXTR, GLASS SUPPORT	10	2
3	67005863	END CAP, PANTRY (LT)	10	1
4	67005858	END CAP, PANTRY (RT)	10	1
5	67006415	SCREW Note: SCREW, END CAP	10	6
6	67002330	BRACE, PANTRY	10	2
7	67001719	TRACK, DELI DRAWER	10	1
8	67006400	SCREW, SM Note: SCREW, TRACK	10	1
9	67005625	HOUSING, CONTROL	10	1
10	67002329	GASKET, PANTRY	10	1
11	67003793	SLIDE, TEMP CONTROL	10	1
12	67006219	GLIDE, PANTRY DRAWER *	10	2
13	67006287	SCREW, SM Note: SCREW, GLIDE	10	4
14	67003791	KNOB, TEMP CONTROL	10	1
15	67003795	BAR, TEMP CONTROL	10	1
16	67003531	DRAWER, PANTRY	10	1
17	67005903	LID, PANTRY	10	1
18	67002759	DIVIDER, PANTRY	10	1

*Color Code (-)=Not Shown #=Series, Serial Prefix or Run No., N=Not Available

Section: EVAPORATOR AREA & ROLLERS

Model: MFF2557KES

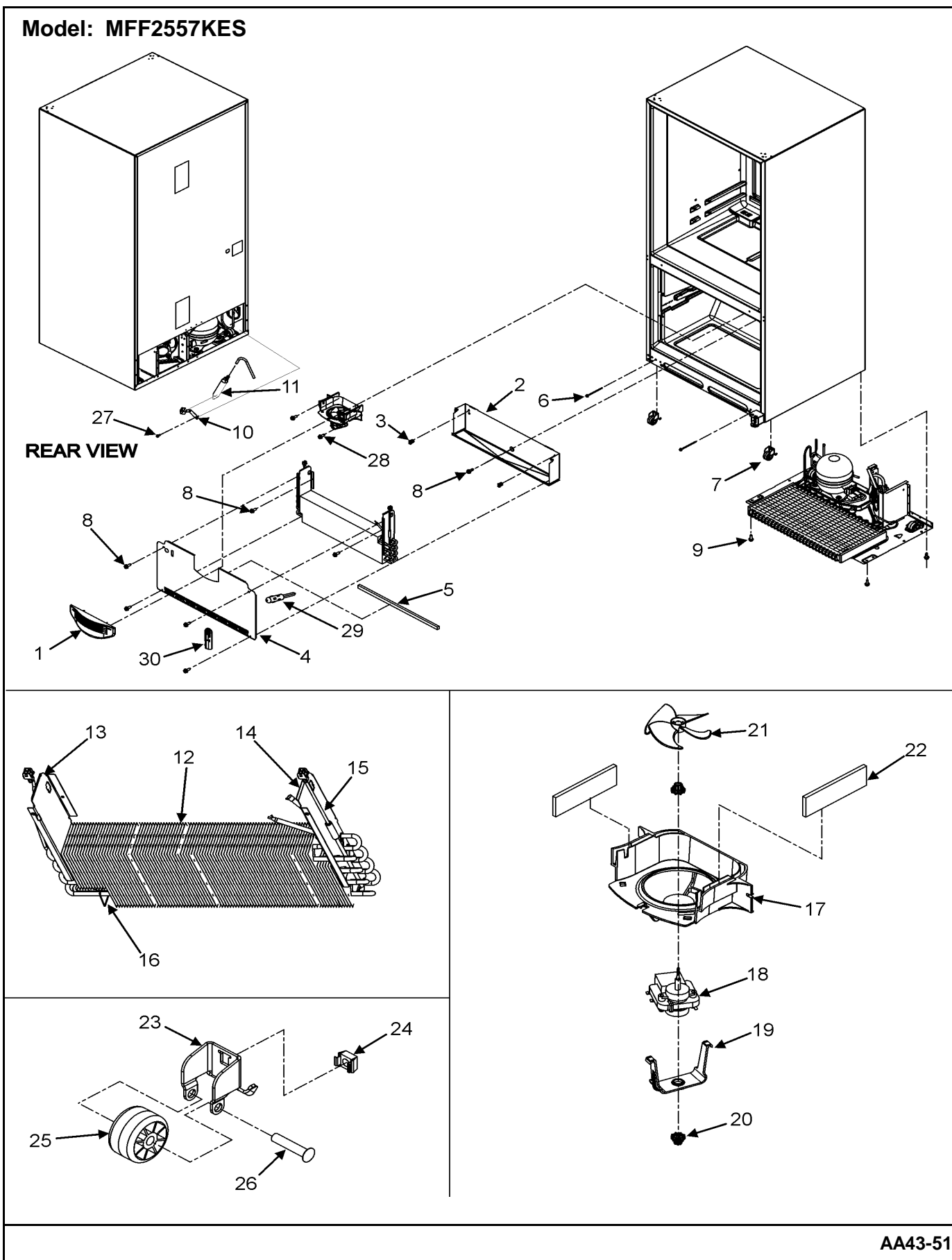

Section: EVAPORATOR AREA & ROLLERS

No.	Part No.	Description	Series	Qty
1	67006609	GRILLE, FZ AIR *	10	1
2	67002490	TRAY, DRIP E-CT Note: TRAY, DRIP	10	1
3	10623002	CLIP, EVAPORATOR	10	2
4	67005873	COVER, EVAPORATOR Note: COVER-EVAP	10	1
5	67002492	GASKET	10	1
6	67006611	BOLT, ROLLER ADJ Note: SCREW, ROLLER ADJ	10	2
7	67002227	ROLLER BRACKET ASSY	10	2
8	67006425	SCREW, SM Note: SCREW	10	7
9	67006573	SCREW Note: SCREW	10	4
10	10547002	CLIP, DRIER	10	1
11	B2150504	DRIER	10	1
12	12002041	KIT, EVAP REPLACEMENT Note: EVAPORATOR KIT (INCL. HEAT SHIELD, EVAP. & INSTR. SHEET).	10	1
13	67001083	DAM, LEFT RETURN	10	1
14	67001084	DAM, RIGHT RETURN	10	1
15	67002493	HEATER, DEFROST Note: HEATER, DEFROST	10	1
16	10428101	CLIP, EVAP HEATER	10	2
17	67002777	SHROUD, EVAP FAN	10	1
18	67003917	MOTOR, EVAP FAN	10	1
19	67002779	CLIP, EVAP MOTOR	10	1
20	67002780	GROMMET, FAN MOTOR (BLK)	10	2
21	67005695	FAN, EVAP Note: FAN, EVAP	10	1
22	67001291	GASKET, FOAM	10	2
23	12456801	BRACKET, ROLLER	10	2
24	M0286708	NUT, SPEED	10	2
25	67005127	ROLLER	10	2
26	M1205302	RIVET	10	2
27	67006737	SCREW Note: SCREW	10	1
28	67006287	SCREW, SM Note: SCREW, FAN ASSY.	10	2
29	12002355	THERMISTOR KIT	10	1
30	67003924	COVER, FZ THERMISTOR	10	1
-	67003426	THERMOSTAT, DEFROST	10	1
-	67004080	HARNESS, EVAP HEATER	10	1

*Color Code (-)=Not Shown #=Series, Serial Prefix or Run No., N=Not Available

Section: ICE MAKER

Model: MFF2557KES

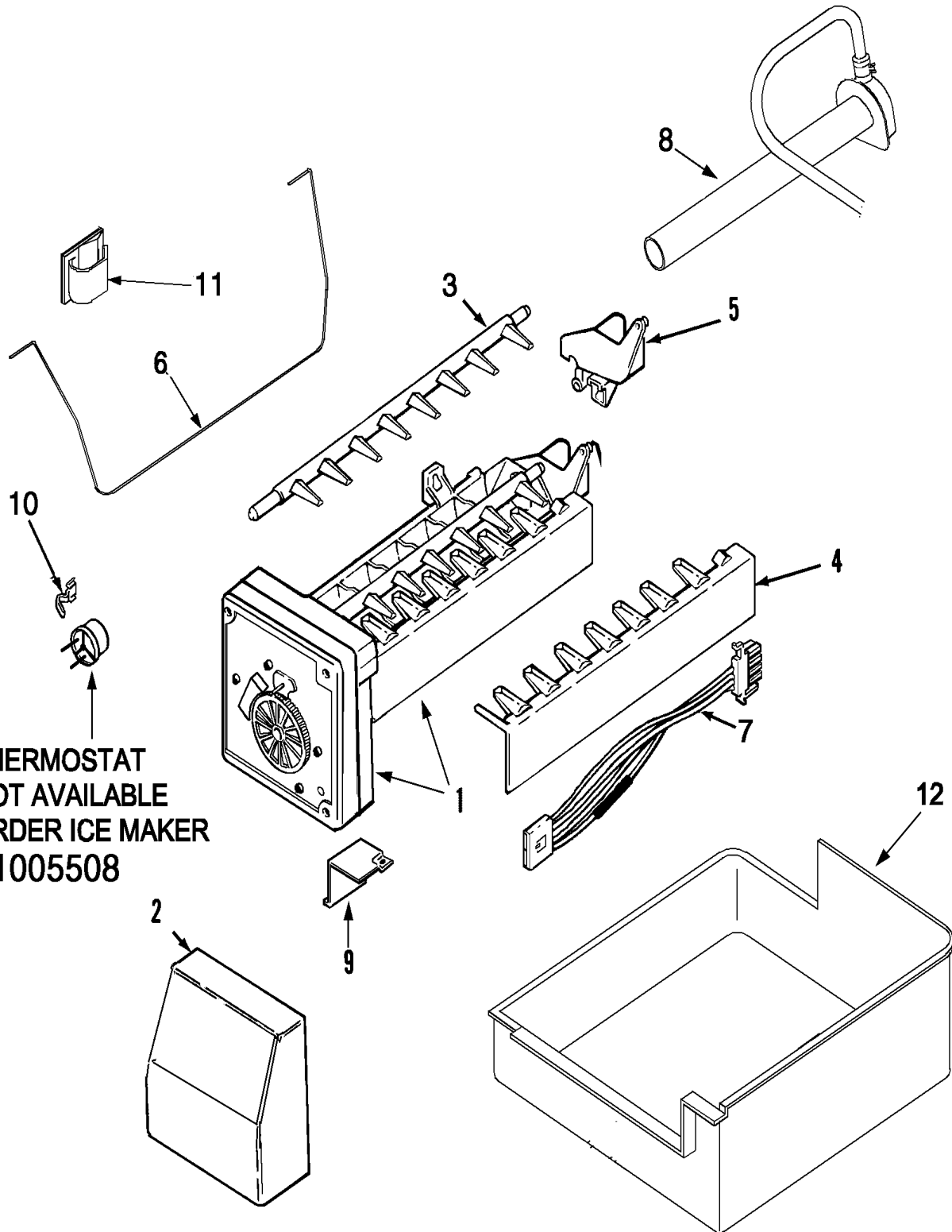

THERMOSTAT
NOT AVAILABLE
ORDER ICE MAKER
61005508

Section: ICE MAKER

No.	Part No.	Description	Series	Qty
-	67002823	BRKT, ICE MAKER	10	1
-	67006287	SCREW, SM Note: SCREW, ICE MAKER	10	3
1	61005508	ICE MAKER ASSY.	10	1
2	67004710	COVER, ICE MAKER	10	1
3	95101-1	EJECTOR, ICE	10	1
4	95102-1	STRIPPER, ICE	10	1
5	95100-1	INLET, WATER	10	1
6	67004028	ARM, IM SHUTOFF	10	1
7	67006614	HARNESS, ICE MAKER	10	1
8	10463201	ELBOW, FILL TUBE	10	1
9	95107-1	BRACKET, MODULE & HEATER	10	1
10	95104-1	RETAINER, THERMOSTAT	10	1
11	M0104106	CLIP	10	2
12	67001255	PAN, ICE	10	1
-	10244904	COUPLING	10	1
-	R0131235	ICE MAKER HOOK UP KIT Note: INCLUDES 1/4" OD X 25' COPPER TUBING, SADDLE VALVE (NON PIERCING), AND 1/4" OD COMPRESSION NUT AND SLEEVE.	10	1

*Color Code (-)=Not Shown #=Series, Serial Prefix or Run No., N=Not Available

Section: SUPPLEMENTAL INFORMATION

No.	Part No.	Description	Series	Qty
-	12828147	MANUAL, USE & CARE	10	1
-	16022769	SVC MAN, BTM MT	10	1
-	16026954	TECH SHT, BTM MT	10	1
-	67006824	TAG, ENERGY	10	1

*Color Code (-)=Not Shown #=Series, Serial Prefix or Run No., N=Not Available

Section: INTERIOR CABINET/TOE GRILLE/FRZ SHELVES

Model: MFF2557KES

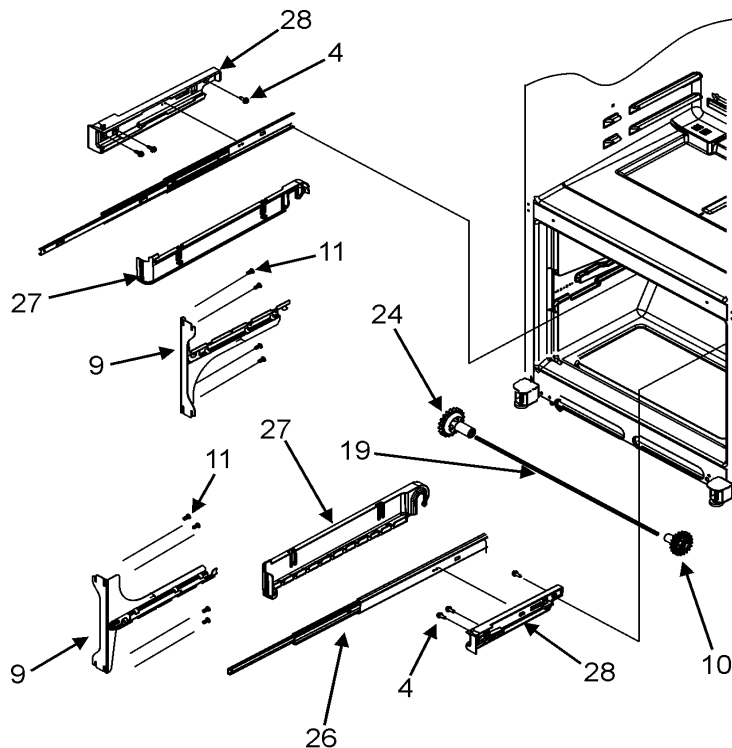
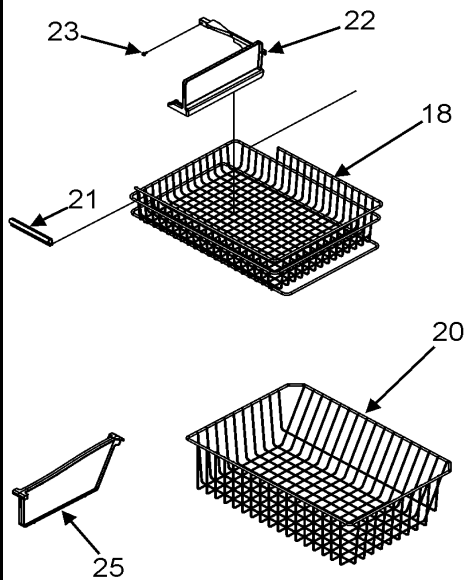
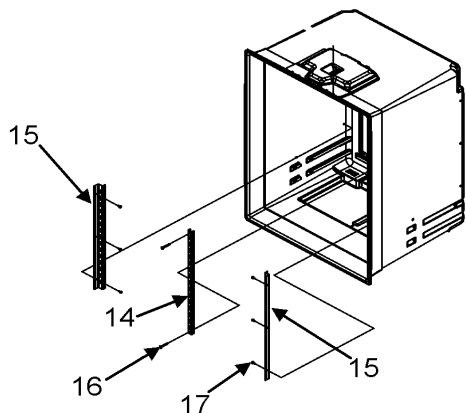
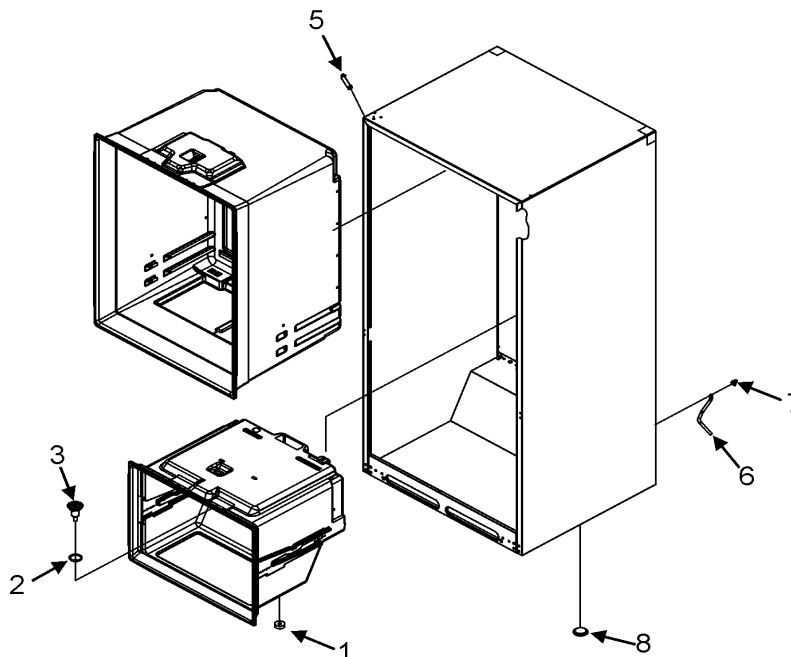
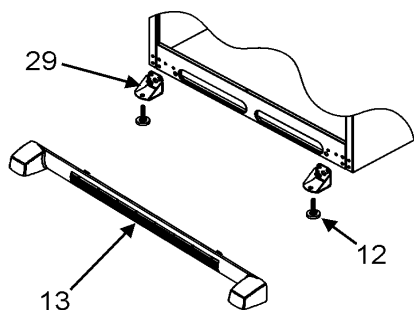

AA43-89

Section: INTERIOR CABINET/TOE GRILLE/FRZ SHELV

No.	Part No.	Description	Series	Qty
1	B8381501	GASKET, DRAIN TUBE	10	1
2	M0500703	SEAL, O RING	10	1
3	D7753903	FUNNEL, DRAIN	10	1
4	67006406	SCREW, SM/HEX HEAD Note: SCREW, ADAPTER	10	6
5	67003485	COVER, CORNER (BLK)	10	2
6	67001066	TUBE, DRAIN	10	1
7	67001067	CLIP, DRAIN TUBE	10	1
8	A3076901	PLUG, BUTTON	10	1
9	67004012	BRACKET, DRAWER SLIDE (LT)	10	1
9	67004013	BRACKET, DRAWER SLIDE (RT)	10	1
10	67004430	GEAR (RT)	10	1
11	67006473	SCREW SM/HEX Note: SCREW, BRACKET	10	8
12	67003868	BRAKE, FOOT	10	2
13	67006375	GRILLE, TOE (BLK)	10	1
-	12627302	CLIP, TOE GRILLE	10	2
14	67001073	LADDER, CENTER Note: RAIL, SEHLF SUPPORT (CTR)	10	1
15	67002489	LADDER, L/R SIDE Note: RAIL, SHELF SUPPORT (LT/RT)	10	2
16	67006360	SCREW Note: SCREW, CTR RAIL	10	2
17	67006400	SCREW, SM Note: SCREW, LT/RT RAIL	10	6
18	67004987	BASKET, FRZ. (UPR)	10	1
19	67004017	SHAFT, RACK	10	1
20	67004079	BASKET, FRZ. (LWR)	10	1
21	10508506	HANDLE, BASKET/SHELF Note: HANDLE, BASKET	10	1
22	67004127	DIVIDER, BASKET (UPPER) Note: DIVIDER, BASKET (UPR)	10	1
23	67006608	SCREW Note: SCREW, UPR DIVIDER	10	1
24	67004429	GEAR (LT)	10	1
25	67006103	DIVIDER, BASKET (LWR)	10	1
26	67006607	SLIDE, DRAWER	10	2
27	67004014	CRADLE, BASKET (LT)	10	1
27	67004015	CRADLE, BASKET (RT)	10	1
28	67004865	ADAPTER, SIDE (RT)	10	1
28	67004864	ADAPTER, SIDE (LT)	10	1
-	67006491	SCREW Note: SCREW, BRACKET	10	8
29	67006112	BRACKET, FOOT CABINET	10	2

*Color Code (-)=Not Shown #=Series, Serial Prefix or Run No., N=Not Available

Section: COMPRESSOR

Model: MFF2557KES

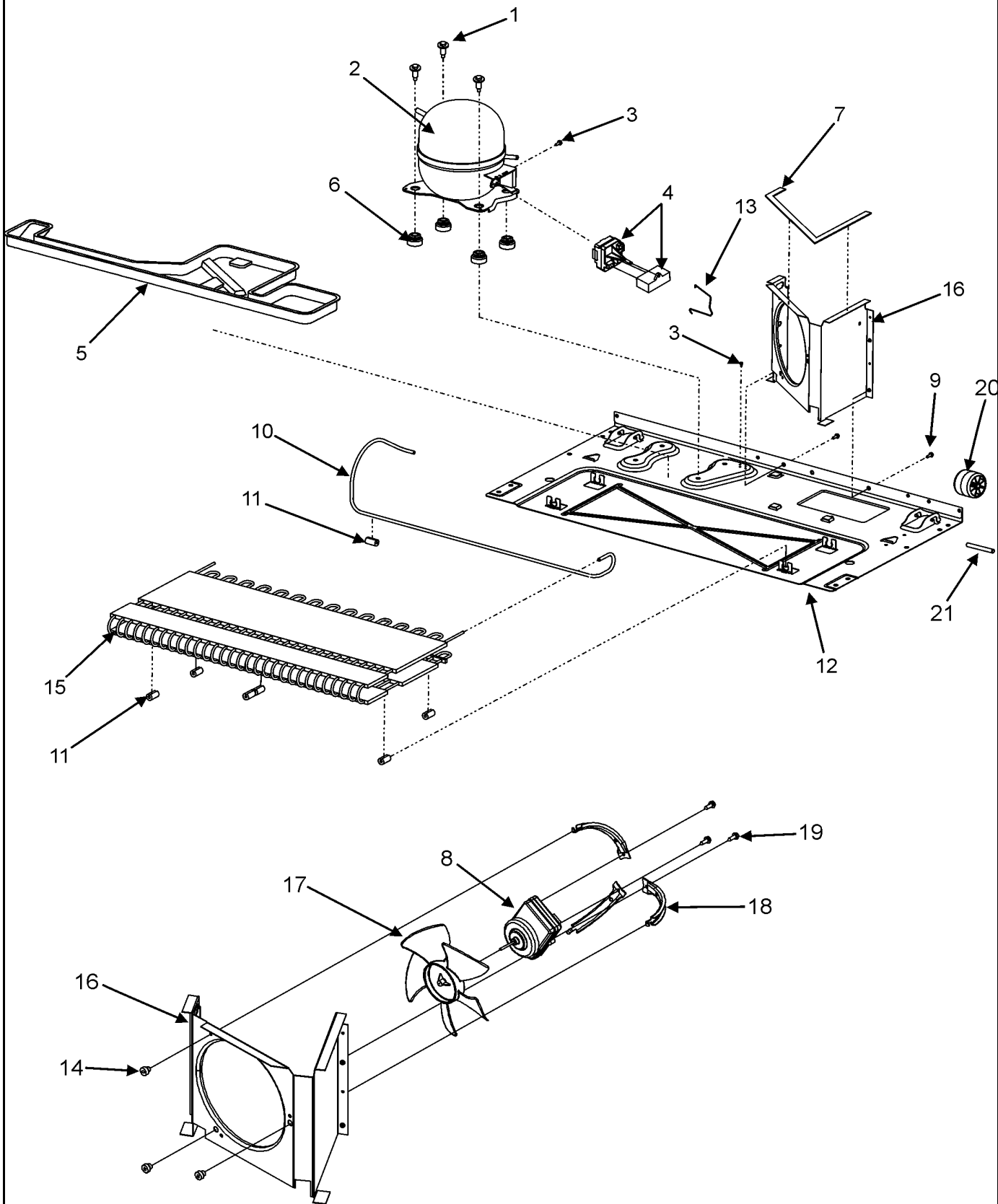

AA41-60

Section: COMPRESSOR

No.	Part No.	Description	Series	Qty
1	67006432	SCREW, SHOULDER Note: SCREW, COMPRESSOR	10	3
2	12002634	KIT, COMPRESSOR Note: COMPRESSOR KIT (INCL. COMPRESSOR, OVERLOAD & RELAY, CAPACITOR, BALE STRAP, GROMMETS, & INSTR. SHEET)	10	1
3	67006433	SCREW Note: SCREW, GROUND	10	2
4	67005560	OVERLOAD/RELAY W/CAPACITOR	10	1
5	67004464	PAN, DRAIN	10	1
6	67003493	GROMMET, COMPRESSOR	10	4
7	61003210	SEAL Note: SEAL, CONDENSOR SHROUD	10	1
8	67004432	MOTOR, CONDENSER FAN	10	1
9	67006425	SCREW, SM Note: SCREW	10	2
10	67004700	TUBE, DISCHARGE	10	1
11	67005680	GROMMET, CONDENSER	10	7
12	67005889	PAN, BASE	10	1
13	12576801	STRAP, BALE	10	1
14	61004743	GROMMET, BRACKET	10	3
15	67006131	CONDENSER	10	1
16	67001090	SHROUD, CONDENSER FAN	10	1
17	67004952	BLADE, COND FAN	10	1
18	67004953	BRACKET, COND MOTOR	10	3
19	67004954	SCREW Note: SCREW, BRACKET	10	3
20	67005149	ROLLER	10	2
21	67006434	AXLE, ROLLER	10	2
-	67005251	HARNES, MC	10	1

*Color Code (-)=Not Shown #=Series, Serial Prefix or Run No., N=Not Available

Section: CABINET BACK

Model: MFF2557KES

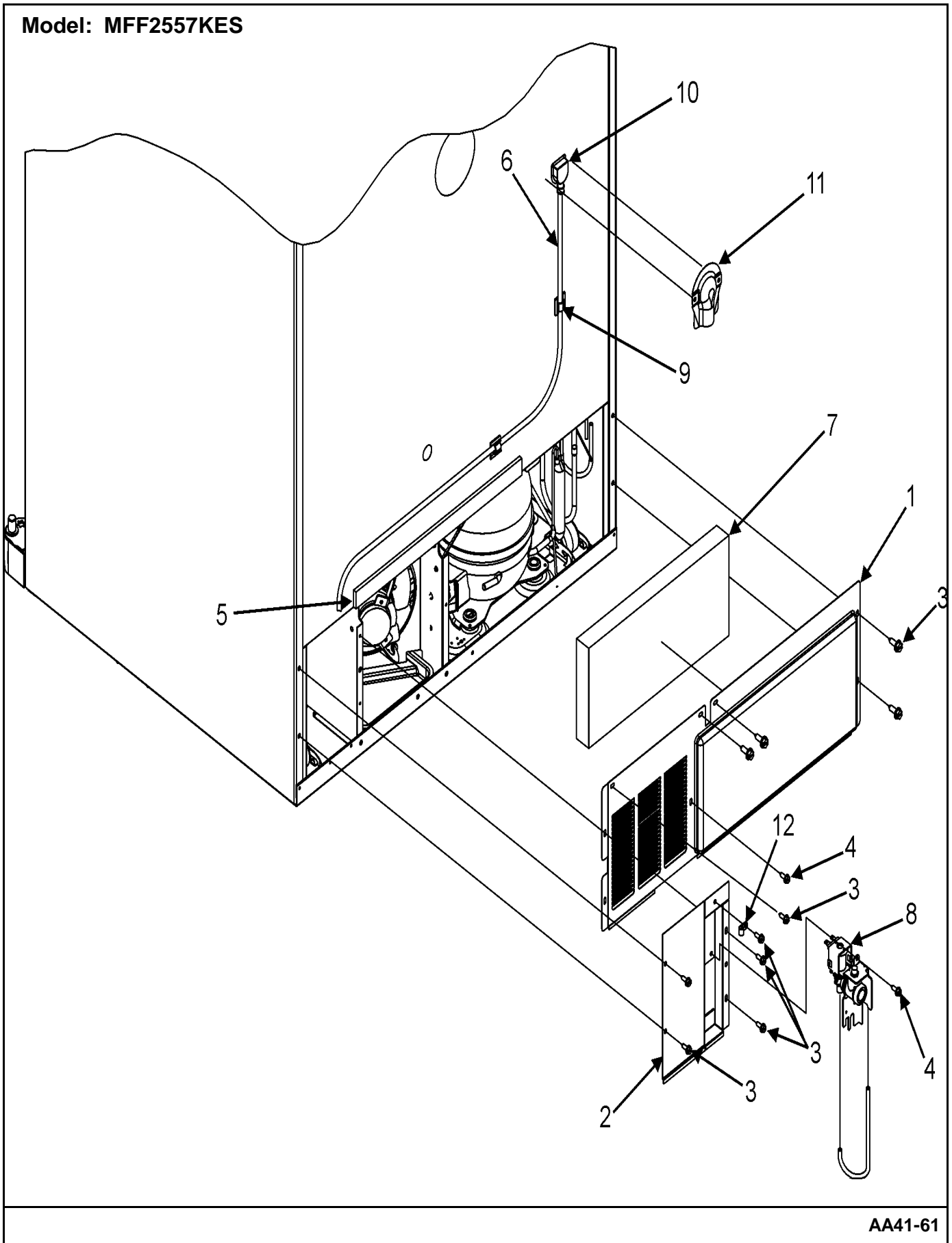

AA41-61

Section: CABINET BACK

No.	Part No.	Description	Series	Qty
1	67006101	COVER, MC BACK	10	1
2	12479803	COVER, WATER VALVE	10	1
3	67006425	SCREW, SM Note: SCREW, COVER	10	11
4	67006662	SCREW Note: SCREW, WATER VALVE	10	1
5	B5759649	GASKET, MC BACK	10	1
6	67003729	TUBE, PLASTIC	10	1
7	67003796	FIBER, ACOUSTIC	10	1
8	67003753	VALVE, WATER	10	1
9	M0104106	CLIP	10	3
10	10463201	ELBOW, FILL TUBE	10	1
-	M0114003	CLIP, SPEED	10	1
11	67003331	COVER, WATER LINE	10	1
12	M0108105	CLAMP, TUBE	10	1
-	A3223101	INSERT, PLASTIC TUBE	10	1
-	67006506	CORD, POWER	10	1

*Color Code (-)=Not Shown #=Series, Serial Prefix or Run No., N=Not Available

Section: WIRING INFORMATION

Model: MFF2557KES

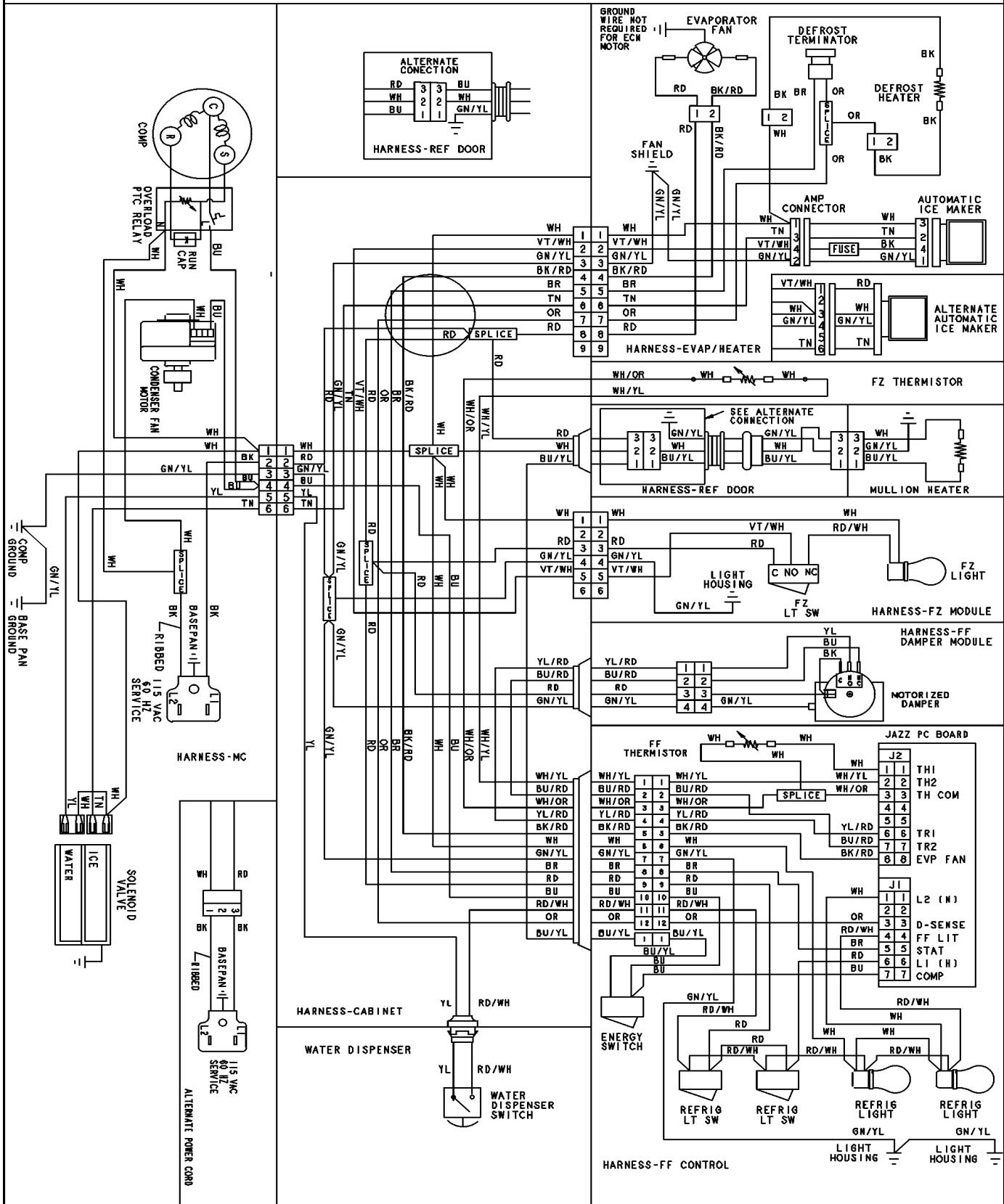

15003922

