

# WASHER

## Repair Parts List

MODEL NUMBER

MAH55FLBWW

When requesting service or ordering parts, always provide the following information:

- Product Type
- Part Number
- Model Number
- Part Description

**MAYTAG**®

©2005 Maytag Services

Section: CONTROL PANEL

Model: MAH55FLBWW

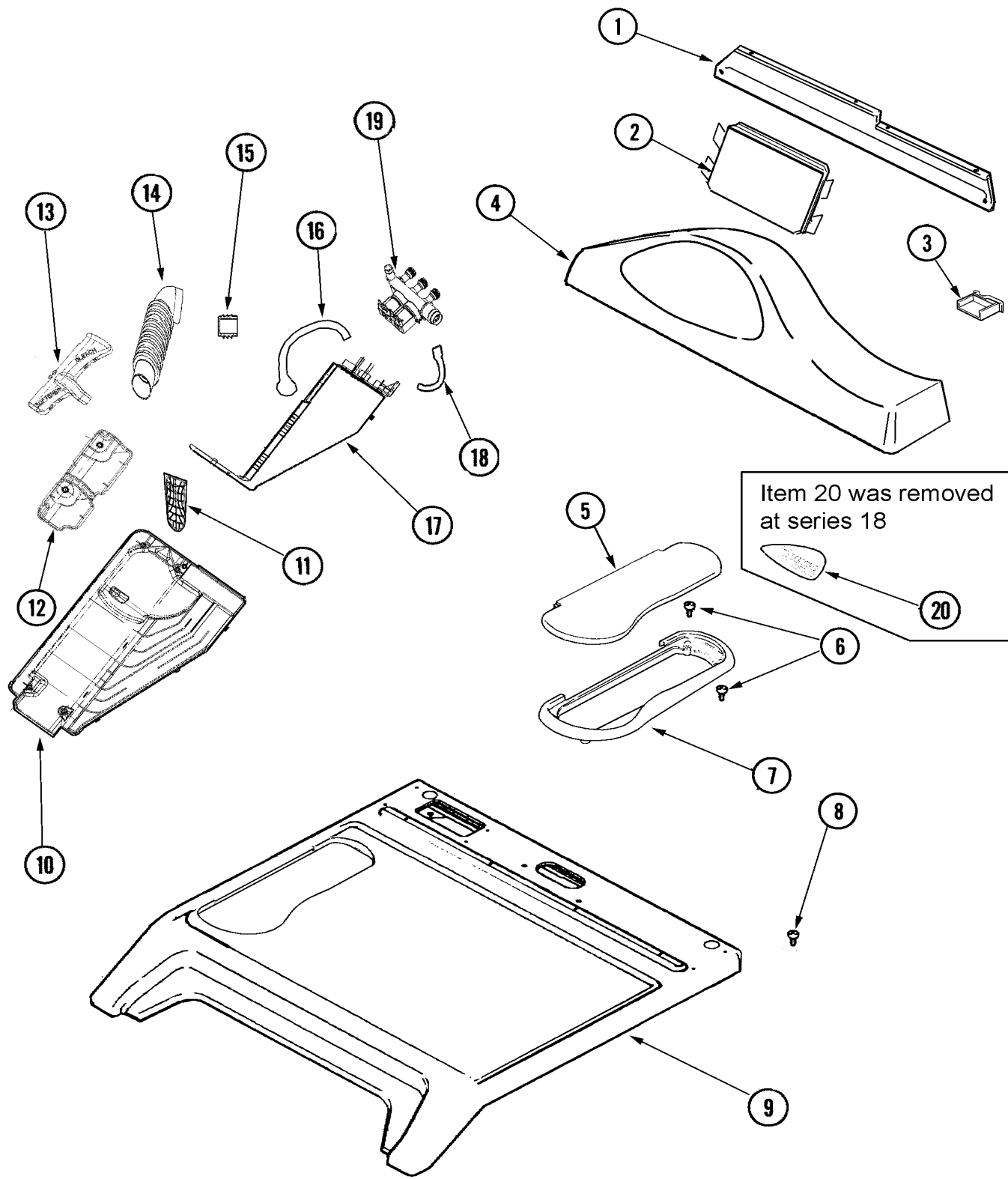

LW11-176

## Section: CONTROL PANEL

No.	Part No.	Description	Series	Qty
1	22003581	BACK, CONSOLE PANEL	10	1
2	22004482	BOARD, CONTROL----SUB	28	1
2	22004316	CONTROL BOARD, LED/NCN	13	1
2	22004446	CONTROL BOARD, AS PACKED SUB	18	1
-	22002061	SCREW	10	4
2	22004488	CONTROL BOARD	29	1
2	22003880	CONTROL BOARD (AS PACK)	10	1
2	22004488	CONTROL BOARD	25	1
3	22003276	COVER, CONSOLE PLUG (WHT)	10	1
4	22004213	FACIA CONSOLE/MEM PAD ASPK WHT	10	1
4	22004438	LED CONSOLE ASSY-WHT - AS PACK	18	1
5	22003274	LID, DISPENSER (WHT)	10	1
6	22003681	SCREW, DISPENSER LID	10	2
7	22003273	BEZEL, DISPENSER (WHT)	10	1
8	912365	SCREW	10	2
9	22004180	COVER, TOP (WHT-AS PK)	10	1
10	22003844	DISPENSER BOTTOM	10	1
11	22003321	GRID, DISPENSER	10	1
12	22003848	SIPHON CUP	10	1
13	22003849	SIPHON CAP	10	1
-	22003627	CLAMP, STEPLESS	10	2
14	22002083	HOSE, INJECTOR	10	1
15	12001929	VALVE SEAL KIT	10	1
-	205161	CLAMP - 15/16"	10	1
16	22003833	HOSE, TUB SHOWER	10	1
17	22003845	DISPENSER COVER (FLUME)	10	1
18	22003832	FILL HOSE, DISPENSER	10	1
-	205161	CLAMP - 15/16"	10	1
19	22003846	DISPENSER VALVE	10	1
-	22002436	SCREW	10	1
20	22003806	MEDALLION, CONSOLE (WHT)	10	1
-	22003854	EMI SUPPRESSION FILTER, 12A	10	1

\*Color Code (-)=Not Shown #=Series, Serial Prefix or Run No., N=Not Available

Section: DOOR & SHROUD

Model: MAH55FLBWW

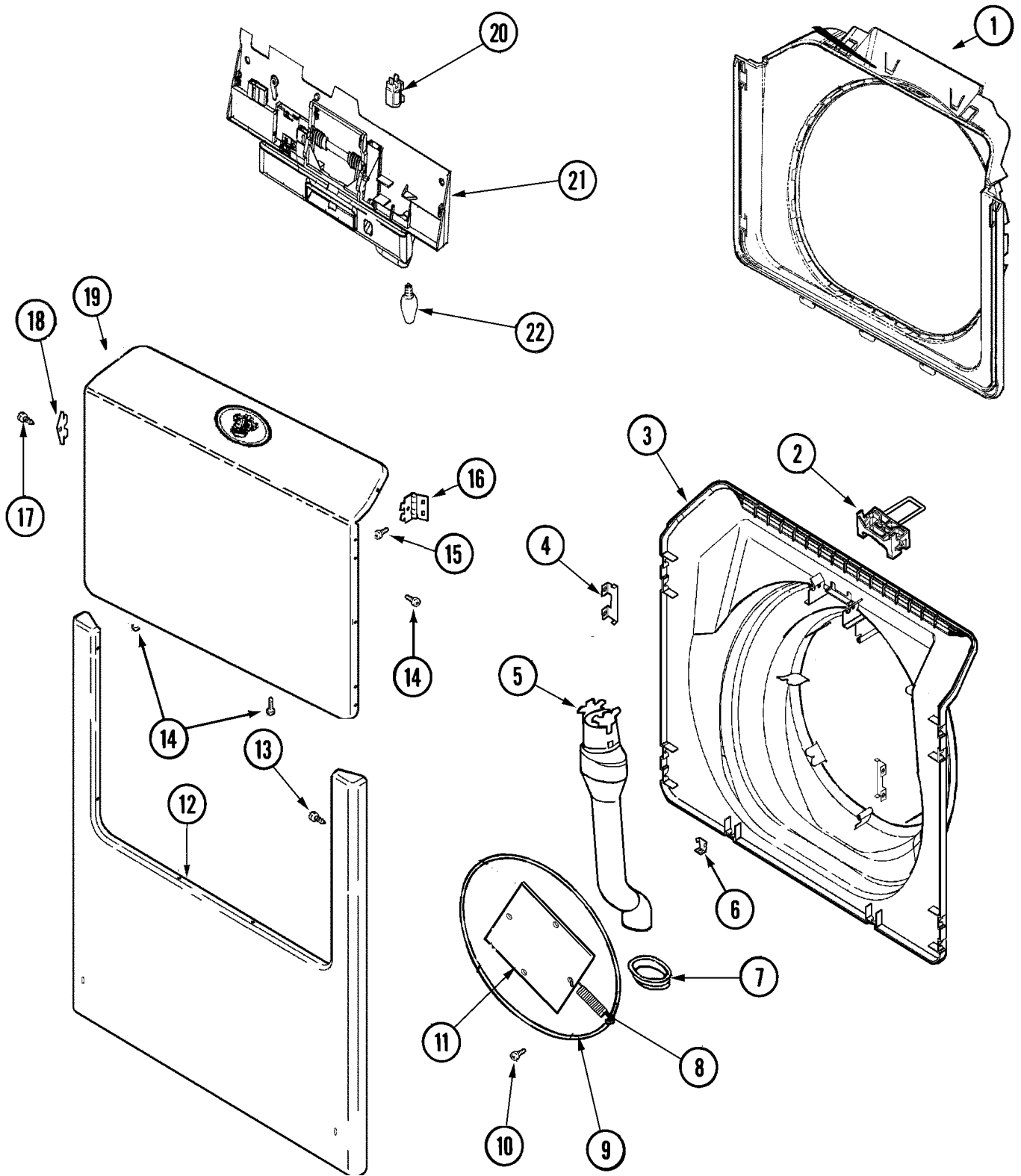

LW18-20

## Section: DOOR & SHROUD

No.	Part No.	Description	Series	Qty
1	N 22003516	SHROUD (WHT)----NA	10	1
2	22003269	DOOR, LOCK HOOP ASSEMBLY	10	1
3	22003275	DOOR, INNER (WHT)	10	1
4	22002038	CLIP, DOOR (DOUBLE)	10	4
5	22003850	VENT TUBE ASSEMBLY	10	1
6	22002039	CLIP, DOOR (SINGLE)	10	2
7	22003075	GROMMET, VENT TUBE	10	1
8	22002356	SPRING, PLATE Note: REMOVED AT SERIES 27 PER ECN EL43377	10	4
9	22002104	WIREFRAME Note: REMOVED AT SERIES 27 PER ECN EL43377	10	1
10	22002007	SCREW Note: REMOVED AT SERIES 27 PER ECN EL43377	10	2
11	22002094	PLATE Note: REMOVED AT SERIES 27 PER ECN EL43377	10	1
12	22002836	PANEL, FRONT (WHT)	10	1
-	22004428	SEAL, EXPORT	10	1
13	22002012	SCREW, HINGE	10	4
14	22002517	SCREW	10	6
15	22002062	SCREW	10	4
16	22002798	HINGE, DOOR	10	2
17	33001787	SCREW, HINGE	10	4
18	33001764	COVER, HINGE HOLE (WHT)	10	2
19	22003242	DOOR, OUTER W/MEDALLION (WHT)	10	1
20	22002433	BULB HOLDER ASSEMBLY	10	1
21	22003593	ASSY., DOOR LATCH	10	1
21	22004435	LATCH, ASSEMBLY DOOR EMZ	18	1
22	22002263	LAMP (10 WATT)	10	1
-	22002305	INSULATION, FRONT PANEL	10	1
-	22002244	CLIP, GROUNDING	10	1

\*Color Code (-)=Not Shown #=Series, Serial Prefix or Run No., N=Not Available

Section: CABINET

Model: MAH55FLBWW

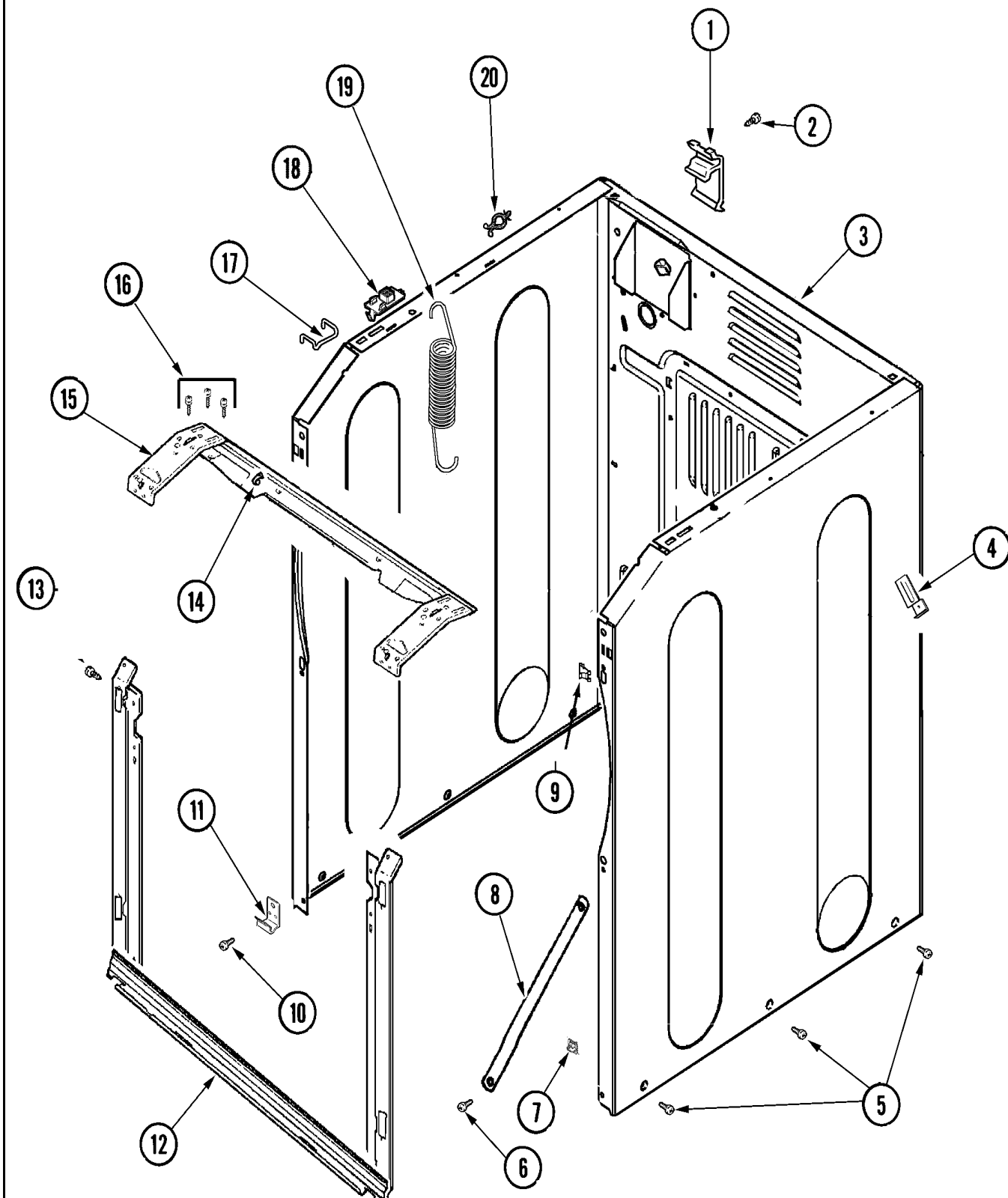

LW12-105

## Section: CABINET

No.	Part No.	Description	Series	Qty
1	22004095	HINGE, PLASTIC	10	2
2	22001995	SCREW	10	2
3	22003639	CABINET ASSY. (WHT AS PK)	10	1
-	22001996	SCREW	10	1
4	33002212	BRACKET, WATER VALVE	10	1
5	213007	SCREW, CABINET	10	6
6	22001995	SCREW	10	4
7	22002013	STOP, SHIPPING	10	2
8	22002259	BRACE, CROSS	10	2
9	22002049	CLIP	10	2
10	22001995	SCREW	10	2
11	22002239	CLIP, LOWER FRONT PANEL	10	2
12	22003652	SHROUD SUPPORT ASSEMBLY	10	1
13	22001995	SCREW	10	4
14	22002014	CLIP	10	1
15	22003637	BRACE ASSEMBLY, TOP CROSS	10	2
16	22001995	SCREW	10	6
17	22002297	SUPPORT, SPRING	10	2
18	22001997	SPACER, TOP COVER	10	2
19	22003254	SPRING, CABINET	10	2
20	22003298	RETAINER, WIRE	10	4

\*Color Code (-)=Not Shown #=Series, Serial Prefix or Run No., N=Not Available

Section: CABINET - REAR

Model: MAH55FLBWW

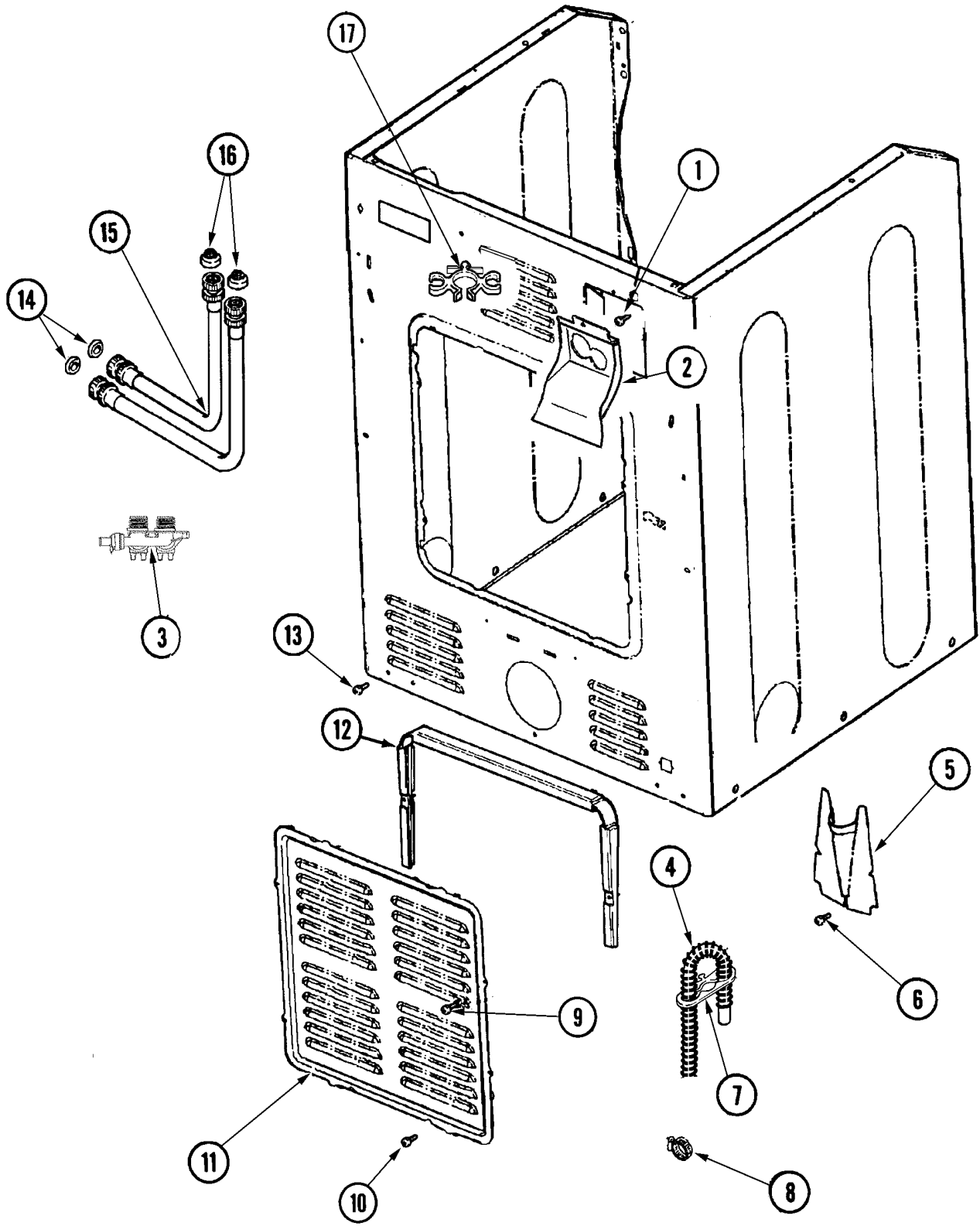

LW12-106



## Section: CABINET - REAR

No.	Part No.	Description	Series	Qty
1	N 33001245	SCREW----NA	10	1
2	22003834	WATER VALVE W' THERMISTOR Note: PILOT ON THIS SERIES ONLY	10	1
-	22003263	SCREW	10	1
3	33002212	BRACKET, WATER VALVE	10	1
4	12001807	KIT NC, DRAIN HOSE REPLACEMENT	10	1
5	22002704	COVER, DRAIN HOSE	10	1
5	35-3401	HOSE, INLET (HOT)	10	1
6	22001995	SCREW	10	1
7	22002892	RETAINER, DRAIN HOSE	10	1
8	22001984	CLAMP, DRAIN HOSE	10	1
9	22002925	SCREW	11	2
9	22002295	SCREW	10	1
10	22001996	SCREW	10	2
11	22002092	PANEL, ACCESS	10	1
11	22004355	REAR ACCESS PANEL	11	1
12	22002022	SPACER, ACCESS PANEL	10	1
13	22001995	SCREW	10	2
14	Y013783	GASKET, INLET HOSE	10	4
15	33-7891	HOSE, 4' INLET	10	1
16	22002229	STRAINER	10	2
17	22002932	CLIP, DRAIN HOSE	10	1

\*Color Code (-)=Not Shown #=Series, Serial Prefix or Run No., N=Not Available

Section: OUTER TUB

Model: MAH55FLBWW

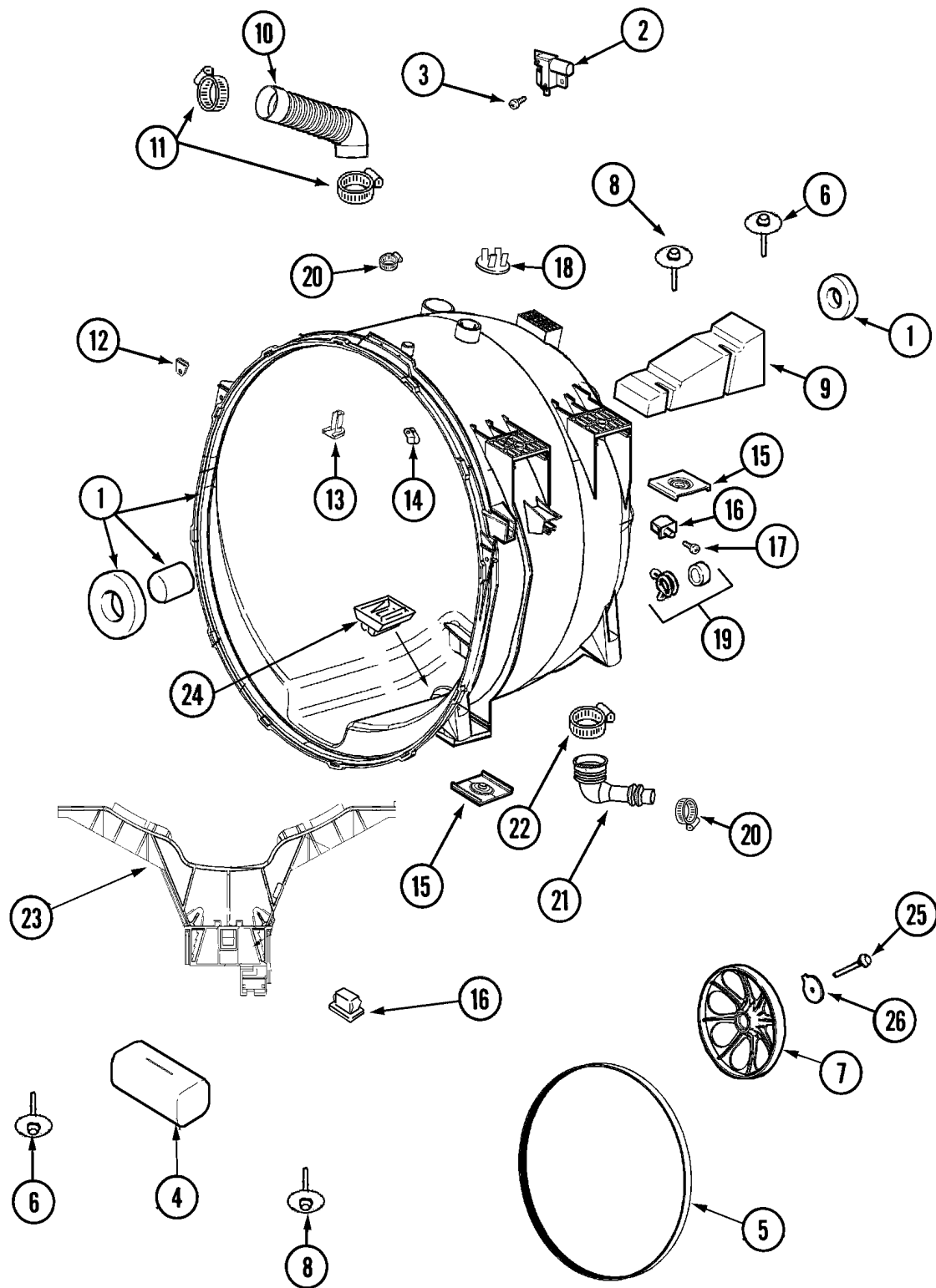

LW13-73

## Section: OUTER TUB

No.	Part No.	Description	Series	Qty
1	22004080	OUTER TUB ASSEMBLY AS-PK KIT Note: (SPACER & BEARINGS AVAILABLE ONLY WITH OUTER TUB ASSY.)	10	1
1	22004465	OUTER TUB ASSY, AS PACK	19	1
2	22003302	SWITCH, INTERNAL UNBALANCE	18	1
-	22004051	UNBALANCE SWITCH SHIELD	18	1
3	22002300	SCREW	10	3
-	22002061	SCREW	18	1
4	22003827	CUSHION	10	1
5	12001435	BELT KIT, DRIVE	10	1
6	33002973	SCREW, #9-15 X 1.00 HX WS	20	2
6	22003828	PLATED BOLT, DOUBLE SEMS SU	11	2
7	22001998	PULLEY, SPINNER	10	1
8	22003828	PLATED BOLT, DOUBLE SEMS SU	11	2
8	33002973	SCREW, #9-15 X 1.00 HX WS	20	2
9	22002102	WEIGHT, COUNTER BALANCE	10	1
10	22002083	HOSE, INJECTOR	10	1
11	22003627	CLAMP, STEPLESS	10	2
12	22002103	CLIP, U	10	2
13	22002959	DEFLECTOR, WATER	10	1
14	22003326	CLIP, HEATER HARNESS TO TUB Note: CLIP, WIRE HARNESS & OUTER TUB	10	3
-	22003326	CLIP, HEATER HARNESS TO TUB	10	1
15	22002065	NUT, COUNTER BALANCE	10	2
16	22002044	SWITCH, TUB DISPLACEMENT	18	1
17	22002061	SCREW	10	1
-	22002061	SCREW Note: SCREW, SADDLE HORN CLIP	10	1
18	22002797	CLIP, HOSE (SADDLE HORN)	10	1
19	22003261	PLUG, OUTER TUB	10	2
20	205161	CLAMP - 15/16" Note: CLAMP - 15/16", TUB TO PUMP	10	1
21	22003262	HOSE, TUB TO PUMP	10	1
22	22002053	CLAMP, SUMP HOSE	10	1
23	22003826	LOWER BRACKET	10	1
-	22003828	PLATED BOLT, DOUBLE SEMS SU	10	2
23	22004472	BRACKET, LOWER	19	1
-	22003263	SCREW Note: SCREW (SUMP CAP)	10	2
24	22003710	SUMP CAP W/ LABYRINTH FEATURE	10	1
25	22002057	SCREW, SPINNER	10	1
26	22002055	WASHER, SPINNER SHAFT	10	1
-	22003936	WASHER (1 1/4")	17	1

\*Color Code (-)=Not Shown #=Series, Serial Prefix or Run No., N=Not Available



## Section: SPINNER ASSEMBLY & OUTER TUB COVER

No.	Part No.	Description	Series	Qty
1	12002022	LIP SEAL KIT	A1	1
2	22003073	CLAMP, HOSE DOUBLE WIRE	10	1
3	22004081	SPINNER SUPPORT ASSY AS-PK KIT	A1	1
-	22002123	TUBE, MOLYKOTE	10	1
-	22004108	O RING	A1	1
4	22002023	WASHER, PLASTIC	10	3
5	22002115	SPINNER ASSY. (W/BALANCE RING) Note: (BALANCE RING NOT AVAILABLE AS A SEPERATE PART)	10	1
6	22002482	WASHER, PROFILE	10	3
7	22002020	WASHER, SPINNER SUPPORT	10	3
8	22002122	NUT, SPINNER ATTACHMENT	10	3
9	22001985	BAFFLE, DRIP (REAR)	10	3
10	22002009	GROMMET, BAFFLE (REAR)	10	3
11	22001999	GROMMET, BAFFLE (FRT)	10	3
12	22002325	SCREW Note: SCREW, BAFFLE (REAR)	10	6
13	22001986	BAFFLE, DRIP (FRONT)	10	3
14	22002059	SCREW Note: SCREW, BAFFLE (FRONT)	10	6
15	22002077	SEAL, TUB COVER	10	1
16	22002050	CLIP, TUB TO COVER	10	13
17	22004264	ASSY., TUB COVER & SEAL	A1	1
-	22003326	CLIP, HEATER HARNESS TO TUB	10	1
-	22004254	COVER, TUB W/SEAL&CAPS ASPK	11	1
-	22003081	PLUG	10	1
18	12001772	KIT, DOOR BOOT W/DRAIN	10	1
19	22002099	SPRING, TUB	10	1
20	22002327	BOOT CABLE CLAMP	10	1
21	22003074	GUARD, HOSE	10	1
22	22003072	CLAMP, HOSE DOUBLE WIRE	10	1
23	22003071	DOOR BOOT DRAIN HOSE Note: HOSE, DOOR BOOT DRAIN	10	1

\*Color Code (-)=Not Shown #=Series, Serial Prefix or Run No., N=Not Available

Section: BASE

Model: MAH55FLBWW

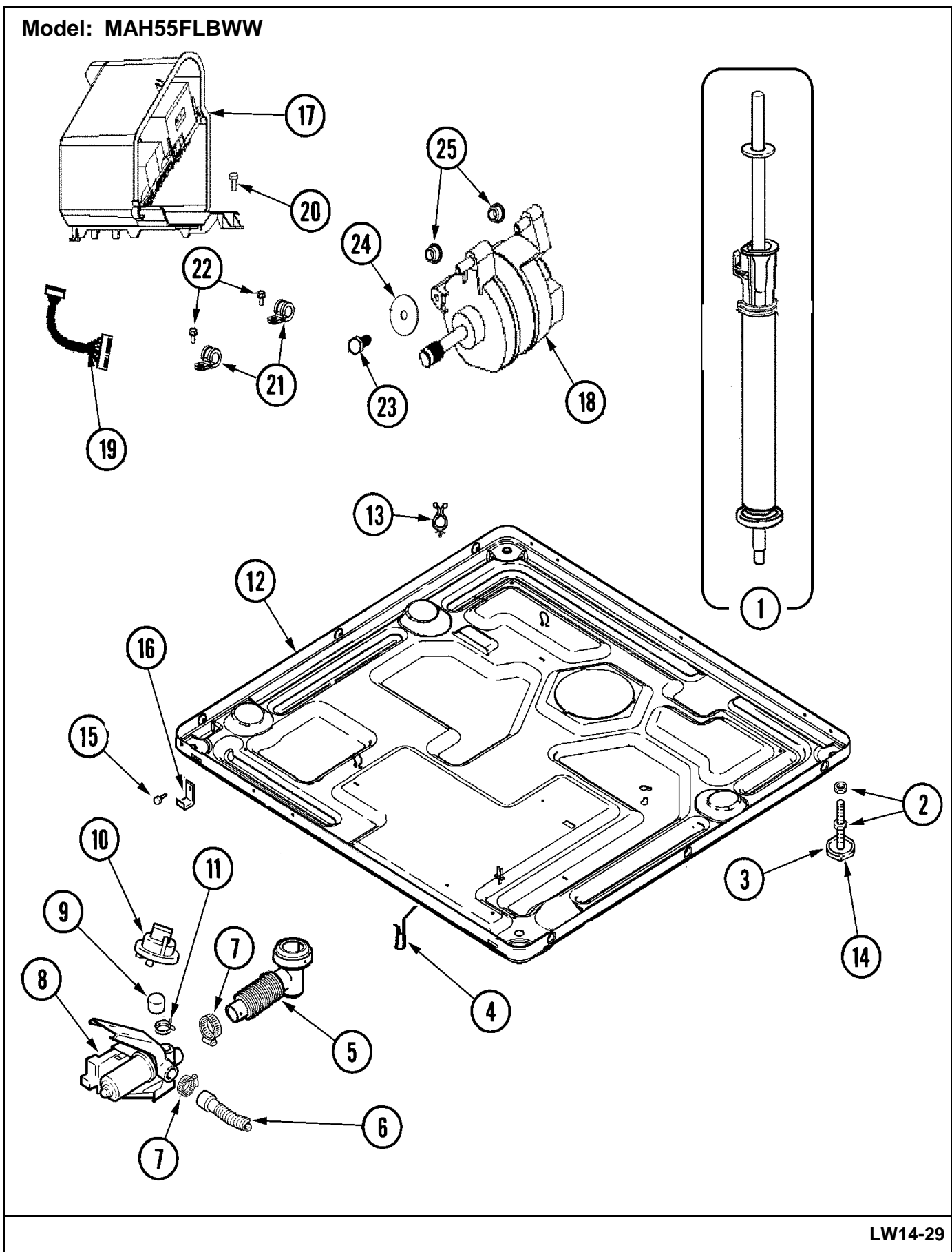

LW14-29

## Section: BASE

No.	Part No.	Description	Series	Qty
1	22001988	STRUT ASSY-REAR	10	1
2	Y052740	NUT	10	4
3	22001915	ADJUSTABLE LEG & NUT	10	4
4	22002244	CLIP, GROUNDING	10	2
5	22003262	HOSE, TUB TO PUMP	10	1
6	12001807	KIT NC, DRAIN HOSE REPLACEMENT	10	1
7	202515	HOSE CLAMP - 1-1/16 INCH	10	2
8	22003244	PUMP	10	1
8	25001012	PUMP ISOLATOR BRACKET Note: NOT SHOWN ON GRAPHICS	10	1
9	22003268	CAP, RUBBER	10	1
10	22004500	SWITCH, PRESSURE-2 LEVEL	25	1
10	22003728	SWITCH, PRESSURE	28	1
- N	22003265	BAG, PLASTIC W/DRAWSTRING	10	1
10	22004500	SWITCH, PRESSURE-2 LEVEL	29	1
10	22003728	SWITCH, PRESSURE	10	1
11	22002853	CLAMP, HOSE	10	1
-	22002014	CLIP	10	1
12	22003605	BASE WELD ASSEMBLY	10	1
13	22003298	RETAINER, WIRE	10	3
14	210684	FOOT, RUBBER	10	4
15	22001995	SCREW	10	2
16	22002239	CLIP, LOWER FRONT PANEL	10	2
17	22004046	CONTROL ASSY., MOTOR	10	1
17	22001995	SCREW	24	2
17	22004473	MOTOR CONTROL ASSEMBLY	22	1
17	22001995	SCREW	22	2
17	22004473	MOTOR CONTROL ASSEMBLY	21	1
17	22001995	SCREW Note: NOT SHOWN ON ART	21	2
17	22004473	MOTOR CONTROL ASSEMBLY	24	1
18	22003856	MOTOR, VARIABLE SPEED	10	1
19	Y2205141	HARNESS, WIRE	24	1
19	Y2205141	HARNESS, WIRE	21	1
19	22004047	HARNESS, MOTOR/MOTOR CONTROL	10	1
20	22002300	SCREW	10	1
21	22004102	P CLIPS	10	2
22	22004047	HARNESS, MOTOR/MOTOR CONTROL	10	2
23	22003686	BOLT, MOTOR	10	1
24	22002320	WASHER, STRUT	10	1
25	22003329	ISOLATOR, MOTOR	10	2

\*Color Code (-)=Not Shown #=Series, Serial Prefix or Run No., N=Not Available

**Section: SUPPLEMENTAL INFORMATION**

No.	Part No.	Description	Series	Qty
1	2205140	HARNESS, WIRE	22	1
1	22004052	HARNESS UPPER SUB ASSY	10	1
1	22004432	HARNESS, UPPER SUB	18	1
1	22004431	HARNESS, MAIN LED Note: SUB AT SERIES 21 TO 2205083	18	1
1	22004499	HARNESS, WIRE	26	1
2	22004047	HARNESS, MOTOR/MOTOR CONTROL	10	1
3	22004146	WIRE HARNESS	10	1
3	22004313	WIRE HARNESS	12	1
4	22002782	PAD, FOAM (SOUND DAMPENER)	10	6
5	22003853	POWER CORD AS WRAPPED	10	1
6	211881	GROMMET, CORD	10	1
7	22003928	VIDEO USER GUIDE / LED	10	1
8	16008373	MANUAL, SERVICE-NO REFUND	10	1
9	22003325	TAG, ENERGY (LED)	10	1
10	2201907	MANUAL, USE & CARE	17	1
10	2206687	MANUAL, USE & CARE LED WASHER	23	1
10	6 2727060	MANUAL, USE & CARE	10	1
11	22003218	LAUNDERING TIPS (TRILINGUAL)	10	1

\*Color Code (-)=Not Shown #=Series, Serial Prefix or Run No., N=Not Available









**Section: WIRE INFORMATION**

No.	Part No.	Description	Series Qty
1	N 15003570	WIRING INFORMATION	15 1

\*Color Code (-)=Not Shown #=Series, Serial Prefix or Run No., N=Not Available

# Section: WIRING INFORMATION

Model: MAH55FLBWW

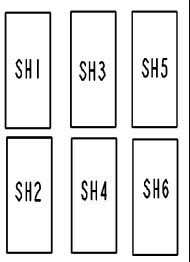

PAGE LAYOUT SEE NOTE 7

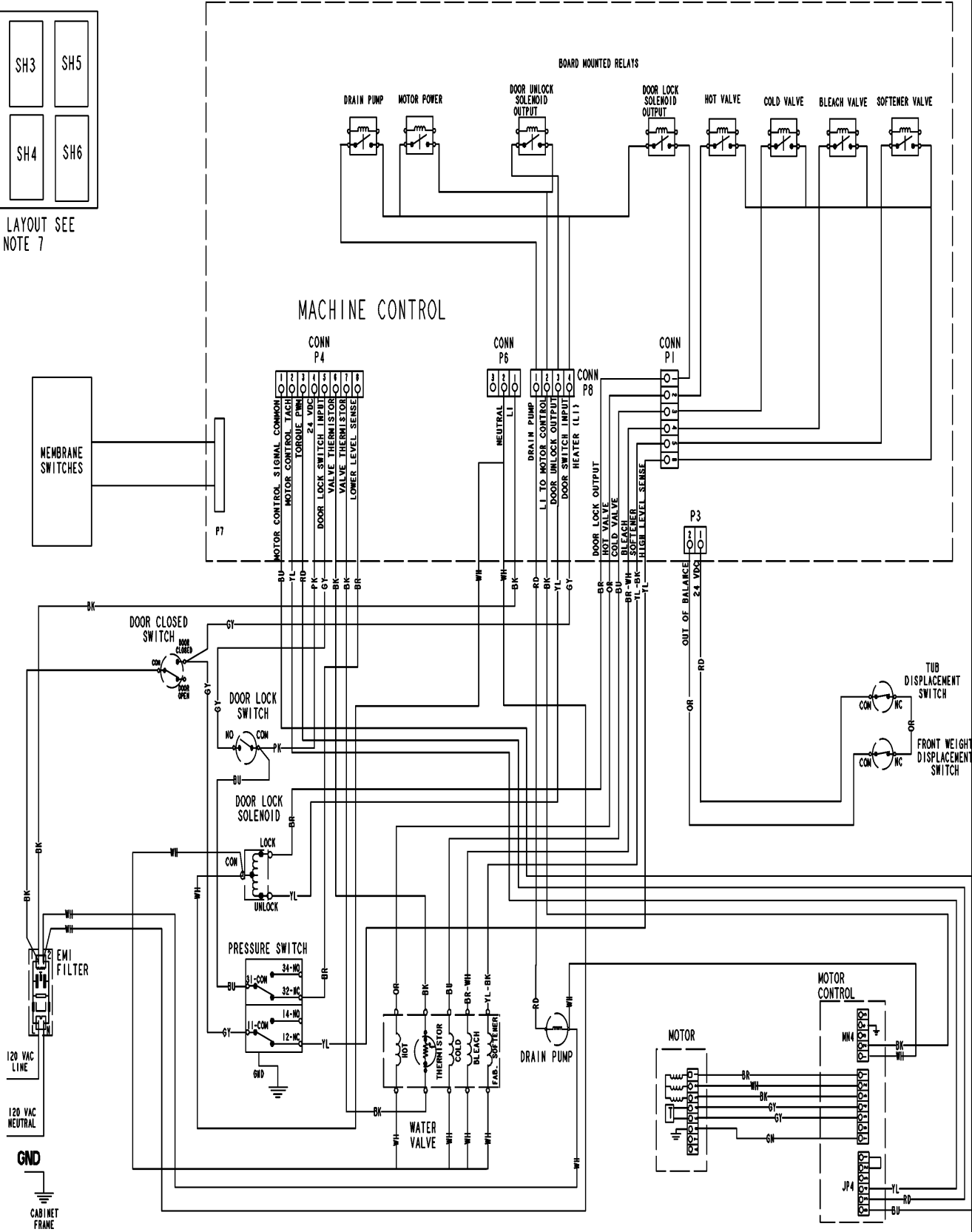

15003674

